

# HISTORIC AMERICAN TIMBER JOINERY

## A Graphic Guide

### III. Sill and Floor Joists

*THIS article is third in a series of six to discuss and illustrate the joints in American traditional timber-framed buildings of the past, showing common examples with variations as well as a few interesting regional deviations. The series was developed under a grant from the National Park Service and the National Center for Preservation Technology and Training. Its contents are solely the responsibility of the author and do not represent the official position of the NPS or the NCPTT. Previous articles, which appeared respectively in TF 55 and 56, covered Tying Joints: Tie below Plate and Tying Joints: Tie at Plate. Future articles in the series will cover Wall Framing, Roof Joinery, and Scarf Joints.*

**J**UST as the plates and tie beams hold together the upper part of the timber frame, the sills tie the posts at the foundation level. Though not subjected to the same stresses as tie beams above, sills keep the bottom of the building from spreading. Many old structures whose sills are decayed are noticeably wider at the bottom.

Sills also distribute column loads over the foundation, act as bond beams to hold together the top of the stonework and stiffen and support walls and the first floor. Sill timbers are typically rectangular in cross-section and laid flat.

**SILL CORNER JOINTS.** The most critical joint, often least documented, is at the corner where the longitudinal (or long wall) sill, the end wall (or gable) sill and the corner post join. In many old structures this joint is badly decayed or the sills have been replaced and a simple half-lap joint substituted.

**Blind mortise and tenon.** Far and away, the most frequent sill corner joint is the blind mortise and tenon (Fig. 1). It combines simplicity with effectiveness. Both the sill and post mortises have relish to prevent horizontal displacement. The relish is usually equal to the tenon thickness, that is, 1 1/2 or 2 in. This design offers a modest amount of weather protection. Even though most American frames are covered by siding, wind-driven rain can penetrate. This joint has its origins in Europe where timber frames are often exposed to the elements. Usually one pin secures the two sills while the post bottom has a stub tenon. If the post has a longer tenon of, say, 3 in. (still without a pin), the sill mortise and tenon will be framed lower to avoid a conflict.

**Through Mortise and Tenon.** Much less common is this through mortise and tenon variety (Fig. 2). It occurs typically where sills are square in cross-section, or rectangular and set on edge, as the through joint increases tensile capacity for a narrow sill. Unfortunately, weather resistance is diminished compared with the blind joint, and the mortises are more likely to split open and the relish to fail.

**Sloped Tabled Corner Lap.** Only one example of this joint has so far been found (Fig. 3), in a barn in St. Johnsville, New York. It appears to be of Germanic design. The dovetail-like lap prevents lateral displacement, but, unlike the mortise and tenon type, it must be sandwiched between the post and foundation to be effective. Otherwise, twisting from seasoning or subsiding of the foundation can render it ineffective.

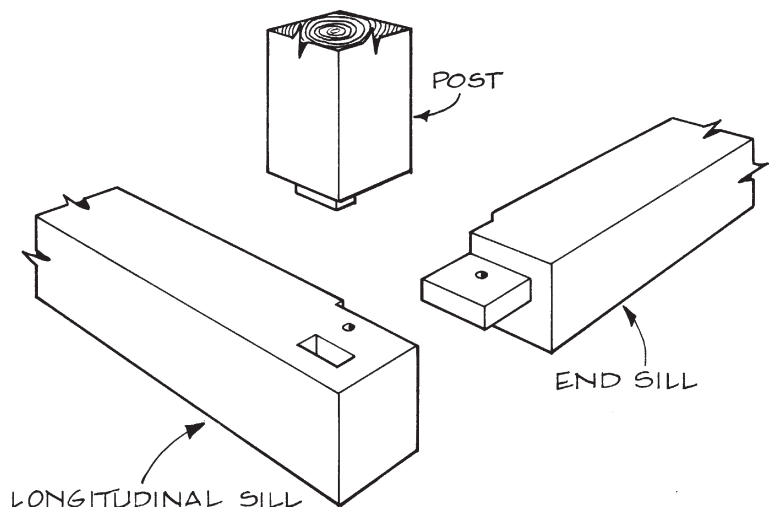

*Figs. 1 and 2. Blind (above) and through (below) mortise and tenon joints, both sized according to square rule layout.*

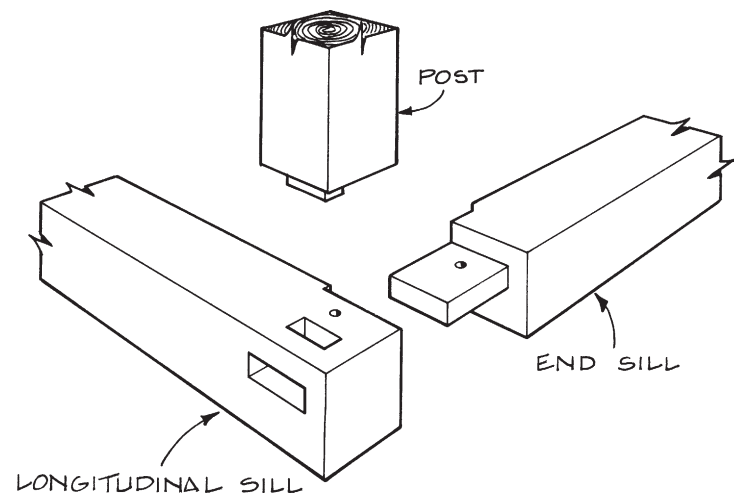

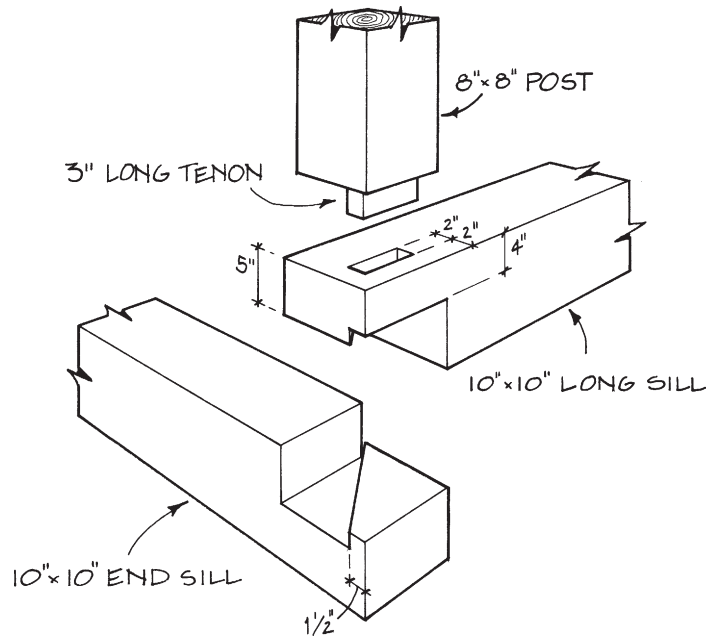

Fig. 3. Unique sloped and tabled corner lap, St. Johnsville, N.Y.

**INTERMEDIATE SILL GIRDER JOINTS.** These are connections where interior sill girders meet either longitudinal or end wall sills. They often have posts bearing on them.

**Blind Mortise and Tenon.** Again this joint is the most common type (Fig. 4). Because there is no question of relish as at the corner, the tenons can be wider and typically are secured with two pins. This joint is moderately weather-resistant.

**Inverted Lapped Full Dovetail.** Rarely, the bottom of the end wall sill receives the lap dovetail (Fig. 5). It is secured by being sandwiched between the foundation and the sill.

**Lapped Half-Dovetail.** This simple joint (Fig. 6) is somewhat common in Dutch barns where the interior longitudinal sills for the posts join the end wall sills. The purlin posts are tenoned into the lap dovetail.

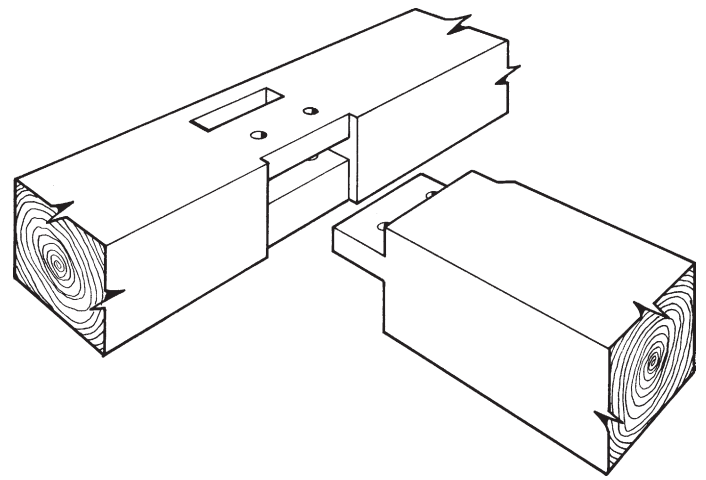
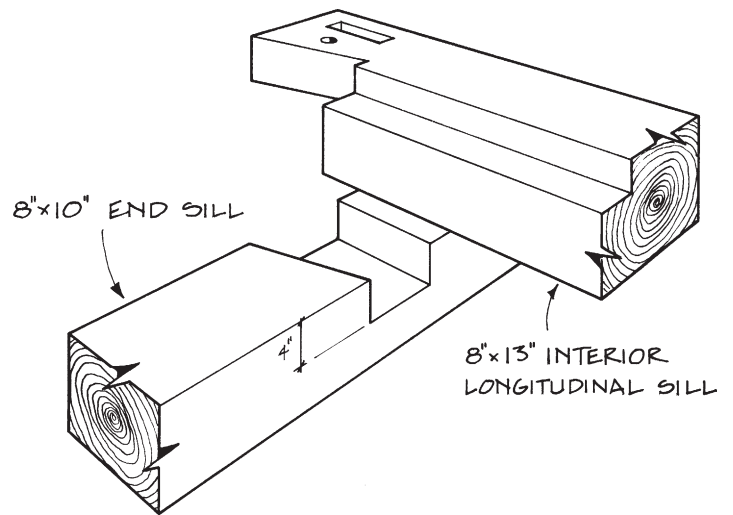

Fig. 4. Blind tenoned girder joint.



Drawings Jack A. Sobon

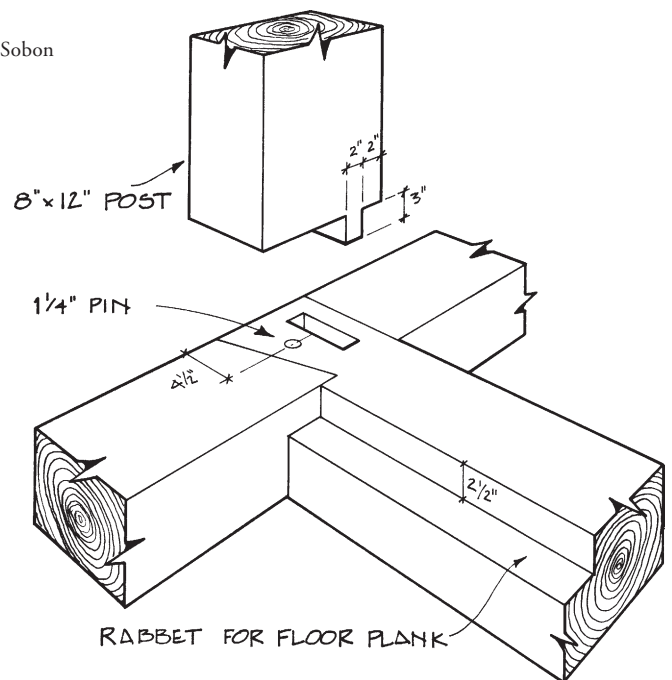
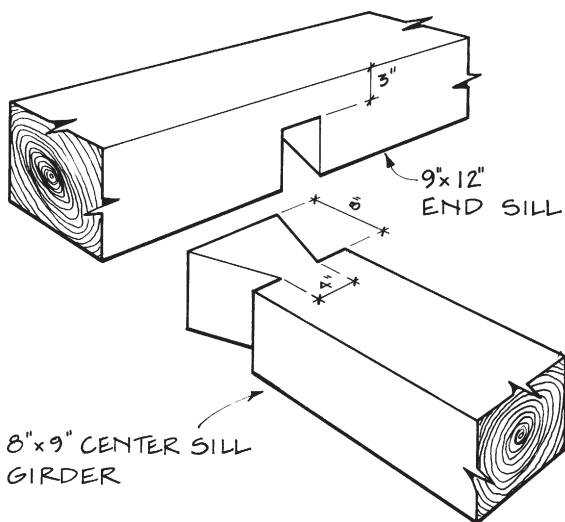

Fig. 5. Inverted lapped dovetail in Dutch barn moved from Guilderland to North Tarrytown, N.Y. The 47-ft. girder supports a 3-in. plank threshing floor and is well protected from weather. Assembled, the undersurface of the girder lies 2 in. below the undersurface of the sill.

Fig. 6. Views of lapped half-dovetail girder joint in a pre-1820 scribe rule Dutch barn moved from Fort Plain to Altamont, N.Y. The interior sill is rabbetted for the 2 1/2-in. splined plank threshing floor.

**Plank Sill.** This unusual sill system has been seen on at least two scribe-rule-framed 18th-century New York Dutch houses, one standing in Stuyvesant (Fig. 7) and the other (now dismantled) formerly in Cohoes. Both houses, built with unfired brick infill between the posts, measure about 18 ft. wide, with full-span floor joists. Because of their long span and wide spacing (4-5 ft.), the joists are 12 in. deep. But a corresponding 12-in. sill is both impractical and unnecessary. With the plank sill system, the joists are set into the stone or brick foundation and a 2x6 plank is notched and nailed to secure them. The plank is through-mortised for the posts, and the mortise extends an inch into the joist as well. This design saved on material and joinery, and was probably also a time-saver during the scribe layout process. It has proved itself over time.

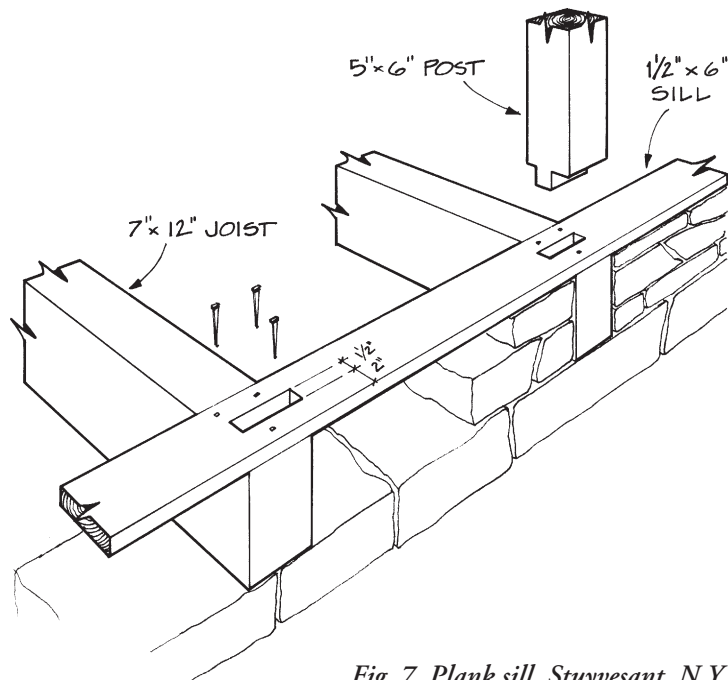

Fig. 7. Plank sill, Stuyvesant, N.Y.

**FLOOR JOISTS AND GIRDER JOINTS.** In the days when most timber was hewn, considerable time could be saved by hewing some members only on faces that had to be flat to receive sheathing. Thus floor joists, especially ground floor and barn joists, were often hewn only on top. At the joint they were shaped to a rectangular cog (Fig. 8).

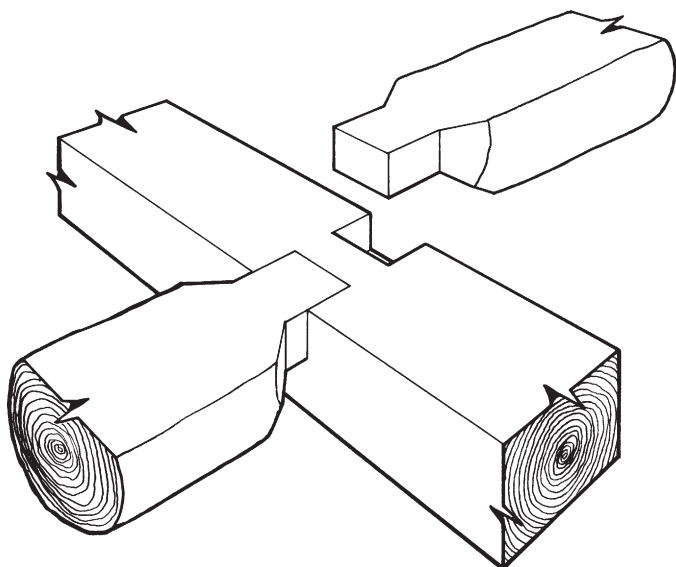

Fig. 8. Flattened log joists.

**Butt Cog Joint.** The simplest joint to craft and insert, and consequently the most common, is the simple drop-in pocket or butt cog (Fig. 9). The full depth of the joist may be notched into the girder, or, more commonly, the joist is reduced in depth at the joint so as not to cut too much out of the girder. When the joist end is reduced in this way, the stiffness or bending strength of the joist is not affected, but its shear strength is diminished at the joint.

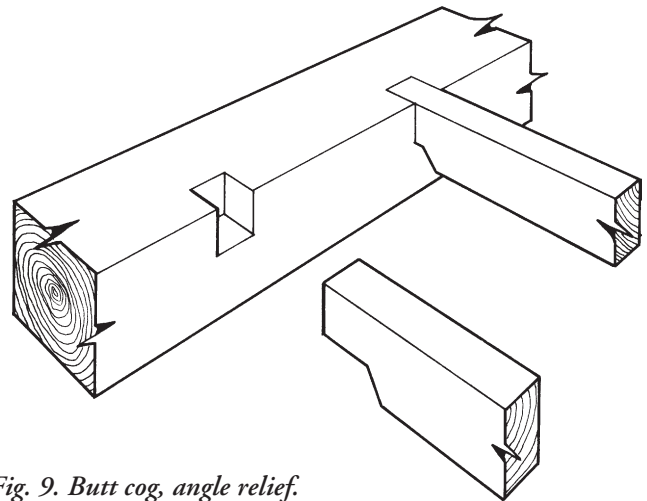

Fig. 9. Butt cog, angle relief.

To avoid concentrating the shear stress at the notch, builders removed additional wood with an axe or adze, on an angle as shown. In a few frames, the joists were reduced in a graceful curve using the adze (Fig. 10).

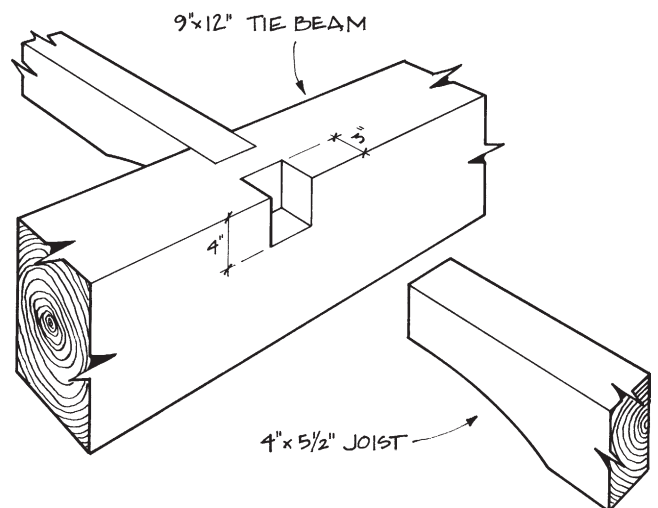

Fig. 10. Butt cog, curved relief.

If the bottoms of joists were to receive lath and plaster, then it was more convenient to use a squared notch at the girder. If the girder was also to be covered with lath and plaster, then the joist was typically notched to half its depth (Fig. 11). The square notch is considerably weaker than the angled or curved type and many old frames exhibit cracks or breaks at the notches.

The popularity of the drop-in joist pocket was in large part due to its convenience during assembly. Drop-in joists are easily inserted from above after the girders or tie beams are in place.

In square rule structures, an additional gain was often cut in the girder below the notch, to size the girder to a consistent width so that all the joists could be cut to one length. The gain was usually a half-inch or less in depth so as not to unduly weaken the girder.

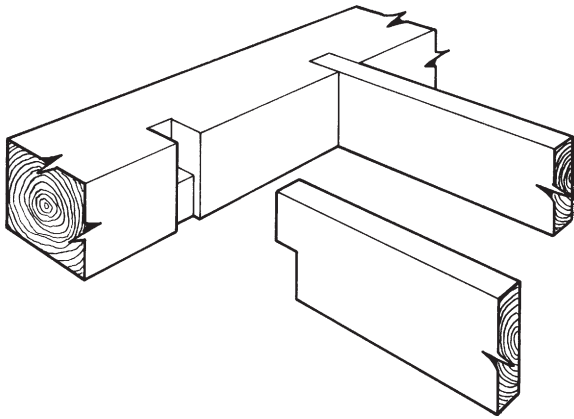

Fig. 11. Narrow full-depth joists with lower sizing housing.

**T**YING JOISTS. Floor frames other than in the smallest buildings required one or two joists in each bay as tying joists to keep the girders or tie beams from spreading. Were they to spread, the cogged joists could withdraw and allow the floor to collapse. The most common tying joint was a half dovetail (Fig. 12).

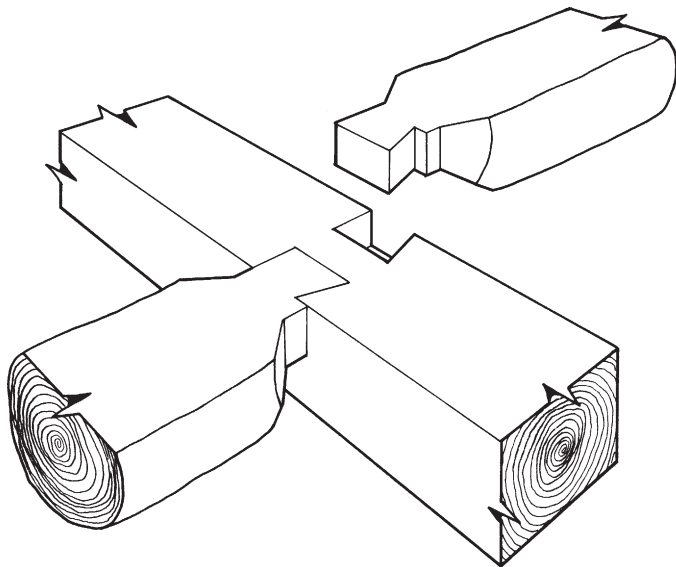

Fig. 12. Half-dovetail butt-cogged flattened log joists.

A variation was to bore a pin hole at the edge of a joist tenon after the joist was in place and drive a squarish pin that both wedged the joist tight against the opposite side and acted as a cog to prevent withdrawal (Fig. 13). On larger framing, the technique could be used on both sides. In framing where the top surface of the joist was elevated above the girder, a lap dovetail could be used (Fig. 14). If the joists were permitted to extend past the girder, the through lap (Fig. 15) was effective. Both of these joints can be found in the side-aisle lofts of Dutch barns.

*Figs. 13-15. At top right (Fig. 13), butt-cogged tying floor joists with cogged pin, Cheshire, Mass., 1791. At middle right (Fig. 14), lapped half-dovetail on side aisle loft joist in a 1680s Dutch barn moved from Saratoga, N.Y., to Hancock, Mass., and since lost to fire. The opposite ends of these joists were vertically tenoned to wall posts. At bottom right (Fig. 15), through laps in side aisle loft joists of a Dutch barn in Westerlo, N.Y. (also lost to fire). The through lap, if simple, is quite effective as a tying joint.*

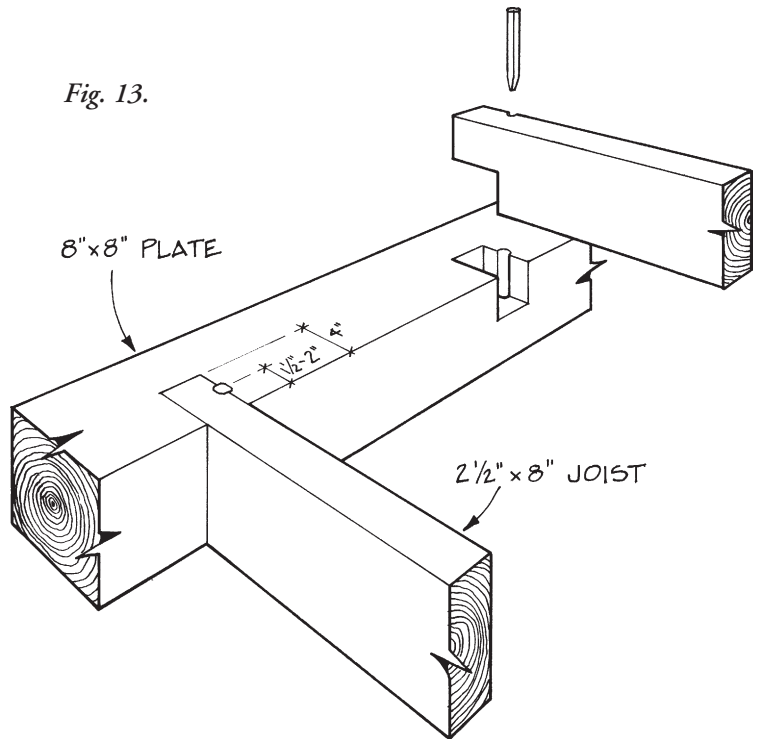

Fig. 13.

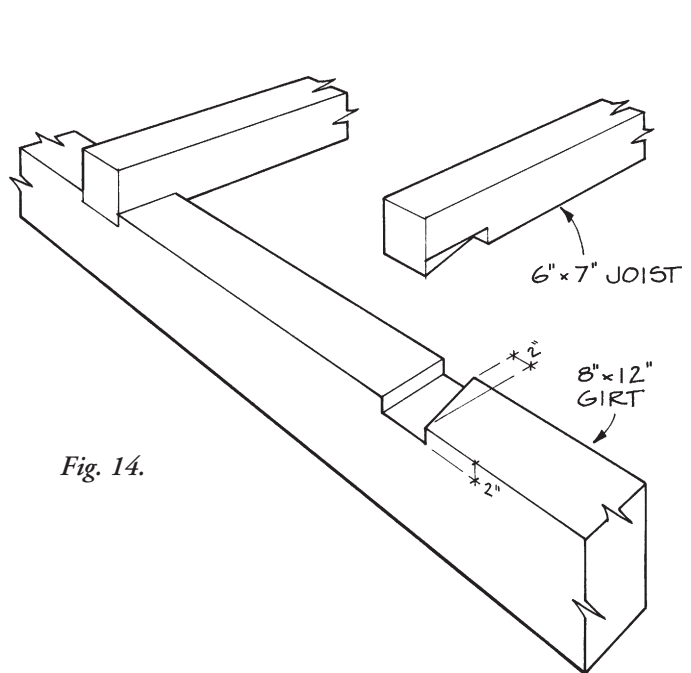

Fig. 14.

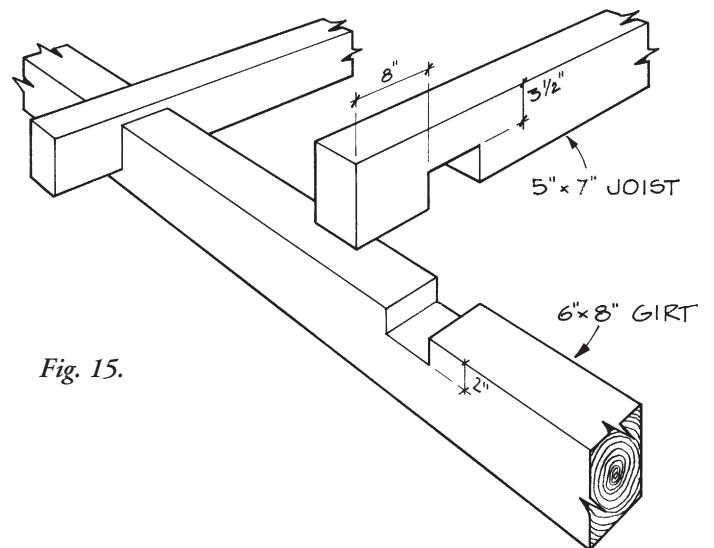

Fig. 15.

**Strengthened Halving.** This variation of the half-lap joint (Fig. 16) is configured to increase capacity for both members by adding bearing surfaces. The lower supporting beam has less material removed compared to a half-lap. The side housings provide better support for the upper girder and lessen shear problems. Examples are found in the attic floor of houses where a central spine beam runs the length of the house, lapping over the tie beams and carrying joists from both sides.

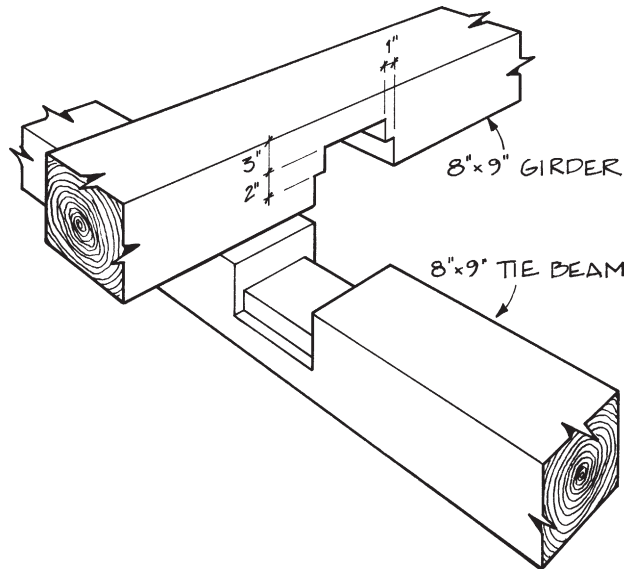

Fig. 16. Strengthened halving found in the attic floor of the 1783 Quaker Meeting House, Adams, Massachusetts. The 8x9 girder ran longitudinally and carried floor joists on both sides.

**TENONED JOISTS.** The tenoned joint's structural advantage for connecting floor joists to a carrying timber is that in cutting the mortise, little or no wood is removed from the top or bottom surfaces of the carrying beam. Since these surfaces are under the greatest stress (compression in the top and tension in the bottom), a beam mortised in its side retains nearly all of its original strength. By contrast, a beam with a butt cog joint cut into each top edge loses 15 to 40 percent of its original strength. Another advantage is that by adding a pin, a tenoned joist becomes a tying joist. (However, a pin hole bored right through a beam reduces its strength. A tight-fitting pin may effectively replace the missing compression wood on top, but the pin cannot replace the tension wood on the bottom.) There is also a disadvantage to tenoned joists: they must be inserted from the side rather than the top. Thus joists are inserted in sets as each bent reaches vertical, or in the case of tie-at-plate examples, as each tie beam is set. Assembly requires careful work with many hands or temporary support structures. Alternately, joists may be tenoned at one end and merely seated on top of a beam at the other as in several 17th-century Massachusetts Bay houses. The simplest form of tenoned joist has the tenon bearing all the load (Fig. 17). The joint is simple to cut and removes a minimum of wood from the summer beam. It is common where closely spaced joists support a plaster ceiling and the joists and summer beam are the same depth. But the tenon is weak in shear.

**Housed mortise and tenon.** A vast improvement in structural performance results from housing the entire joist end into the beam (Fig. 18). The shear problem is eliminated. However, the beam must be sufficiently deeper than the joist. This joint is more often seen on large joists spaced far apart and on headers. Fig. 19 shows a variation housed only below the tenon. This retains slightly more compression wood on the top of the beam while not reducing the shear capacity of the joist.

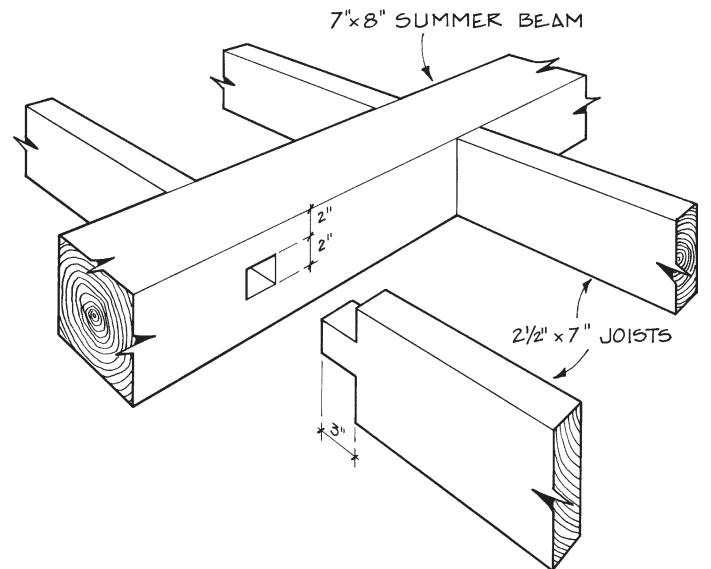

Fig. 17. Simple tenoned joists supported the second floor of a 1791 Cape-style house in Cheshire, Massachusetts.

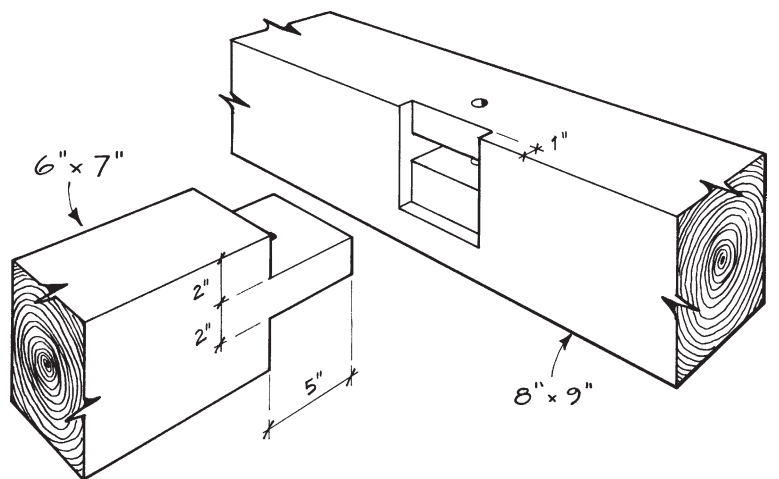

Fig. 18. Heavy aisle loft joist in a pre-1820 Dutch barn in Root, N.Y., part of a set spaced 5 ft. on center with their outboard ends tenoned to posts.

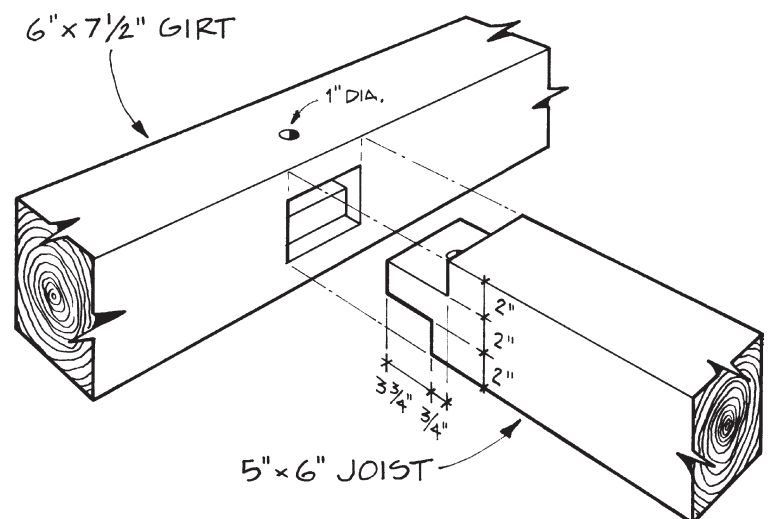

Fig. 19. Aisle loft joist in a Dutch barn, Warnerville, N.Y.

**Strengthened Tenons.** The ultimate tenoned joist has a sloped shoulder above the tenon (Fig. 20) that brings into bearing the entire depth of the joist while keeping intact the vital compression wood of the carrying beam. In 18th- and 19th-century builder's books it is the floor joint of choice. In ideal form, the underside of the tenon is continuous with the joist (and thus properly termed a soffit tenon, Fig. 20) and the mortise in the carrying timber is centered in the side of the beam.

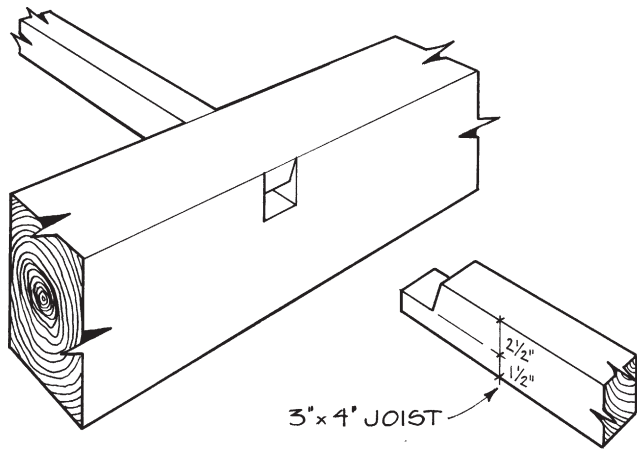

Fig. 20. Typical strengthened tenon, here without pin.

Historically, some authorities (e.g., Joseph Moxon in *Mechanick Exercises*, 1703) called the upper sloping shoulder a tusk; others (James Newlands, *The Carpenter's Assistant*, ca. 1854) reserved that term for an additional bearing shoulder cut beneath the tenon when the joists are too deep for soffit tenoning. In our day, Cecil Hewett (*English Historic Carpentry*, 1980) referred to the upper sloped shoulder as a diminished haunch and the lower square one as a housed soffit shoulder.

Occasionally the lower shoulder too was angled (Figs. 21 and 22) to form what Hewett called a spurred shoulder.

**Other tenon forms.** Any joist tenon can become a through mortise and tenon with wedges to increase tensile capacity (Fig. 23). Especially deep members could have paired tenons (Fig. 24, overleaf).

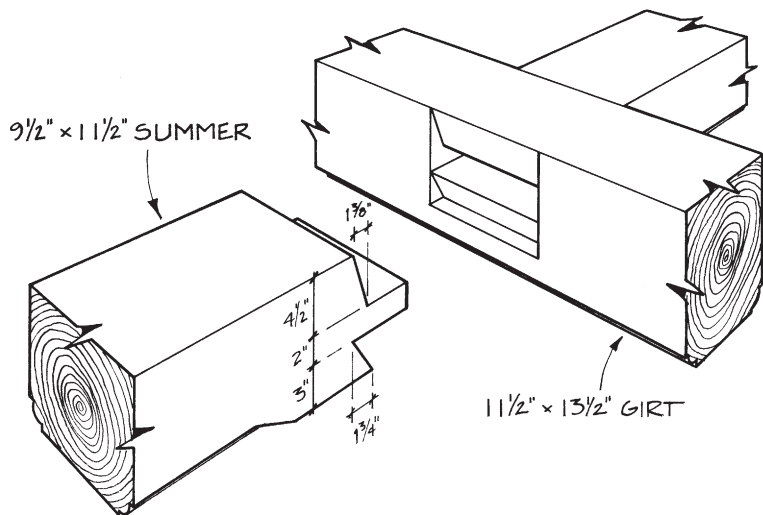

Fig. 21. Summer beam to girt connection in the 1665 Gedney House, Salem, Massachusetts. Both members have molded chamfers.

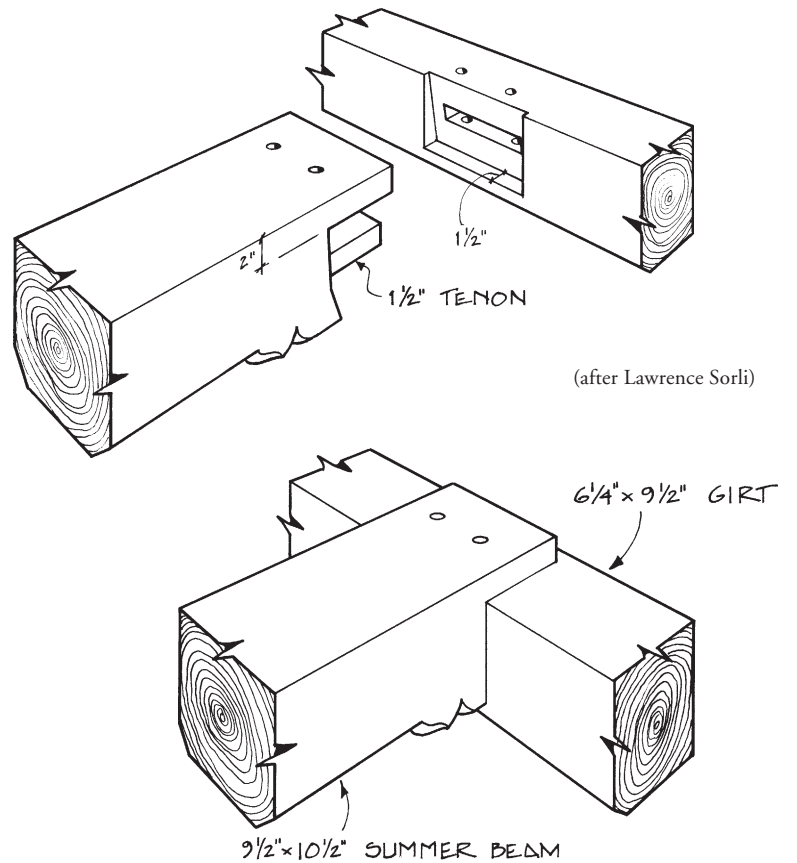

Fig. 22. Equal-depth summer beam and girt in the 1637 Fairbanks House, Dedham, Massachusetts. The summer is raised and lapped 2 in. over the girt to gain needed support at the bottom of the joint. Lack of congruency between housing and tenon shoulders is unexplained.

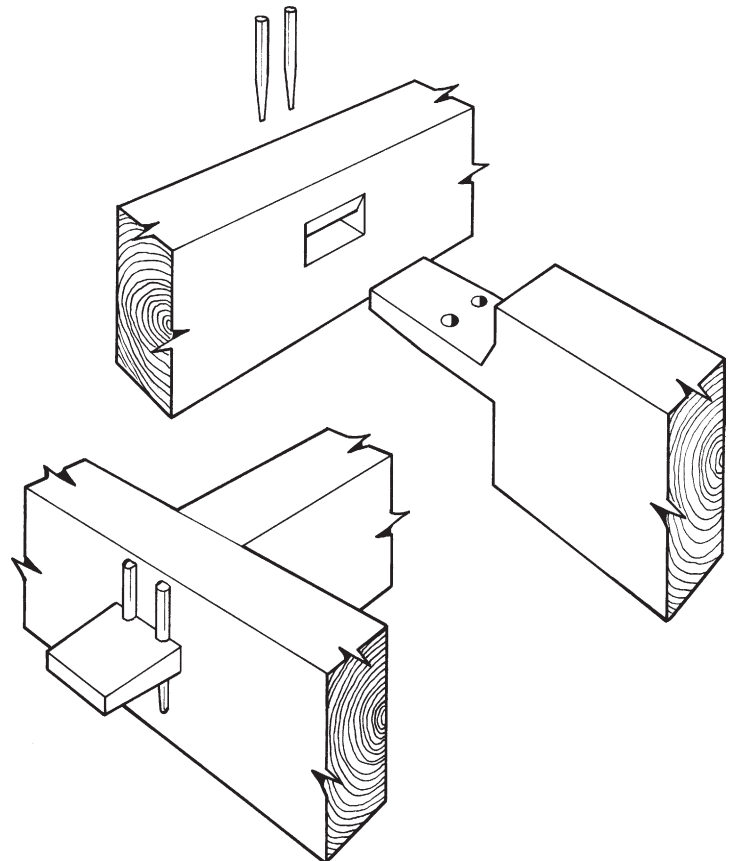

Fig. 23. Through tenon with outside wedges (pins flattened on a taper) in the attic floor of the Presbytere (1847), New Orleans.

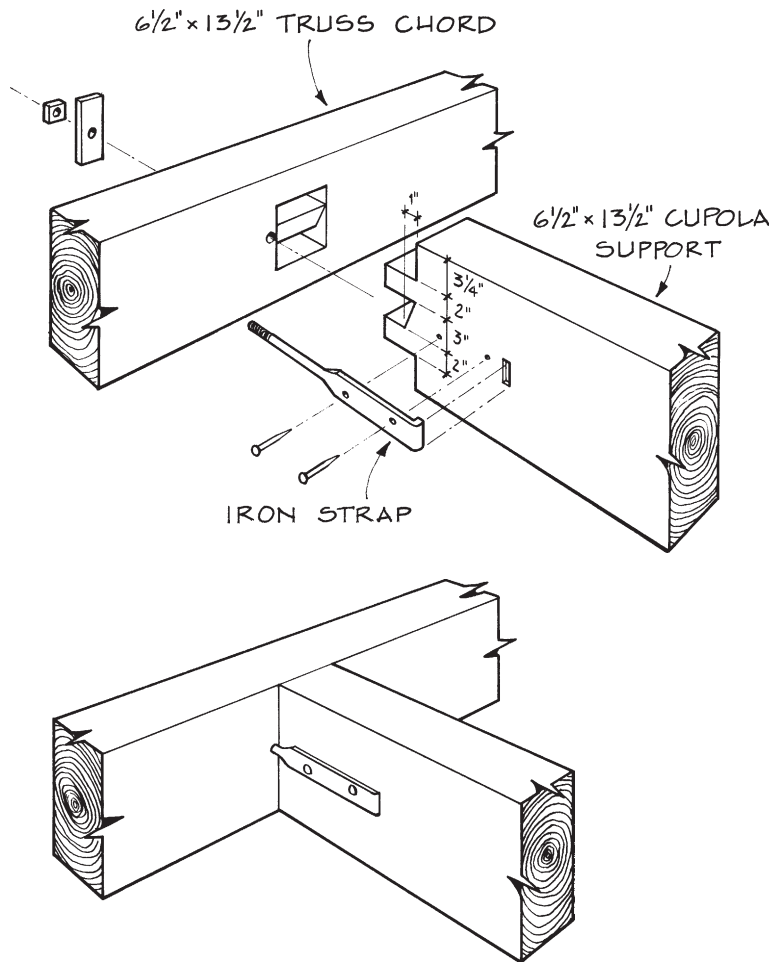

Fig. 24. Paired tenons, one strengthened, carry the ends of beams supporting cupola posts in the roof frame of the Cabildo, the original Spanish city hall in New Orleans (1796, 1849, 1992; see TF 21 and 24). A forged iron strap prevents spreading.

mortises substantially reduce the section of the tie beam. The depth of these mortises must be kept to a minimum.

**The Horizontal Chase Mortise.** In this variation, also called a pulley mortise, a continuous slot connects two or three joist mortises (Fig. 28). Thus multiple joists are maneuvered into place in the same slot.

With all these post-raising insertion types, the spacing of the tie beams, which are long and somewhat flexible, would be secured by at least one tying member near mid-span to prevent spreading of the beams and collapse of the ceiling. The lath would secure the spacing of the joists. Since the horizontal chase mortise does not remove wood from the bottom surface of the tie beam, it is the best solution structurally. However, it is more time consuming to craft than the first three.

—JACK A. SOBON

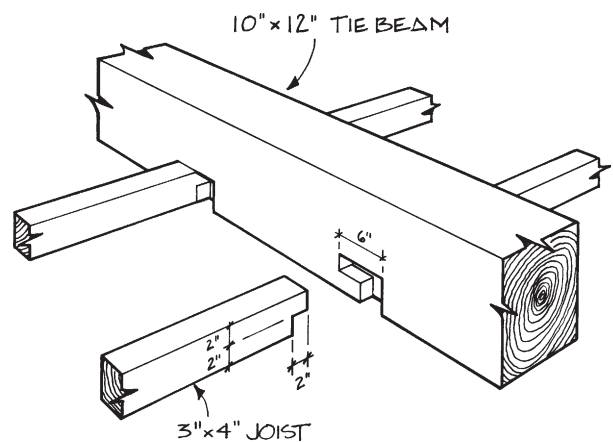

Fig. 25. An L-mortise in the 1829 Newbury, Vermont, Methodist Church. The building measures 45x60 with the ceiling joists spanning about 12 ft. and spaced at 30 in. on center.

**SPECIAL MORTISES FOR CEILING JOISTS.** In larger structures with trussed roofs, such as meeting houses, it was necessary to provide ceiling joists between the tie beams of the trusses. Builders preferred to keep the ceiling joists flush with the bottom of the tie beams so that an uninterrupted plaster ceiling could result. Tie beams are typically deep in section (10-12 in.), while ceiling joists might only be 4 in. deep. Inserting 20 or more tenoned joists between tie beams as the latter are placed would be daunting. Builders used at least four different methods to insert tenoned joists between the tie beams after the trusses were in place.

**The L-Mortise.** This mortise allows the tenon to be lifted up and over (Fig. 25). Only one end of the joist has to be accommodated thus since the tenon on the other end of the joist can be inserted first (at a small angle to the horizontal) into a standard mortise. Though the L-mortises are shallow, they still cut into the bottom surface of the beam. Typically, only one side of each tie beam has these mortises.

**The Short Joist.** A joist with a shorter shoulder to shoulder length than the spacing between the tie beams can be inserted into one mortise an extra 2 or 3 in. deep, then swung into place and slid back until it bears an equal amount at each end (Fig. 26). Of course, the joist needs to be secured from future movement. Its main disadvantage is potential shearing of the tenon.

**The Vertical Chase Mortise.** One end is again inserted first, and the other swung down from above in a chase mortise (Fig. 27). Inserting joists from above is perhaps more convenient, but these

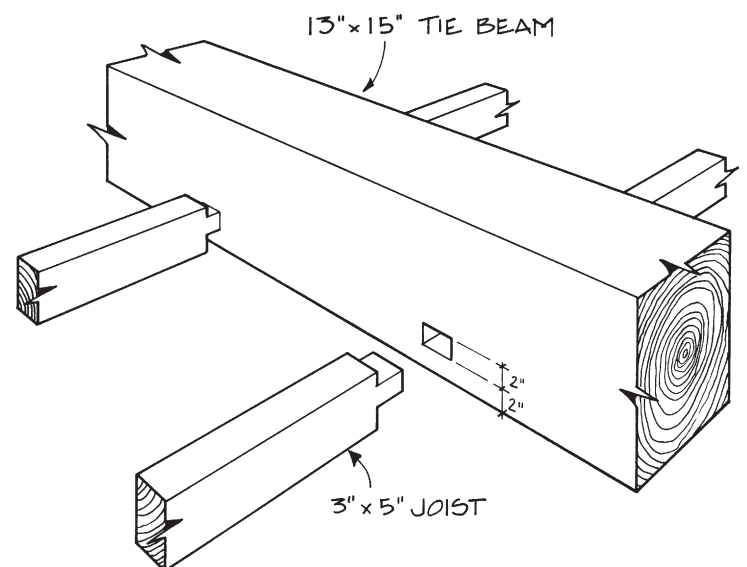

Fig. 26. Beech ceiling joists with shortened shoulders are secured from movement by a single cut nail in the Second Congregational Church, Newport, New Hampshire (1823).

Fig. 27 (right). Board ceiling joists tenoned at one end and notched at the other drop into vertical chase mortises on the tie beams of the 1815 Methodist Church at Chenango Forks, New York (now dismantled). The bearing for the joist in the tie beam is only an inch deep. Close truss spacing of about 8 ft. permits the use of light boards. Similar joinery is found on an 1840 church in Brimfield, Massachusetts.

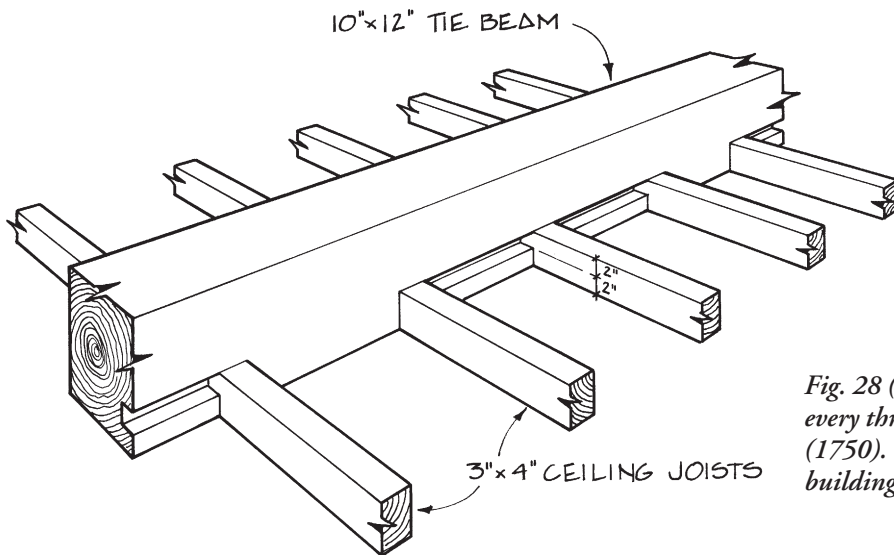
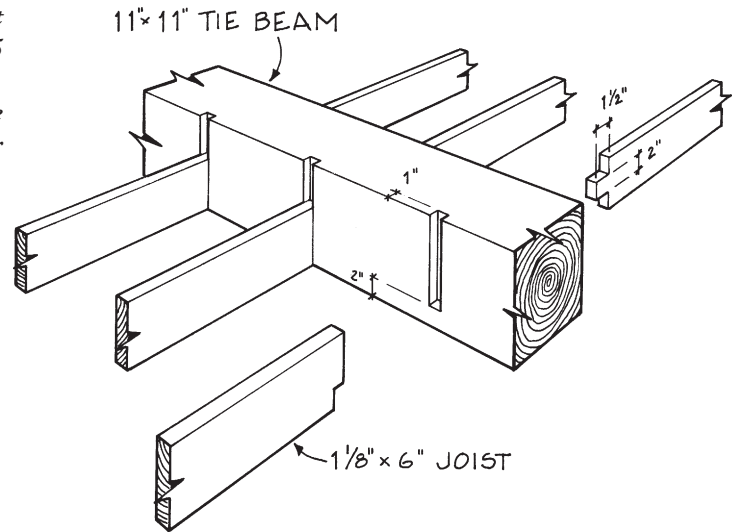

Fig. 28 (left). Long pulley (chase) mortises were cut in the tie beams for every three ceiling joists in the Hatfield, Massachusetts, Meeting House (1750). The opposite side of the ties had simple 2x3 mortises. This building was destroyed while being rolled to a new site in 1979.



Jack A. Sobon

The typical blind sill corner joints on this house frame in Charlemont, Massachusetts, give little clue to their inner mortise and tenon configuration. The first joist to the rear, hewn flat only where necessary, joins the sill in a butt cog. Timber sills and girders, historically a natural part of the timber frame, have virtually disappeared from modern American work.