

HISTORIC AMERICAN TIMBER JOINERY

A Graphic Guide

II. Tying Joints: Tie at Plate

THIS article is second in a series of six to discuss and illustrate the joints in American traditional timber-framed buildings of the past, showing common examples with variations as well as a few interesting regional deviations. The series was developed under a grant from the National Park Service and the National Center for Preservation Technology and Training. Its contents are solely the responsibility of the author and do not represent the official position of the NPS or the NCPTT. The first article, which appeared in TF 55, covered Tying Joints: Tie below Plate. Future articles in the series will cover Sill and Floor Joints, Wall Framing, Roof Joinery, and Scarf Joints.

THE tie-at-plate category encompasses the most complex and varied of timber joints, including not only wall, roof and cornice work, but also attic floor framing. Builders often used components to double advantage. Floor joists, for example, could become additional tie beams. Some tying joints could be considered “secret” joints since their configuration and method of assembly are a mystery until they are disassembled. In houses they are often difficult to document *in situ* because of their dusty, cluttered location in the attic. Many of the examples included here were wonderfully revealed during dismantling or restoration of old structures.

If plate-level tying joints were so complex, why did builders cut them? There were compelling reasons for carpenters to make the tying joint at the plate. Structurally, for resisting the outward thrust of the roof, it's hard to improve upon the rigid triangle formed when the rafters tenon directly into the tie beam. A rigid triangle at each cross-frame maintains the integrity of the roof marvelously. Second, during the scribing process (and most plate-level tying joints are from the period when frames were laid out on the ground and scribe-fitted), it was a procedural advantage to have the ties and plates at the same height and joined to each other. Finally, in early American barns the tie was often put at plate level for aesthetic reasons. In vertically boarded barns, the gable end boarding was usually lapped at the tie beam, forming a shadow line on the exterior (Fig. 4 and photo at right). Architecturally it was more pleasing to have the shadow line at the eave height than a couple of feet lower as in the dropped-tie barns typical of a later period. In fact, even in many dropped-tie barns, the end ties were framed at eave height to create the preferred exterior look.

THE ENGLISH TYING JOINT. Since the 1200s, this has been the tying joint favored in the British Isles, where it is commonly referred to as “normal assembly.” In English-speaking colonies here, it became the standard for houses and barns

until about 1800 and the advent of square rule layout. (See part I of this series for a brief description of this method.) The joint was then used occasionally until the waning of timber framing in the early 1900s. In story-and-a-half houses with a second floor kneewall, it was used for the corner tying joints across the ends, while the dropped tie was used on interior bents.

In its perfected form, the tie beam joins the plates with lap dovetails and is supported by jowled (gunstock) posts that tenon into both tie and plate. The rafters tenon into the top of the tie beam, forming a nice triangle and resisting outward roof thrust. The shallow lap dovetail in the underside of the tie beam, typically 1 to 2 in. deep, resists additional thrust put on the plate by intermediate common rafters and wind loading. To keep the lap joint together under wind loading and possible twisting action from drying, the tie beam is secured to a tenon (the teazle tenon, Fig. 3) in the top of the post jowl. The required extra width for the jowl at the post top was obtained by hewing from the natural swell of butt logs. The swelled end with its stronger fibers was placed up. In 17th-century houses, these jowls were often decorated with carved moldings. In later houses where the framing is encased by boards, the post tapers evenly from sill to tie.

The plate typically projected in length beyond the end wall of the building to provide relish past the dovetail. Though protected by the overhanging roof, a projecting plate end would still suffer from exposure. One solution was to extend the gable wall above the attic floor to conceal the joint. A different way to provide plate relish was to narrow the dovetail width toward the



Boarding lapped at tie beam.

inside edge of the tie beam, as far as practical (Fig. 6-4, overleaf). Or, instead of a dovetail, a cog was used that didn't require plate relish at all (Fig. 4). The cog also avoided another intrinsic problem of dovetails, namely shrinkage. In England, with its higher equilibrium humidity, shrinkage is likely less of a problem. But high initial shrinkage of the dovetail, exacerbated by American temperatures and humidity

swings, allows the plate to move outward under pressure, especially from any common rafters placed between the trusses. The result can be to split posts down the jowl, since the plate pushes on the back of the post and the teazle tenon in the front is restrained by the mortise in the underside of the tie beam. Many jowled posts are reinforced with iron today.

Figs. 1-3. Below, side-entrance, three-bay 23x32 barn in southeastern Massachusetts, ca. 1680. This barn has a steep 52-degree roof with 2x3 common purlins 24 in. on center trenched through rafters set about 6 ft. apart. A collar beam joins each pair. Unusually, one tie beam doesn't receive a rafter pair. At right, English tying joint with half-dovetail at the gable end. The plate, originally longer, now extends only 2 in. past the tie beam. A groove in the underside of the tie beam (Fig. 3) accepts the boarding.

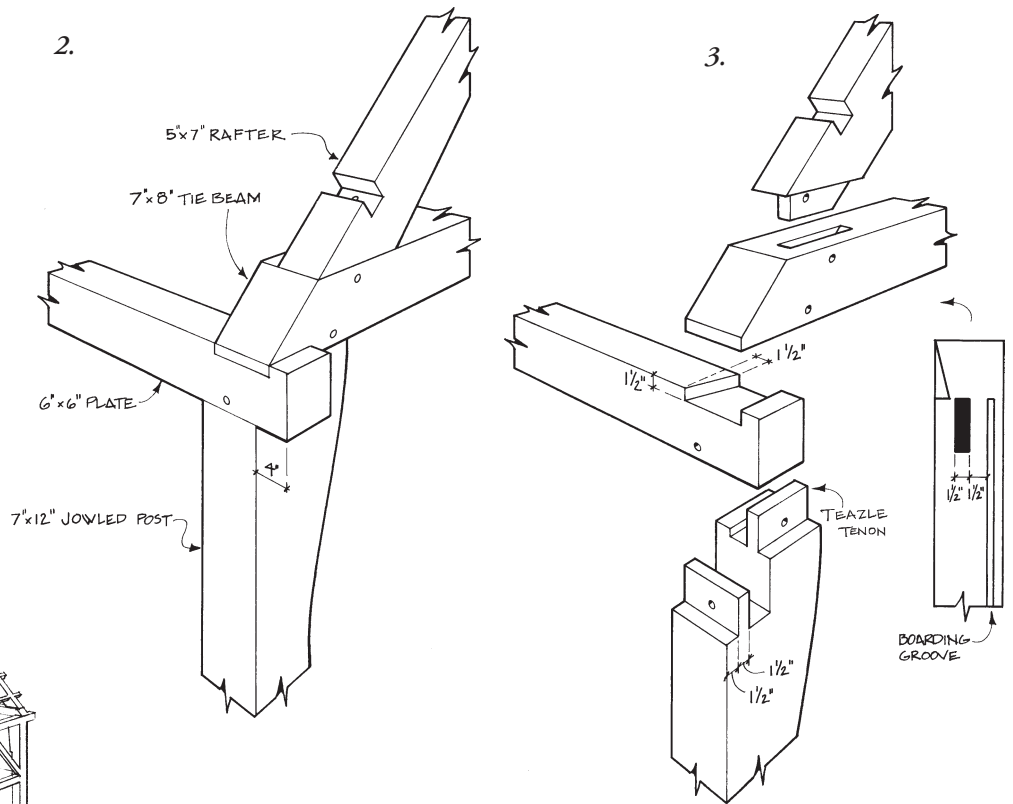
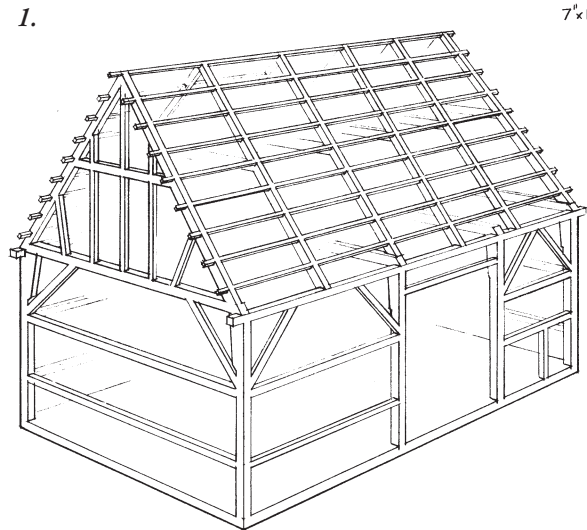

Drawings and photos Jack A. Sobon

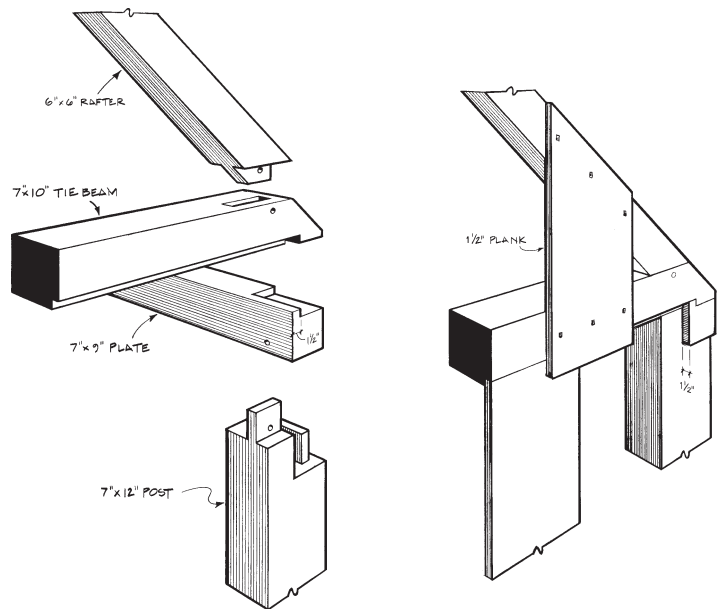

Fig. 4. Full-width cog (1/2 in. square) found on the corner joints in a 1773 three-bay 28x36 barn in Adams, Massachusetts. This barn has dropped tie beams on interior bents. Note lapped end boarding.

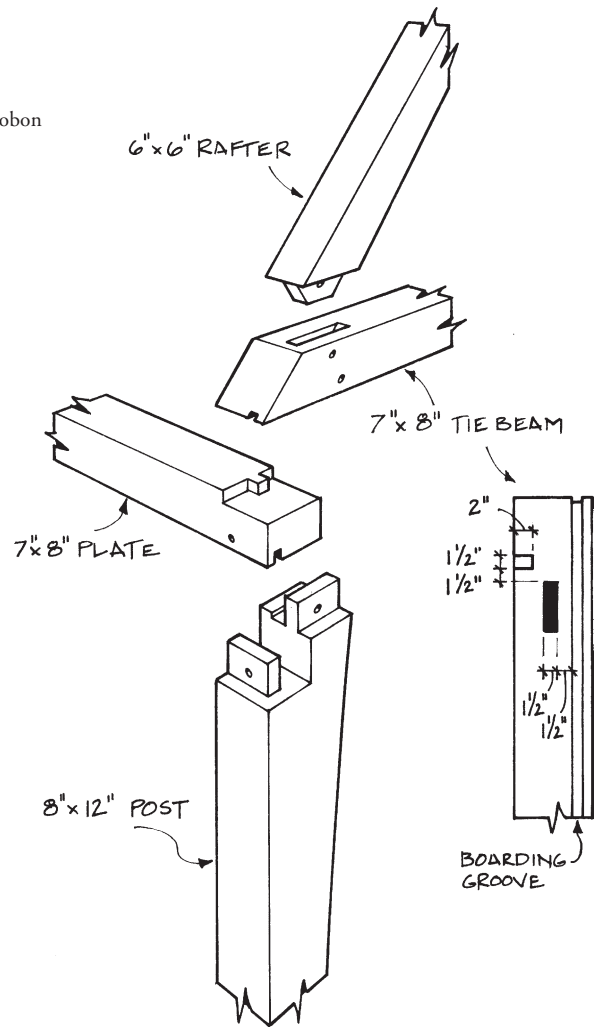

Fig. 5. In this corner tying joint from a 30x42 barn (1715) in Uxbridge, Massachusetts, a cog is used instead of a dovetail for the four corner tying joints to address the plate relish problem. Both plate and tie are grooved for vertical boarding.

To reduce stress on the posts, some builders added more tie beams, one for each rafter pair. Thus each rafter pair makes a rigid triangle and there is no longer any thrust on the plate. Each tie functions as an attic floor joist, sometimes spanning the width of the house. On wider houses the intermediate ties framed to a summer or spine beam, shortening the span. The principal tie beams were the full width of the house and often in conjunction with jowled posts. Extending all these tie beams over the plate could support a boxed-in cornice. The ties could be dovetailed, notched or cogged over the plate.

Other variations of these joints where ties and joists lap over the plate can be found in Tidewater Virginia. Here, the attic floor level is a few inches above the plate. The tie beams are lap dovetailed, and the joists simply notched to go over the plate. A raising plate, originally a timber but later a plank (Fig. 8), is nailed across the tie and joist ends for the rafters to bear on as in three of the flush lap examples described later. (See "The Eighteenth-Century Frame Houses of Tidewater Virginia," by Paul E. Buchanan, in *Building Early America*, ed. Charles E. Peterson, 1976. For additional New England variations, see Isham and Brown's *Early Connecticut Houses*, Cummings' *Framed Houses of Massachusetts Bay 1625-1725*, Kelly's *Early Domestic Architecture of Connecticut* and TF 36.)

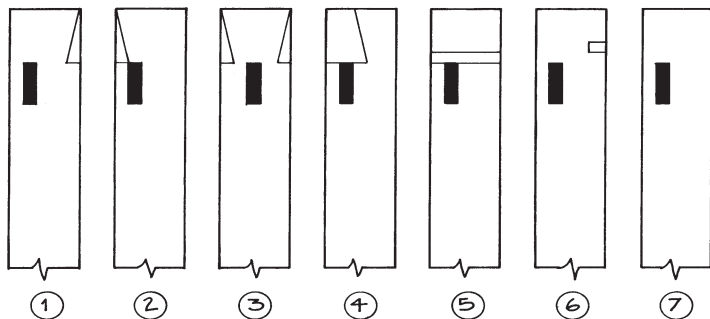

Fig. 6. Undersides of tie beam ends showing half-dovetails (1, 2, 4), full dovetail (3), cog types (5, 6) and one example (7) merely trenched across the plate.

FLUSH LAP TYPES. In houses, it's desirable to have the top of the tie beam flush with the top of the plate. But in frames with the traditional English tying joint, the attic floor is level with the top of the tie beams and thus several inches above the top of the plates. In medieval times when the tying joint originated, rooms were open to the roof and there was no attic floor to consider. Inserting an attic floor at tie beam level creates a somewhat awkward appearance at the plate (see photo on back cover).

The ceiling-wall junction is much cleaner when both the top of the tie and the top of the plate are in plane and, if the ceiling is to be plastered, when both timbers are the same depth. To gain this effect, various lap joints, some using dovetails, some with cogs, were developed. Many still used the jowled or tapered posts to secure the lap. There was much experimentation during this period. Many new joints emerged, and often more than one type appeared within a building. A few buildings have four different types! End joints were different from intermediate joints. Sometimes the front eave of the building had a different cornice from the rear. As the jowled or tapered post gave way to a post with a single top tenon, the joints became simpler.

Though strong enough in tension, these lap joints appear too weak to carry vertical loads. Often bearing only on its tenon, the tie beam receives no direct support from the post. However, such tie beams and plates are typically supported by plank partitions or timber studs, often for their whole length.

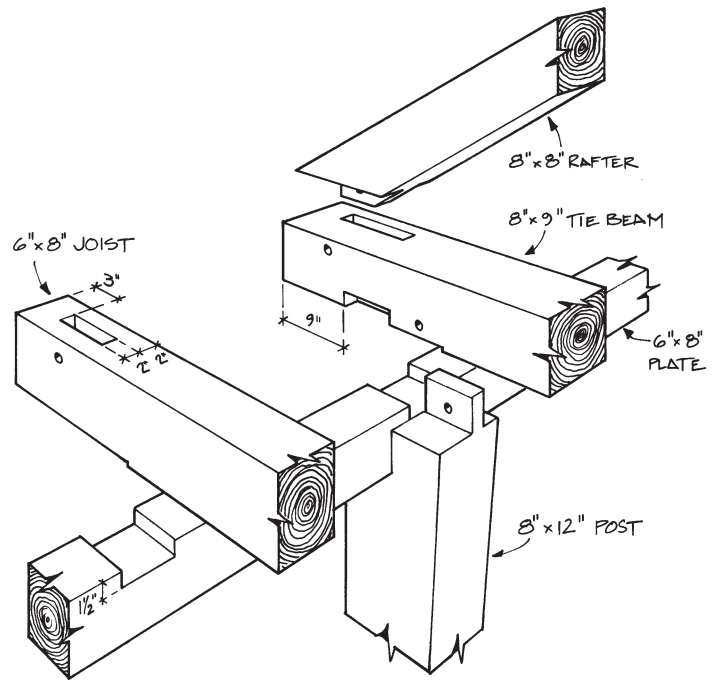

Fig 7. In this early 19th-century 32x40 two-story house in Washington, Massachusetts, the rafters tenon both into tie beams and joists, which extend 9 in. past the plate for a boxed-in cornice. The principal tie beams sit on tapered posts and are cog-lapped over the plate. The 6x8 joists do not run the full width of the house but frame into a central summer beam. They are notched through the plate without cogging. The roof has purlins framed between principal rafters and supporting the commons at mid-span.

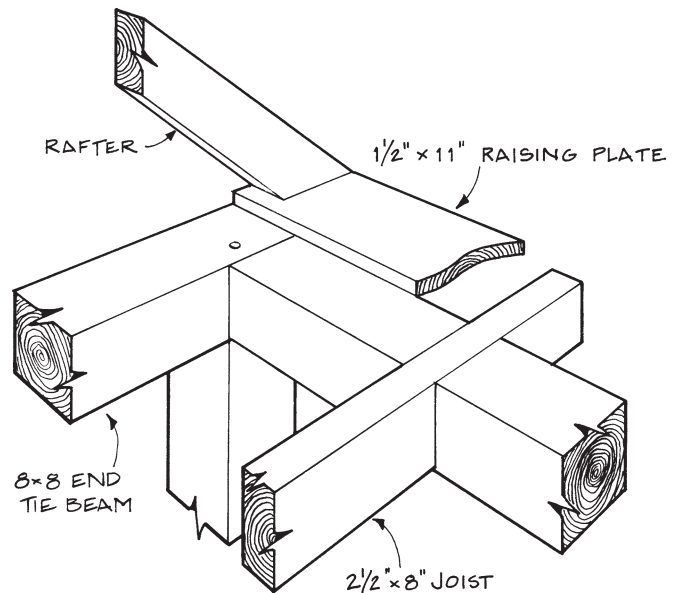
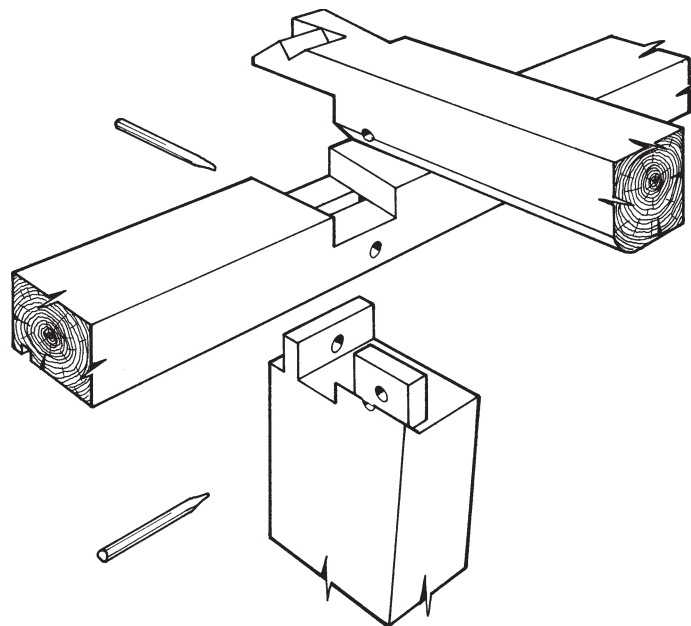
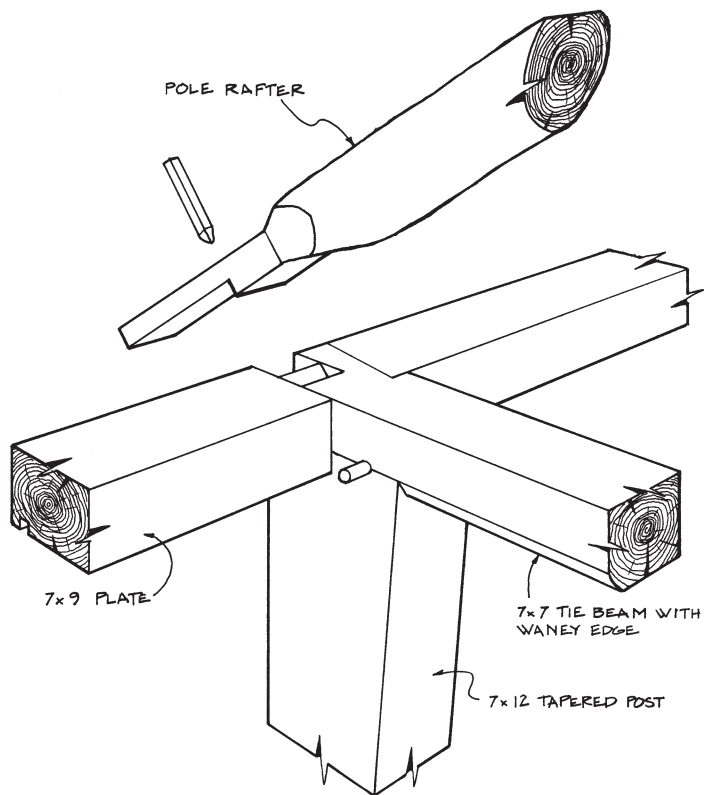
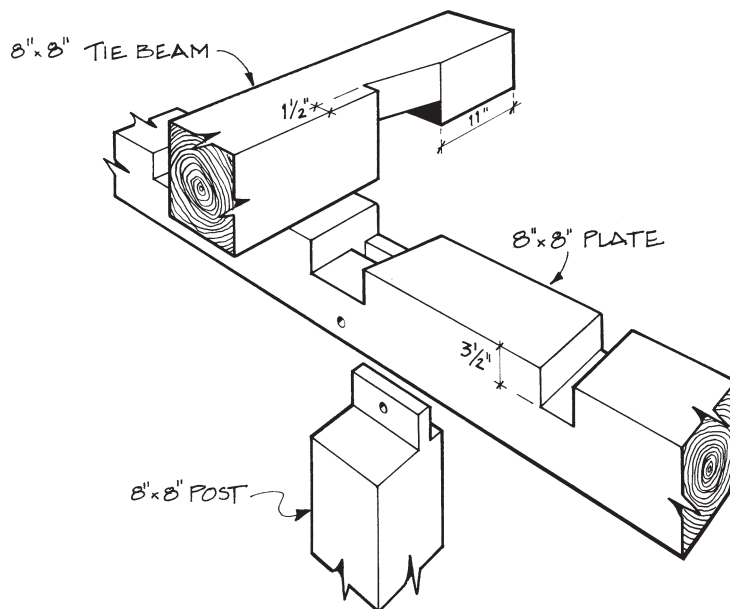
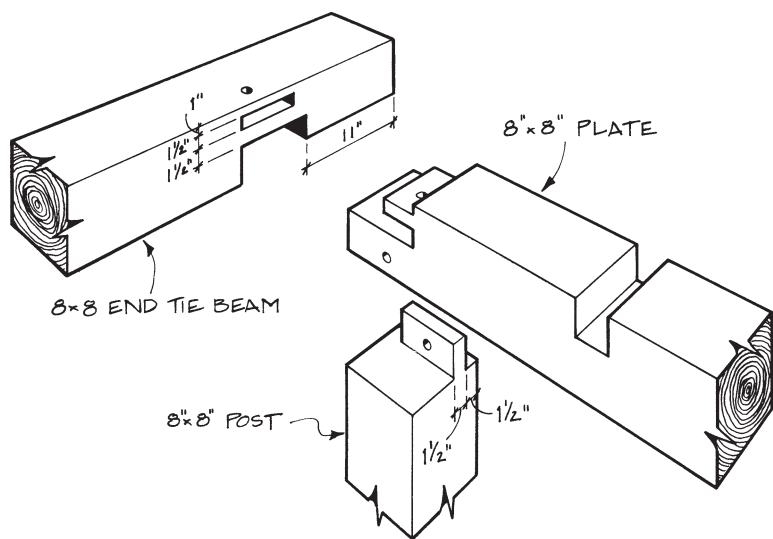

Fig. 8. A plank called a raising plate was nailed to both ties and joists, and rafters were nailed to it in turn. Attic floor boards butted to the plank. This arrangement was found in a 1791 house formerly standing in Cheshire, Massachusetts.



Figs. 9 and 10. This tying joint is found in a 28x38 three-bay, pre-1812 English barn in Goshen, Massachusetts. All of the tying joints are of this type. Instead of the rafter tenoning into the tie (as is more common), it is step-lapped, as are the intermediate common rafters to the plate. The post is scribed to meet the wane edge of the tie beam. (The corner joints are the same, without relish past the dovetail, but with rafter pins extending through the dovetail into the plate.)



Figs. 11 and 12. In the 1791 Cheshire house, a 30x40 Cape, non-jowled posts terminated in a single top tenon. Tie beams and floor joists extended 11 in. at the front eave to support a boxed-in cornice. At the front corners (left), a combination of lap, tenon and overhanging tie avoided the plate relish problem. The two intermediate tying joints on the front wall (right) were lap dovetails. Curiously, one had the dovetail reversed: a mistake? Additionally, all the floor joists notched through the plate for additional tying. At the rear wall (not shown), there was no overhang. Instead of lap dovetails, the intermediate tie beams joined the plate with a straight-forward 4-in. deep horizontal mortise and tenon, and at the corners the joint was the same as at the front sans the 11-in. projection. See also photo of frame on back cover.

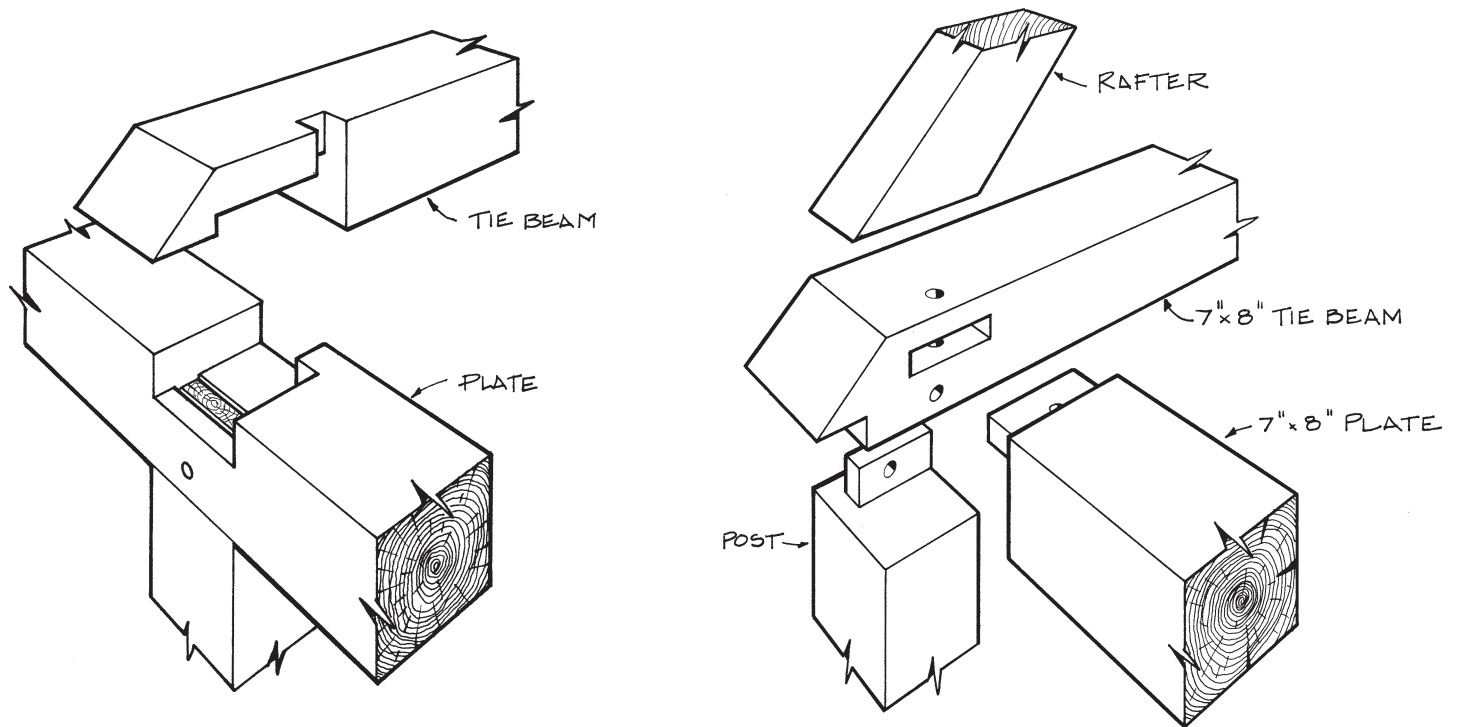

Figs. 13 and 14. A two-way cog was used in this lap joint in a 26x27 pre-1810 house in North Adams, Massachusetts. The tie beam end was notched on the bottom and the side to engage the plate. The cog measured 2x2½x3 in. The joists and ties extended about 7 in. to frame a cornice. At right, the end condition. A simple mortise and tenon is substituted for the lap.

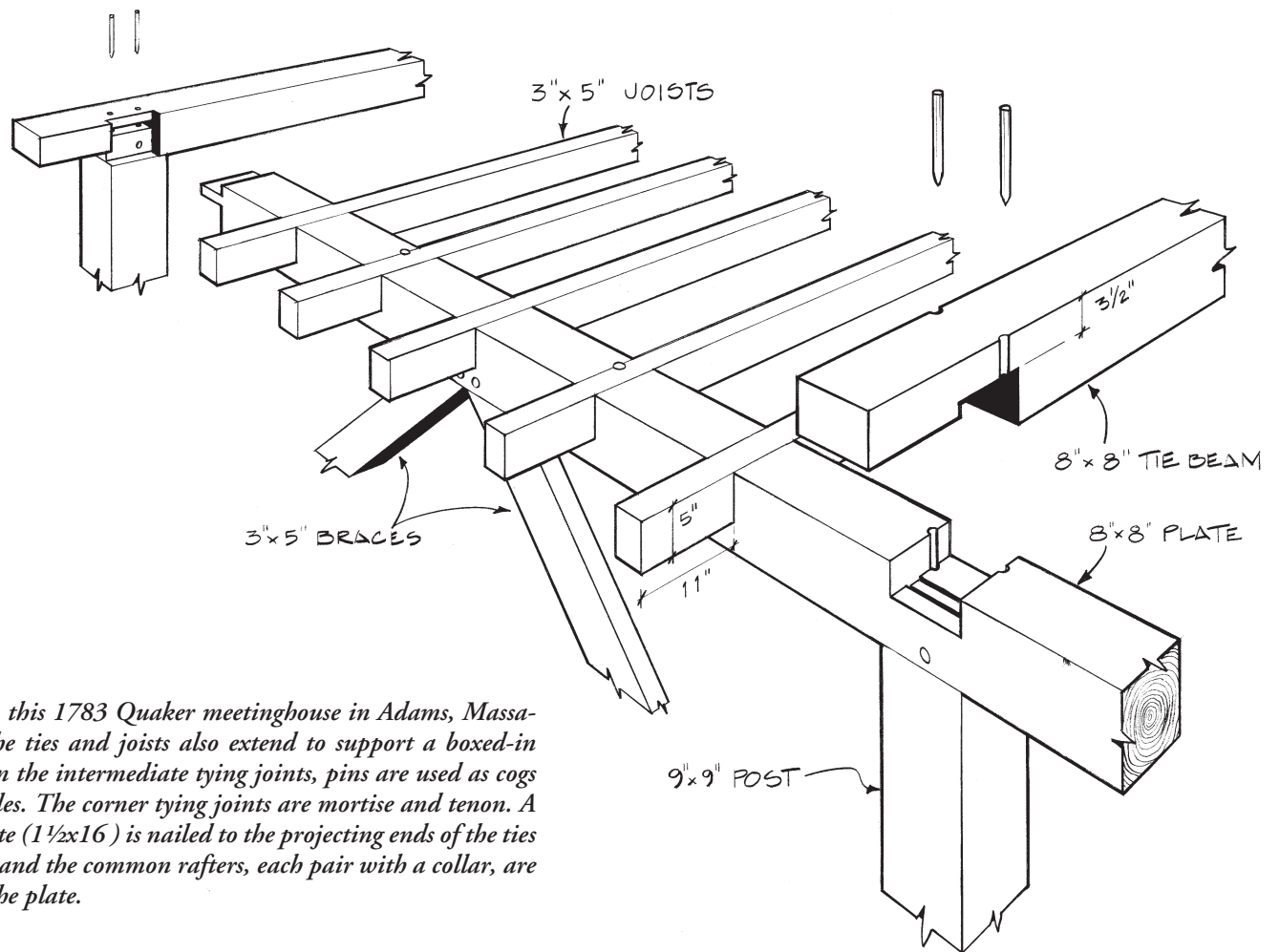
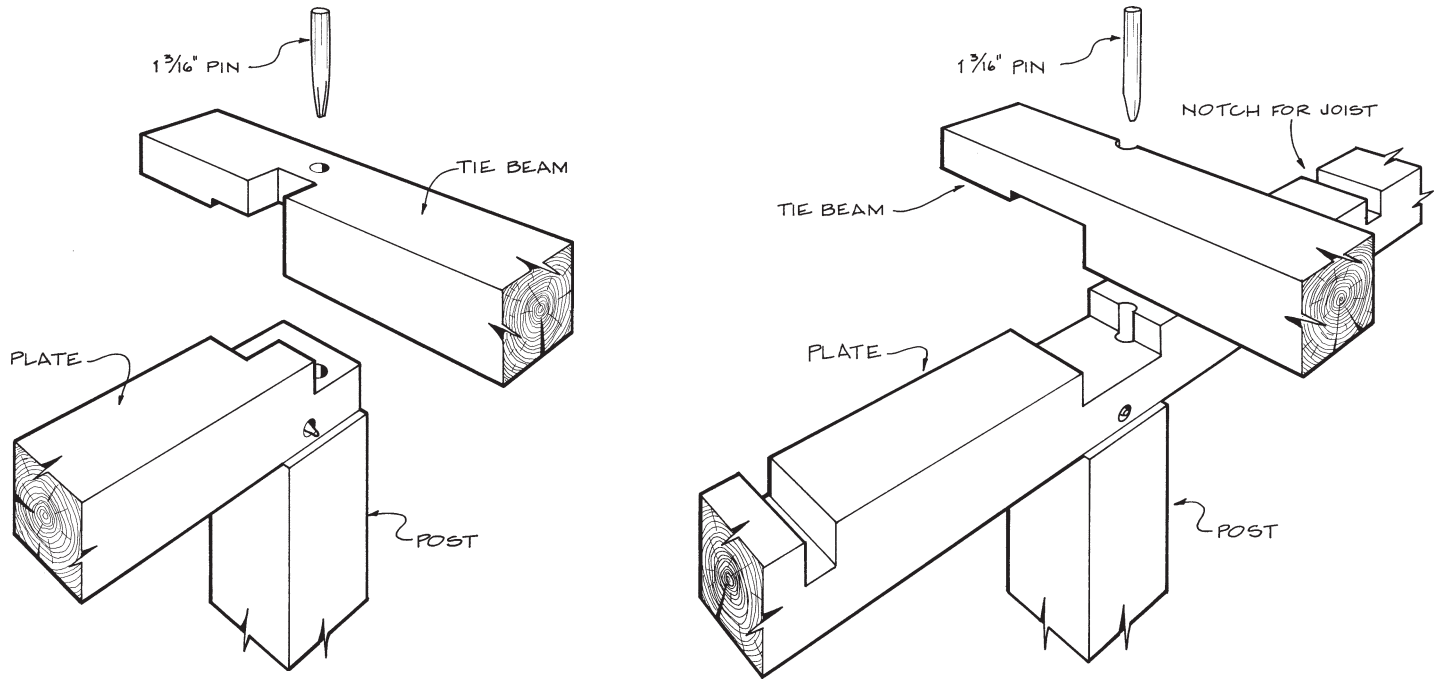
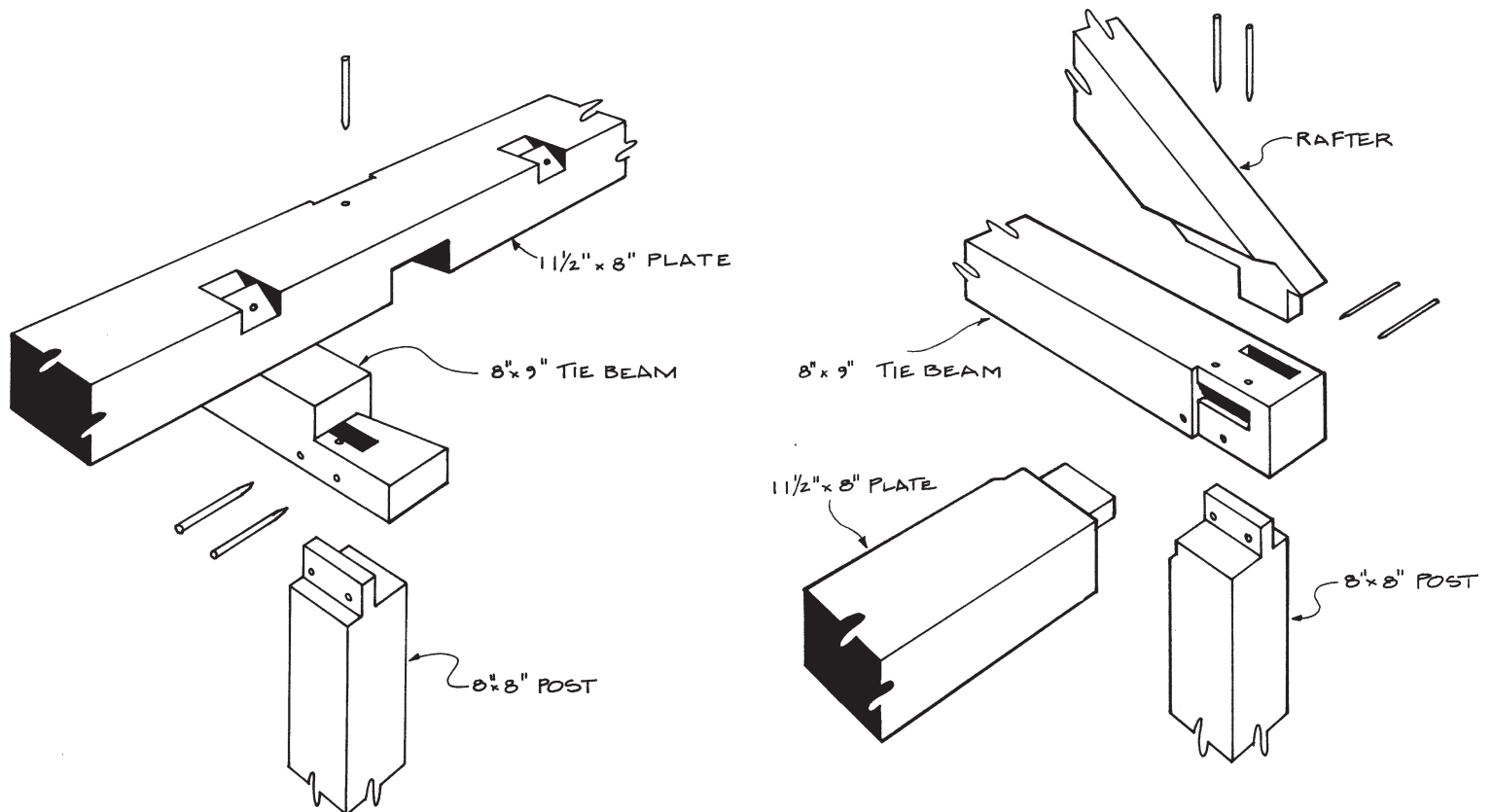

Fig. 15. In this 1783 Quaker meetinghouse in Adams, Massachusetts, the ties and joists also extend to support a boxed-in cornice. On the intermediate tying joints, pins are used as cogs on both sides. The corner tying joints are mortise and tenon. A raising plate (1½x16) is nailed to the projecting ends of the ties and joists, and the common rafters, each pair with a collar, are nailed to the plate.



Figs. 16 and 17. In this 26x32 Adams, Massachusetts, house (1785), the cog was used on the corner joints, the opposite of the North Adams house. An oversize pin was used to keep it in position. The hewn beech timbers were 7 in. square. On the intermediate joints, a single pin cog was utilized. This frame also had through notched joists and a plank raising plate with common rafters nailed to it.



Figs. 18 and 19. In a Charlemont, Massachusetts, house, now dismantled, the front plate lapped over the dovetailed end of the tie beam. A single pin also resisted movement. The plate, together with the tie beam dovetail, projected 6 in. to become a solid cornice base. The rear plate (not shown) did not overhang and the rear tying joints on the intermediate tie beams relied on through mortises and two pins. The common rafters step-lapped into the plate, except at the front corners, as shown (note hewn rafter tenon). The back corners did not project.

MORTISE AND TENON. The mortise and tenon joint performs better than a lap dovetail when shrinkage is a factor. Because the pin hole in the tenon is bored a little closer to the shoulder than in the mortise, or *draw-bored*, the pin pulls the joint together very tightly. The joint remains tight under normal shrinkage and loads. At the connection between tie and plate, the mortise and tenon gradually replaced the lap dovetail.

In its most basic form, the tie beam tenons into the side of the plate and is secured by one or more pins. There are countless examples of this joint. Many of these simple joints have not fared well over time, and spreading plates are restrained by cables. If the tie beam occurs over the post, much wood is removed from the plate.

It is prudent to stagger joints whenever possible. There are several ways to accomplish this. First, the plate can project from the face of the building, creating a cornice. Thus the post is tenoned into the tie beam, not the plate (Fig. 22). The drawback here is that diagonal braces can't be framed from the post up to the plate, only down to the floor beams or sill. In some houses framed plank-on-timber, there were no braces. The wide planks, well fastened to sill and plate, braced the walls.

Second, the tie beams can be offset from the posts. But end wall tie beams are outside of the plank wall and the plates cantilever out to support them. Again, braces can't be framed to them. On intermediate tying joints, a through tenon with two or more pins can be used or, better yet, a wedged through half dovetail (Fig. 23). Third, the plate can be raised and the tie beam deepened so that the post tenons into the tie beam instead of the plate. This tie to plate joint is an improvement over the normal mortise and tenon. Instead of the tie beam pins having two shear planes, they have three (Figs. 25-27). These mortise and tenon tying joints require a different raising technique. The plates must be slid horizontally onto their respective tenons and plate bracing is tricky to insert. A fourth method is to raise the tie beam above the plate (Fig. 24).

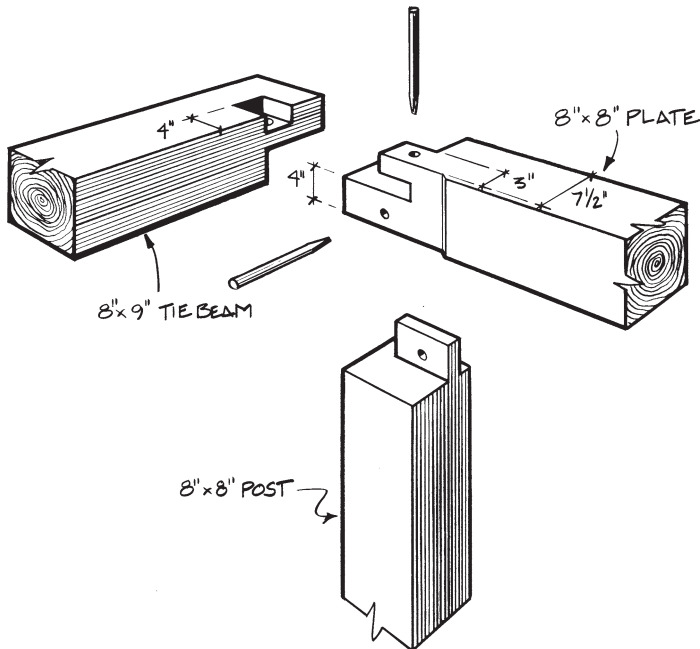

Fig. 20. This joint is a cross between a cog and a mortise and tenon, and occurs (as far as is known) only at the corners of a 1785 three-bay 30x40 barn in Adams, Massachusetts. The intermediate tying joints are the dropped type. The common rafters with collars are step-lapped into the plate except at the corners where they are butted and nailed.

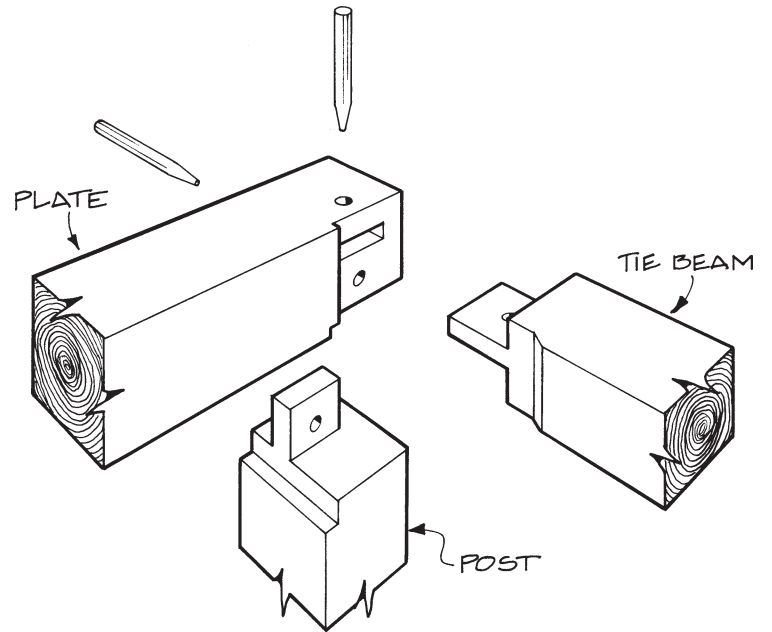

Fig. 21. This simple joint is found at the corners of a square rule barn in Huntington, Massachusetts.

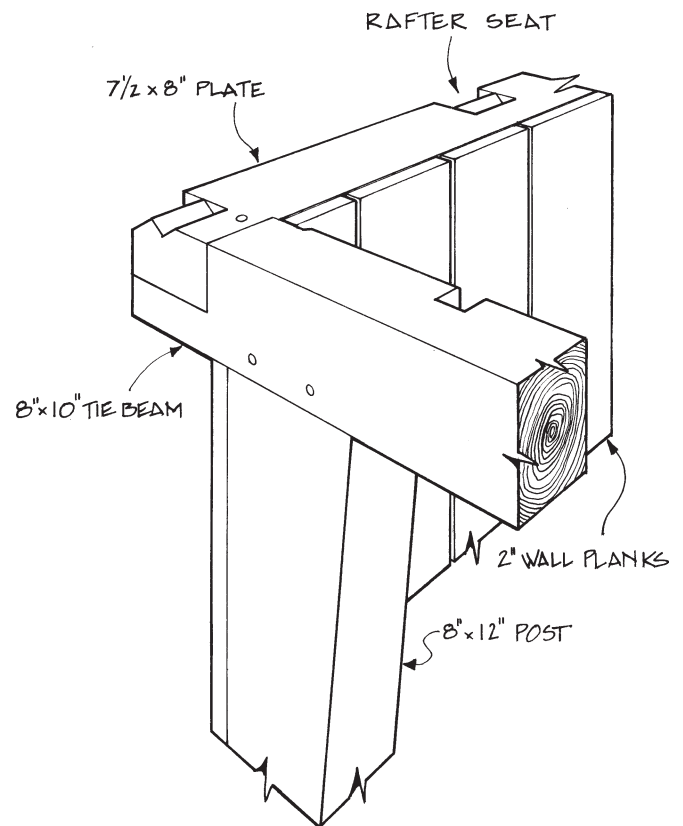

Fig. 22. In this Canaan, Connecticut, example (after 1810), now dismantled, the cantilevered plate projected enough to allow the wall planking to nail to the inside surface. The 6-in.-long tie beam tenons to the plate were secured by one pin at the corners and two pins on intermediate joints. The posts were tapered.

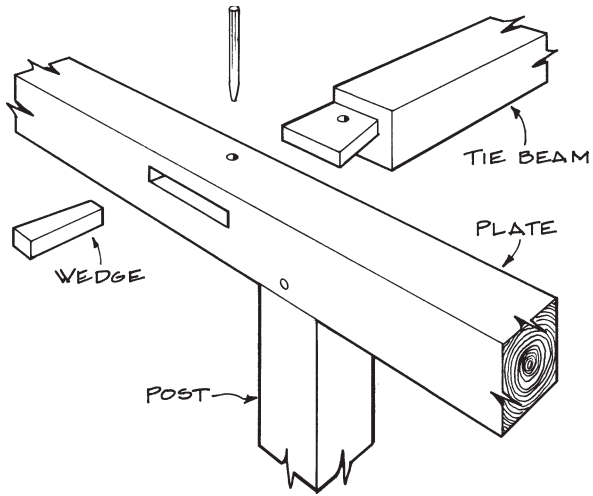

Fig. 23. This rugged offset tying joint, a wedged through half-dovetail mortise and tenon, is only used on intermediate tying joints.

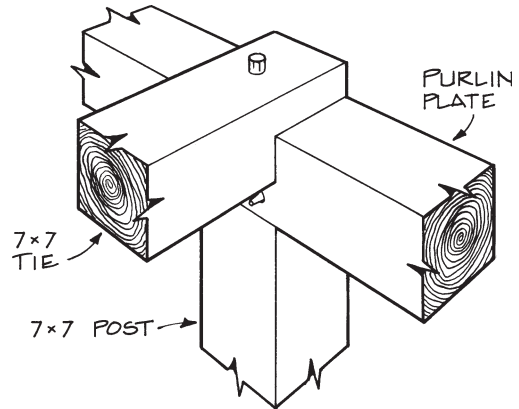
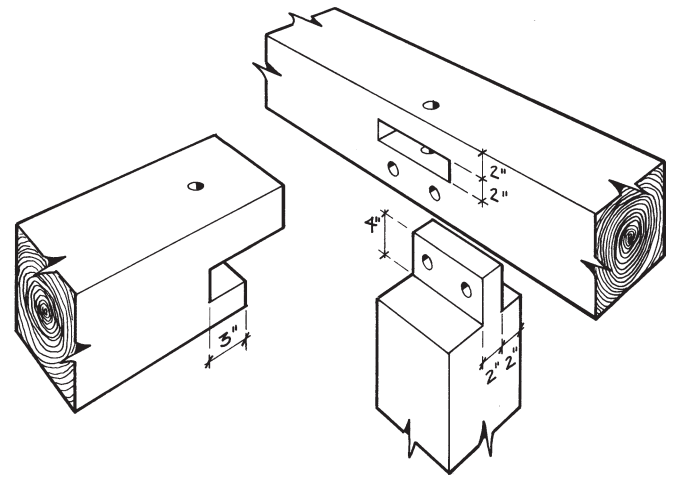
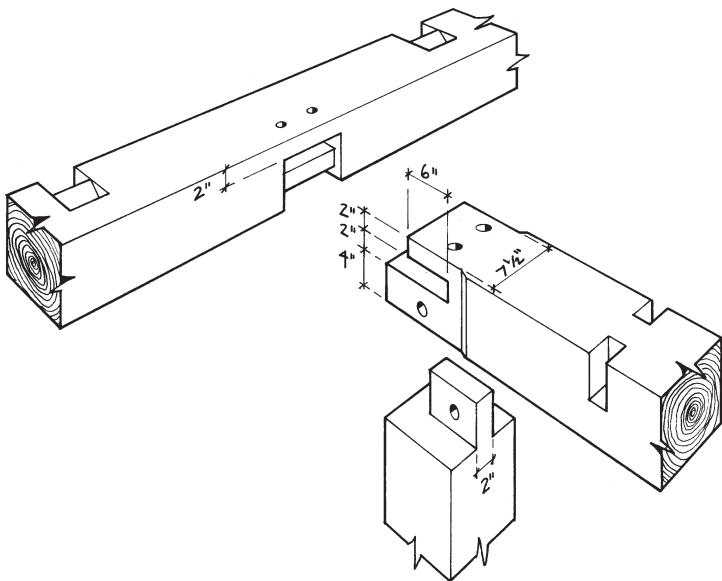
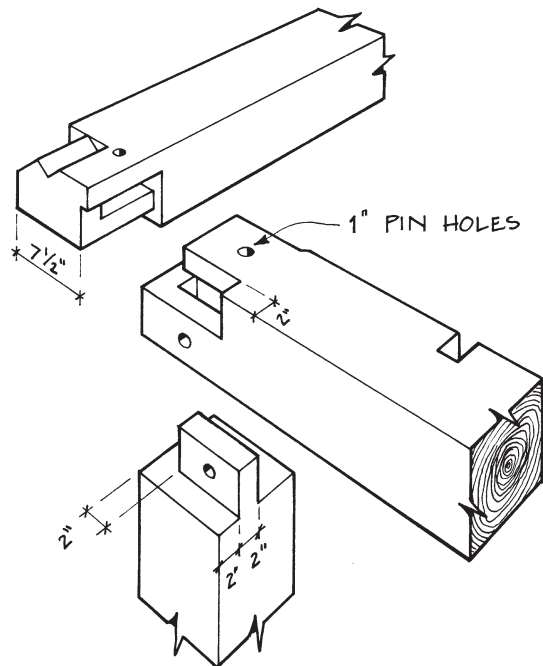

Fig. 24. This tenoned tie connects purlin plates in a barn in Goshen, Massachusetts. It also has an additional pin shearing plane in the tying joint.

25.



27.



26.

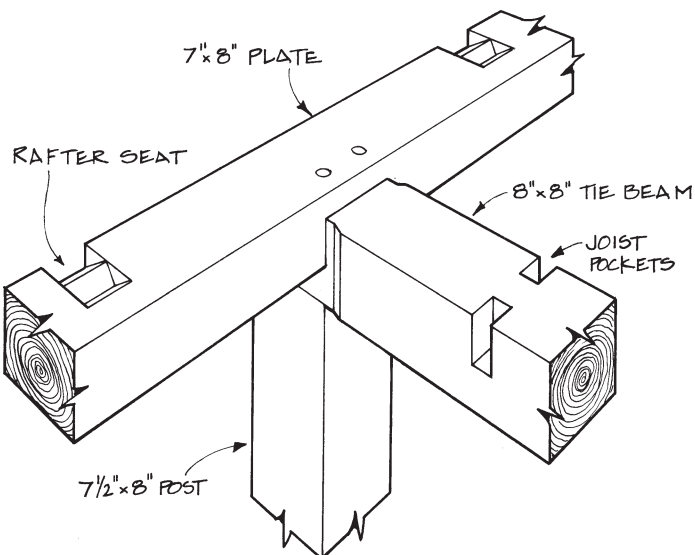

Figs. 25-27. Intermediate (Figs. 25 and 26) and end (Fig. 27) tying joints in a two-story 28x36 post-1810 square rule house in Windsor, Massachusetts. The plate is 2 in. above the tie, allowing the post to tenon into it. The braces from the post up to the plate fit elongated mortises and were apparently inserted after the plate was slid on, and the extra space in the mortise was then filled with a wedge. The end tying joint is similar but with 2 in. of plate relish and only one pin.

TRIPLE BYPASS. This is arguably the most perplexing of tying joints located thus far. It is found along the border of New York and New England in four states. Some refer to it as *secret* joinery because it can mystify the casual observer. Its name, coined by Don Carpentier of Eastfield Village in East Nassau (Rensselaer County), New York, is apt. The connection has three mortise and tenon joints, not counting the rafter joint (Figs. 28-30). In Buskirk, New York, a barn with all of its tying joints of this type shows evidence of having been dismantled previously. All the tie beam tenons are inserts (free tenons). Undoubtedly the dismantler was perplexed at how to take the barn apart. He cut the tenons off (a hanging offense in my book) and then spent considerable time putting tenons back on.

How was such a joint assembled? Different bent configurations would call for variations, but all would involve blocking up either the plate or the tie to allow the other to slide on over the post tenon. In a Shaushan, New York, barn, the post tenon into the tie beam is a couple of inches longer than the one into the plate. The tie beam could be blocked up high enough to allow the plate to slide on but still be engaged on its tenon. This particular builder, I would say, had raised more than one of these barns.

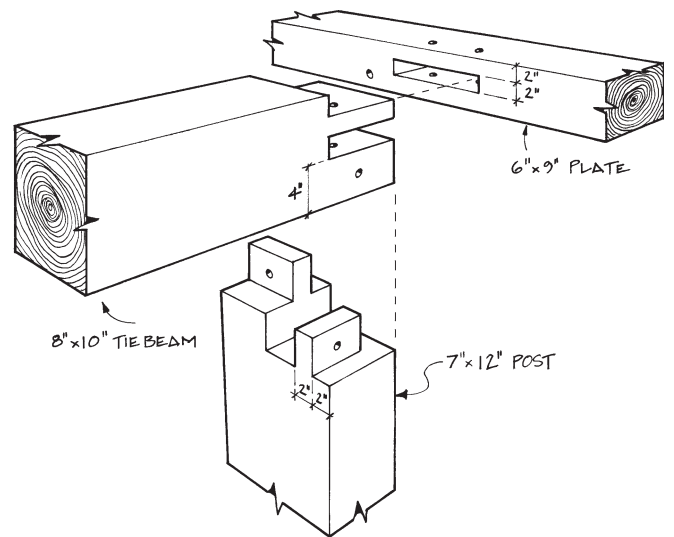
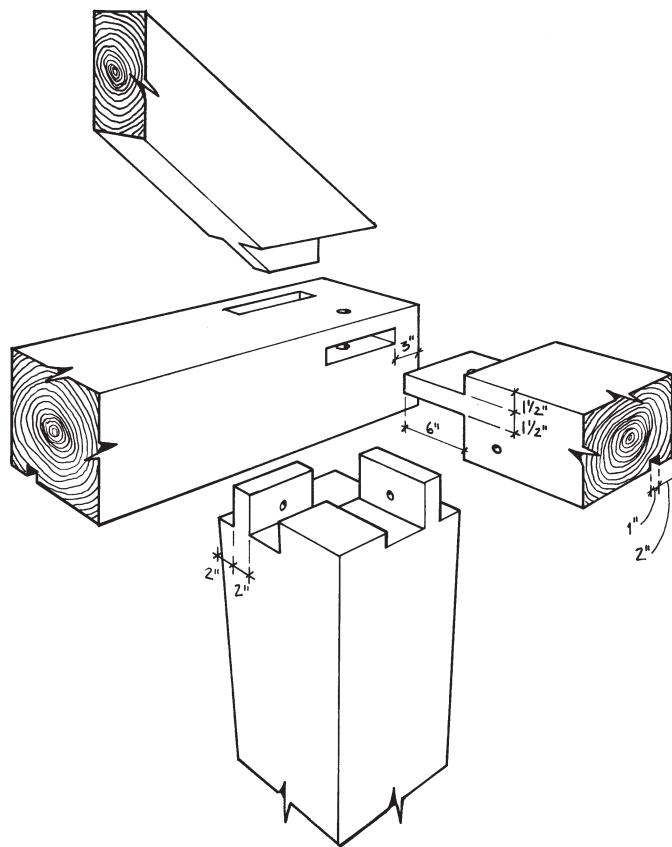
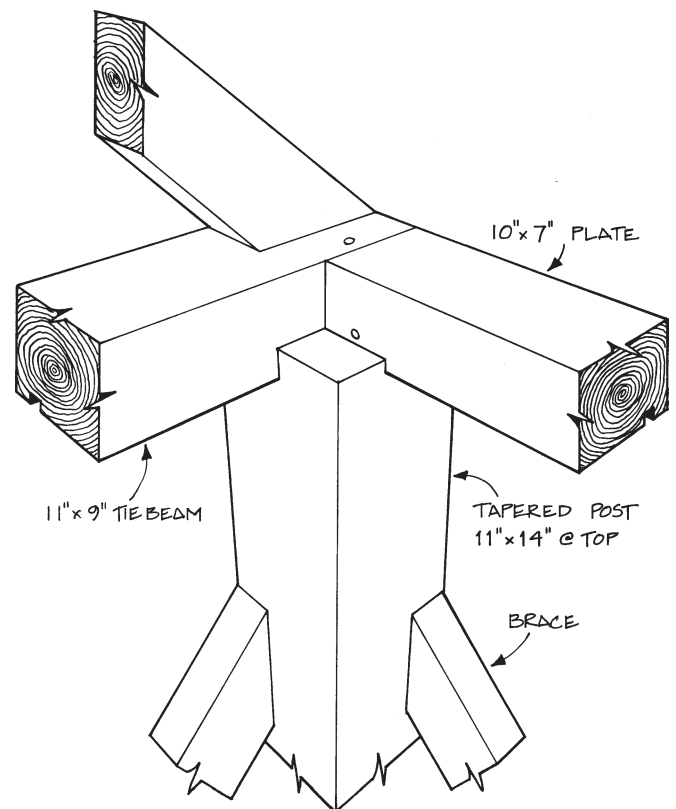

Fig. 30. A triple bypass joint in a 26x38 three-bay, side-entrance barn in Richmond, Massachusetts. All eight tying joints in the barn are of this type. End joints are of course provided with plate relish. The tying pins have an extra shear plane. This early scribe rule barn was framed before 1810.



Figs. 28 and 29. This triple bypass corner tying joint was found in an early scribe rule (late 1700s) four-bay, side-entrance barn in Hoosac, New York. The 36x49-ft. barn appeared to be Germanic in origin, with purlin plates and a ridge beam. Intermediate ties were the dropped type. Long braces extended German-fashion from the sill up to the corner posts. These undoubtedly helped stabilize the structure during the setting of the plates. Boarding grooves were worked in both plate and tie. This barn was carefully dismantled but unfortunately burned while in storage.



INTERRUPTED PLATE. In the early 19th century, a new barn type emerged in New England, a gable-entry, aisled barn that could vary in length from two to 10 bays (or more). Bays were typically 12 ft. Such barns were often built into side hills to allow access on more than one level. Figuring prominently in their design was a frame with interrupted plates. These shorter plates, tenoned between tie beams or posts, allowed standardized joints and components. A builder could vary the size without changing the design. Bents were raised and connected by plates and braces. As soon as two bents were connected, the frame was braced and stable. There were variations in this joint depending on cornice design. Some barns had two plates. One was in the normal position to receive the tops of the wall boards. The second tenoned between the projecting tie beam ends to support the fascia and soffit.

The interrupted plate was not an improvement over the continuous plate. Wind loads cause the plate braces to exert tension on the short plate tenons, typically 3 to 4 in. long, which can handle only small tension loads. But roof boarding, flooring and cornice work often provided enough continuity to make up for what the continuous plate had provided, and some barns had continuous purlin plates with a scarf where necessary. Some houses as well were built with interrupted plates, but by this period balloon framing was becoming popular for houses, and timber framing was in decline.

—JACK A. SOBON

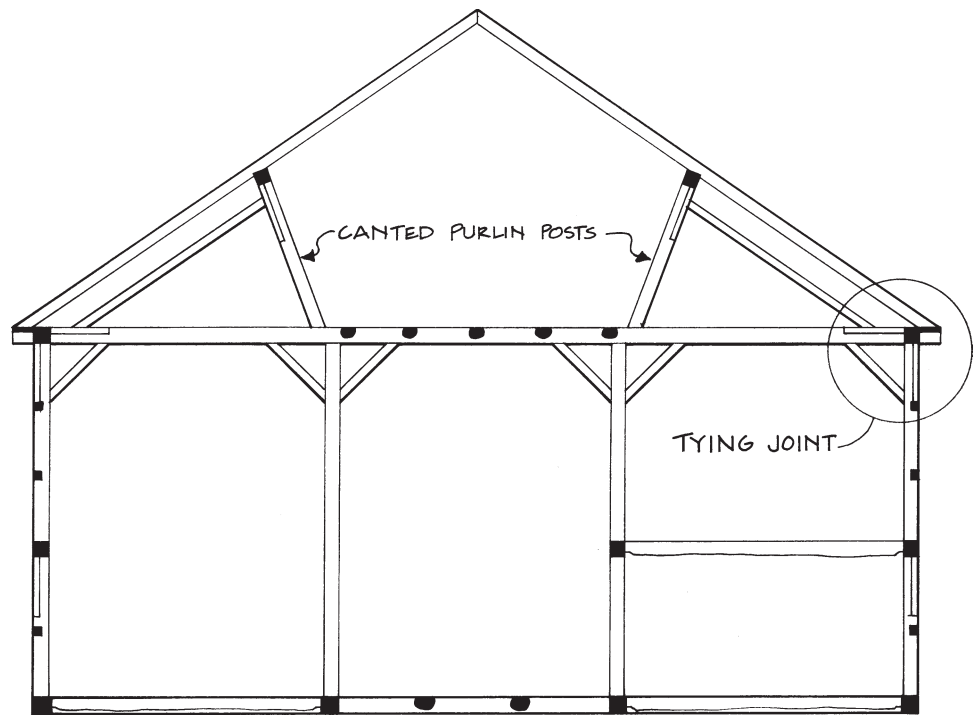

Figs. 31 and 32. This ca. 1850 barn, now rebuilt elsewhere, stood in Shrewsbury, Massachusetts. Measuring 37x50, it has canted purlin posts, continuous purlins and interrupted plates. All principal timbers are 7x7. To support a substantial Greek Revival cornice, the builder has inserted outriggers into the plates and secured them with nails (Fig. 32 below). A 2x11 raising plate is nailed to the outriggers, and the projecting tie beam ends stiffen the assembly and support the rafters. Braces in three planes reinforce the structure.

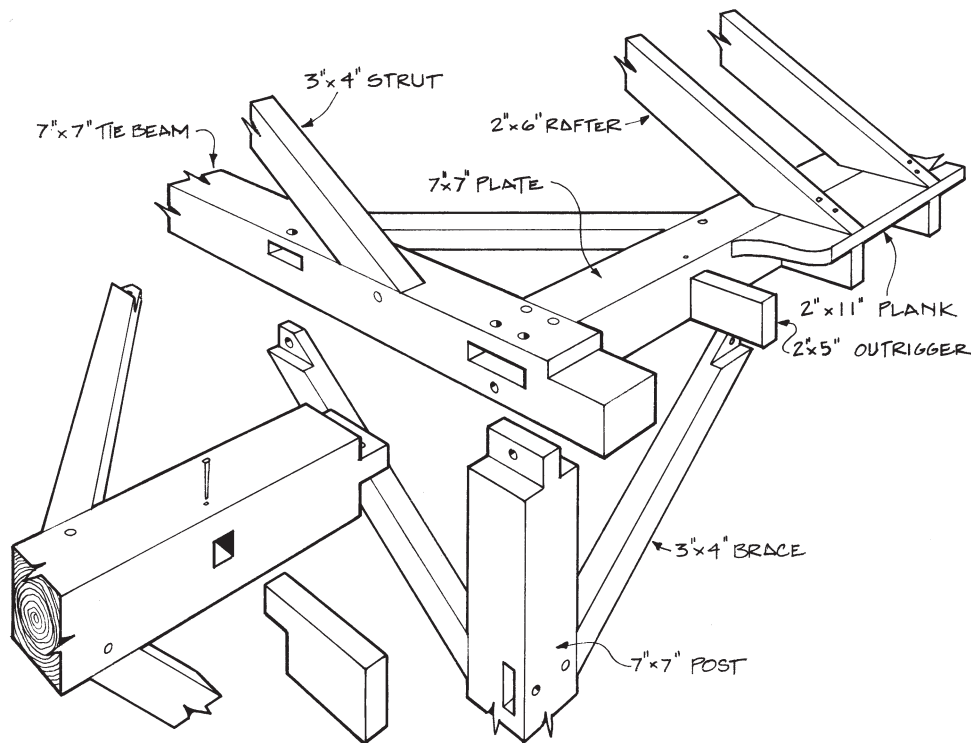

Jack A. Sobon

The English tying joint tradition lives on even with interrupted plates in this Newfields, Maine, aisled barn. The plates tenon into the side of the post and a flying plate (not visible) is supported by the tie beam ends.