

Historic American Timber Joinery, A Graphic Guide

THIS article is first in a series of six to discuss and illustrate the joints in American traditional timber-framed buildings of the past, showing common examples with variations as well as a few interesting regional deviations. The series will not describe the cutting process (that is best left to the “how to” books), but it will occasionally mention whether a joint is simple to fashion or labor intensive. Structural merits will be discussed only in general terms. Most of the research underlying the articles has been done in the heavily timber-framed northeastern United States, but the findings are applicable over a much wider area. This series was developed under a grant from the National Park Service and the National Center for Preservation Technology and Training. Its contents are solely the responsibility of the author and do not represent the official position of the NPS or the NCPPT. The six articles, to appear in successive issues of *TIMBER FRAMING*, will be entitled, respectively :

- I. Tying Joints (Tie below Plate)
- II. Tying Joints (Tie at Plate)
- III. Sill and Floor Joints
- IV. Wall Framing
- V. Roof Joinery
- VI. Scarf Joints

I. Tying Joints (Tie below Plate)

OF all the joints that make up a traditional timbered frame, the most important are the tying joints. Tie beams, also referred to as crossbeams, anchorbeams, ties and lower chords (in trusses), are transverse horizontal members that span from wall to wall or eave to eave, resisting the outward thrust of the roof planes. Where the tie beam joins the wall framing, we have the *tying joint*. Tying joints are usually the only connections in a frame that must resist tension. When a tie beam joins the feet of principal rafters, the result is a triangle, a rigid structural shape. In wide structures, rafters are often supported by purlin plates somewhere in mid-span, and their effective span is thus shortened (see Fig. 2). Support by purlin plates normally reduces outward thrust of the rafter at the plate and consequently the load on the tying joint. But wind loads can cause bracing to exert tension loads on the tying joint. (See, for example, Ed Levin, “Frame Engineering,” TF 30.) In aisled structures, the tie beams may not be continuous across the entire width, but may span from post to post of the aisles. Of all the joints in a frame, the tying joints especially must be of good structural design and each one well crafted (there is no redundancy).

Because of their complexity and variety, tying joints may conveniently be divided into two groups: tie below plate and tie at plate. This article will focus on the former group.

The tie below plate, or *dropped tie* as it is often called, joins the wall posts below the plate. Its connections are generally simpler than those of the tie into plate and probably its configuration is the more widespread. Since it lies below the plate, occasionally several feet, and the rafters join to the plate, it doesn't create the nice triangle with the rafters that engineers like to see. The rafters carry roof thrust to the plate. The plate transfers the load to the post. The posts are joined by the tie beams. Each joint must be sufficient to carry the load, and the post must not break.

If the load path is convoluted, why did the arrangement arise? In traditional timber framing it is often simpler and stronger to stagger joints. When a joint is cut in a timber, wood is removed

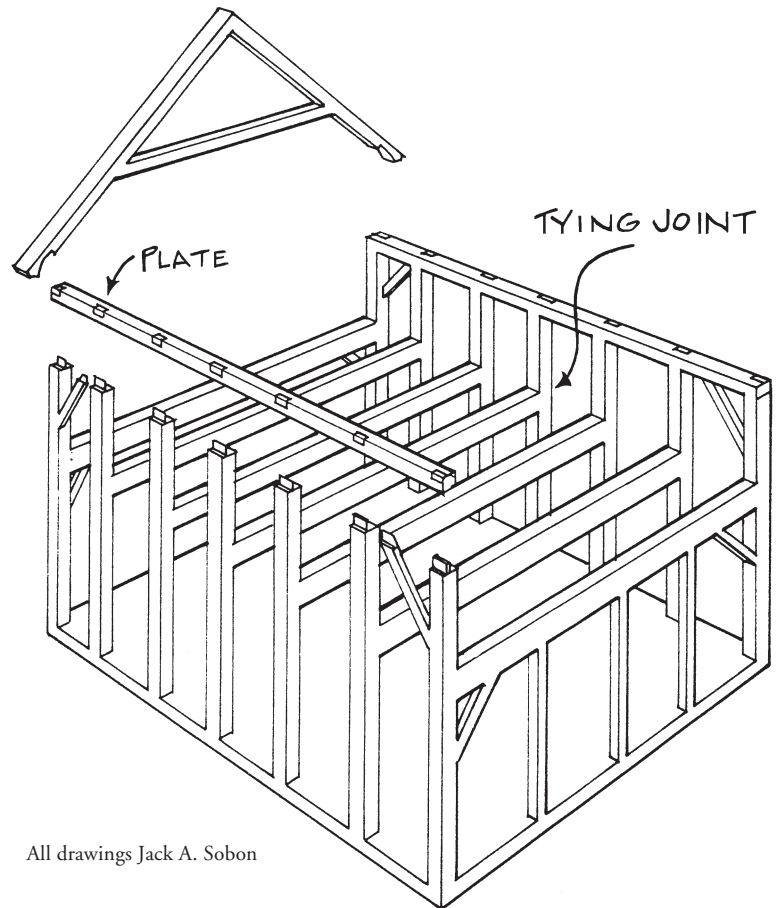

All drawings Jack A. Sobon

Fig. 1. In the typical New York State timber-framed Dutch house, the plate is 3 to 4 ft. above the second floor. The closely spaced H-bents, typically 3 to 5 ft. on center, illustrate the tie-below-plate condition.

and the timber's strength is diminished. Joining multiple members at the same location often creates complex joinery and can weaken members excessively. Raising the plate a foot or two above the tie avoids this problem, and raising the plate several feet above the tie also makes the space under the roof more usable.

The Through Mortise and Tenon (Figs. 3-5). Probably the most prevalent tying joint in America, the through mortise and tenon was the standard joint in the carpenter's repertory where a joint was subject to tension loads. The mortise is cut completely through the post to maximize the tenon length. Because the connection relies entirely on the pins to resist withdrawal, pin size and location are critical. Failure of this joint can occur in five ways:

1. The pin can shear off (pin too small or decayed), and the joint withdraws.
2. The wood in the tenon between the pin hole and the end of the tenon, called the *relish*, can split out (tenon too short or pin hole too close to end of tenon), and the joint withdraws.
3. The mortise face can split out (pins too close to face), and the joint withdraws.
4. The post can split in a line from the pin hole up to the post's top tenon (joint too near the post top), and the top portion of the post breaks away.
5. The post can break off at the tying joint (too much cut out of the post).

Generally, through tenons are used to maximize the relish in the

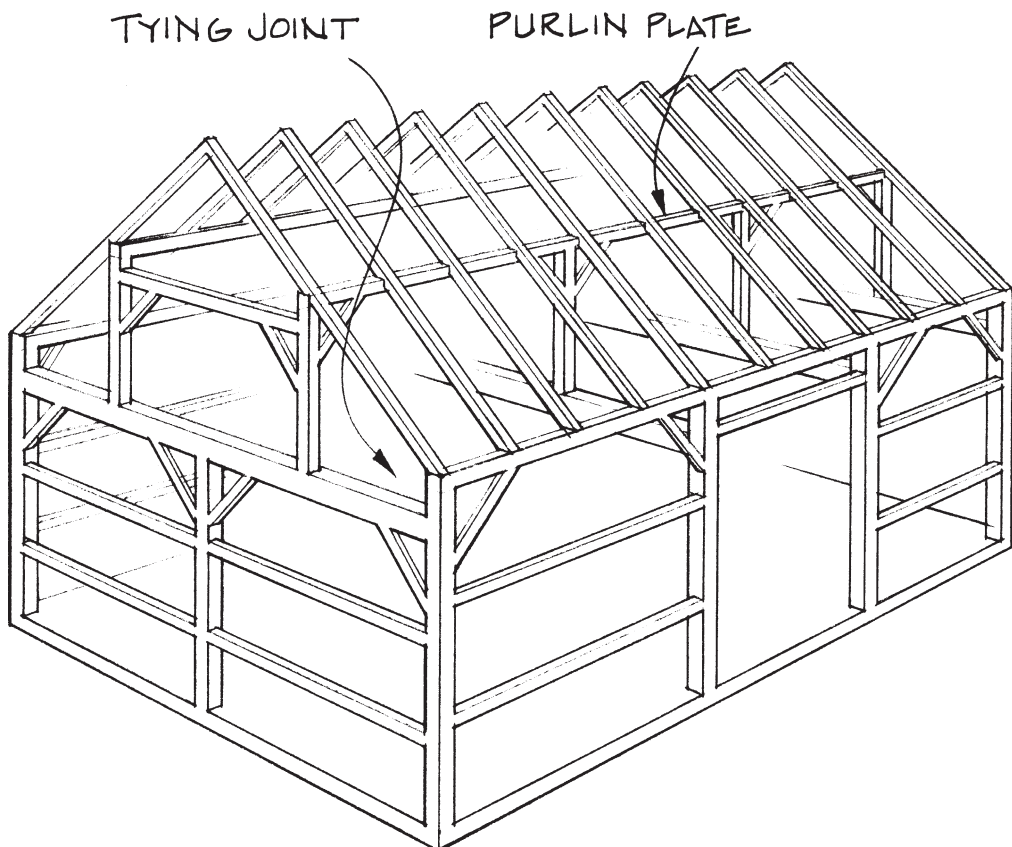

Fig. 2. The three-bay, side entrance barn, common throughout western New England and New York after about 1800, made use of the tie-below-plate tying joint. The rafters were additionally supported by continuous purlin plates at their midspan.

tenon beyond the pin hole, but a few blind (not through) tenons have been found. The use of two or more pins is common, often not in line to avoid mortise face split out. Some typical pin placements are illustrated in Fig. 5.

In most buildings, this joint is housed because the tie beam often carries floor loads. Instead of the tenon alone, the full width of the beam bears on the post; a substantial increase in bearing as well as shear strength is accomplished. A diminished housing is typical in scribe rule frames, a parallel housing in square rule frames. (Square rule frames are marked and cut according to a

Fig. 3. The through mortise and tenon. In its most basic form, it handles moderate loads. This simple tying joint occurs in countless buildings of every period and nationality.

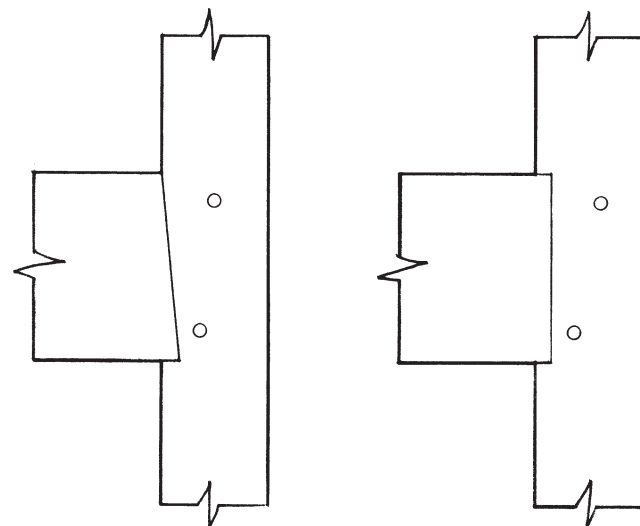
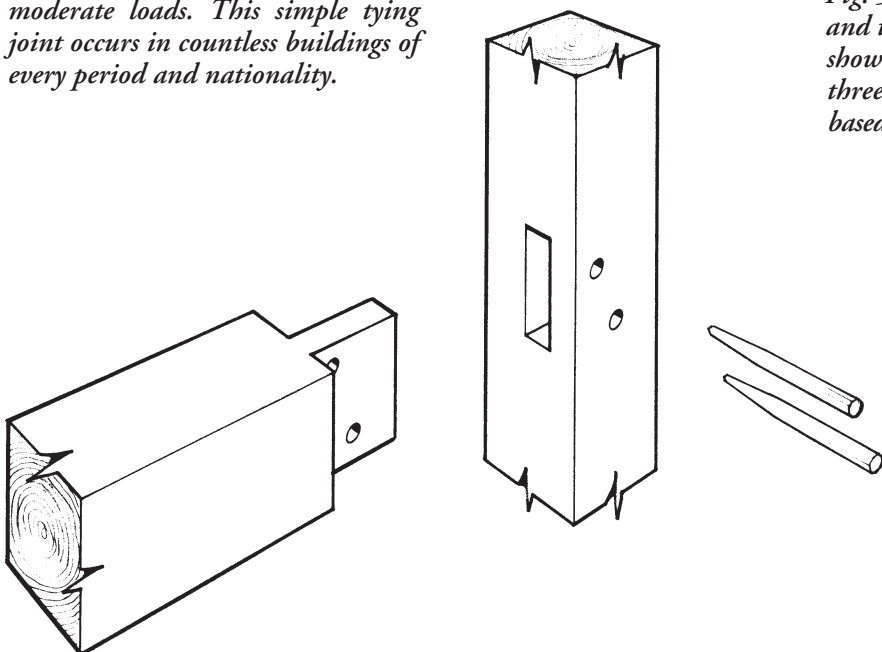
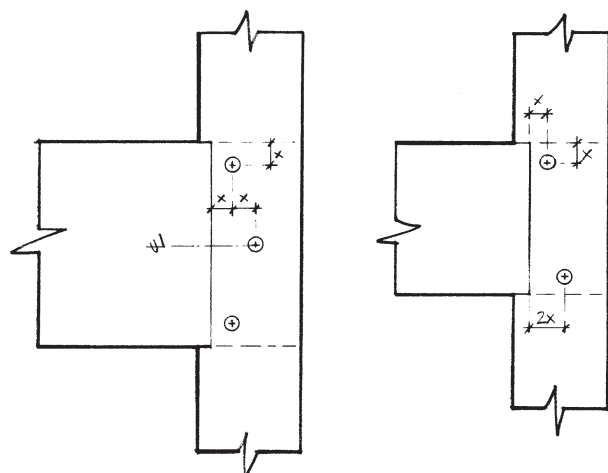

Fig. 4. The two basic types of housed through mortise and tenon joints. The diminished housing (on the left) was primarily used in scribe rule frames. The parallel housing (on the right) is found in both scribe rule and square rule frames.

Fig. 5. Pin number and placement varied with the size of the member and the preferences of the builder. Members 6 in. deep or smaller (not shown) usually have one pin; 7 to 10 in., two pins; and above 10 in., three pins. The distance shown as "x" is often either 1½ in. or 2 in., based on the tongue or blade of the framing square used by the builder.



Blind-Housed Through Mortise and Tenon (Figs. 6 and 7). When the post face is wider than the tie beam, the tie beam is often housed into the post. It may be set flush with the layout face of the post (for example, the outside face of an outside post) or centered. A wide post can minimize breakage at the joint. Occasionally a tie beam is reduced in width at its end to allow for a blind housing. This extra wood retained on the post adds considerable strength compared with a post whose face has been cut right across to form an open housing.

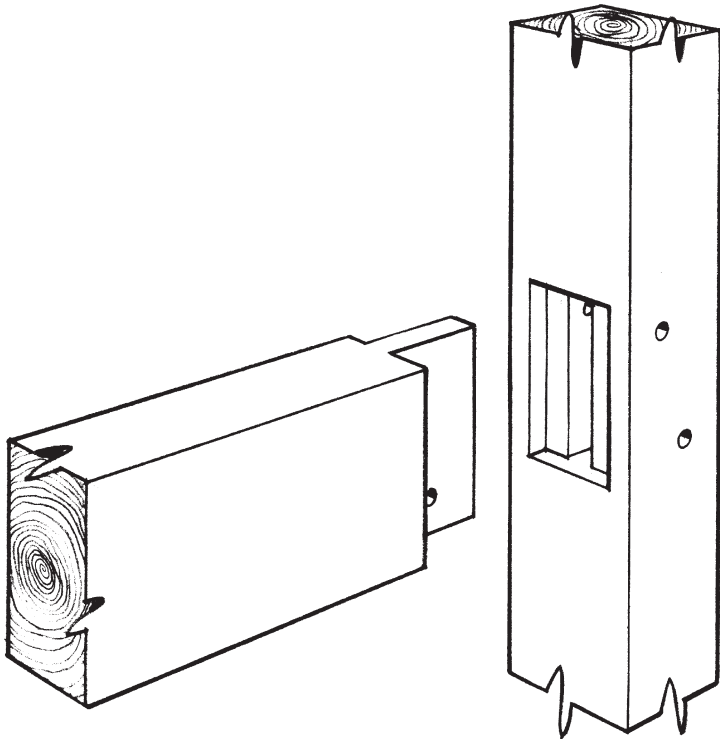
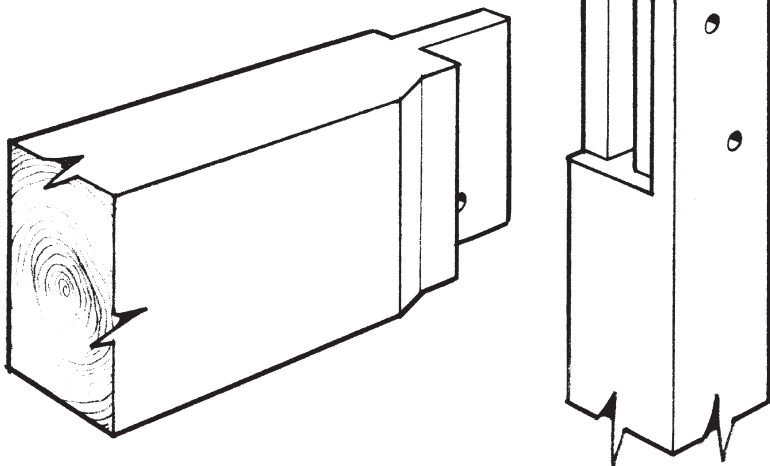

Fig. 6. In a blind-housed through mortise and tenon, the tie beam may be flush with one side or centered as shown. The uninterrupted long grain flanking the joint on the post resists breaking at the joint and mortise face splitout.

Fig. 7. Occasionally, the tie beam end is reduced in width at the housing. In some cases, it is done to square up an irregular or twisted beam end, in others to remove as little wood as possible from the post. Considerable wood can be removed from the side of the tie beam without creating a shear problem.



Paired Through Mortise and Tenon (Fig. 8). In frames with larger members, paired or twin tenons were occasionally used. Such a configuration will likely outperform a simple mortise and tenon, with reduced tendency for pin shear and mortise-face splitout. However, the advantage must be judged against the substantial additional work in the cutting of the joint. Paired tenons are sometimes found in mill structures, barns and large wooden machines like cider presses.

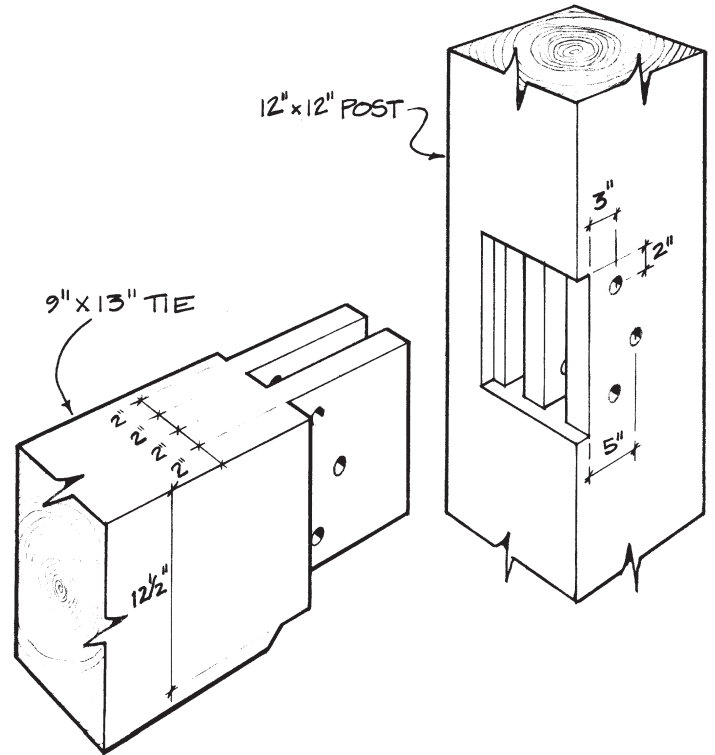
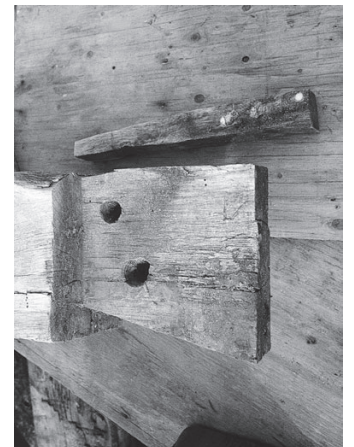

Fig. 8. Paired or twinned through mortise and tenon as found in a ca. 1840 barn in Middleburg, New York. The joint is housed flush with one side. As is typical of square rule structures, the tie beams are reduced to a consistent depth (here 12½ in.) at the joint. This rugged connection has well resisted the forces in the 50-ft.-wide barn.

The Wedged Dovetail Through Mortise and Tenon (Figs. 9 and 10). This joint is arguably the strongest to use in this particular application. It does not rely upon pins to resist tension. Instead, the bottom of the tenon is angled to form a half-dovetail as shown in the photo (from a late-18th-century barn, Great Barrington, Mass.). The mortise is extended above and also angled to permit a wedge to be inserted from the outside of the post. Though pins are used to bring the joint tight, the wedge-and-dovetail configuration does the work. If worked in green timber, shrinkage will allow some withdrawal. However, in many old frames with this joint, the connection is still snug. This is probably due to the speed at which timber ends dry. Much of the tenon's shrinkage has already occurred prior to assembly even though the interior of the timber a few feet away may still be saturated with water. Ordinarily it is difficult or impossible to drive the wedge further after the exterior skin is applied. Though this joint involves more work than the basic one, it is certainly worth the effort. It has been found in buildings of all nationalities and types and from every period.



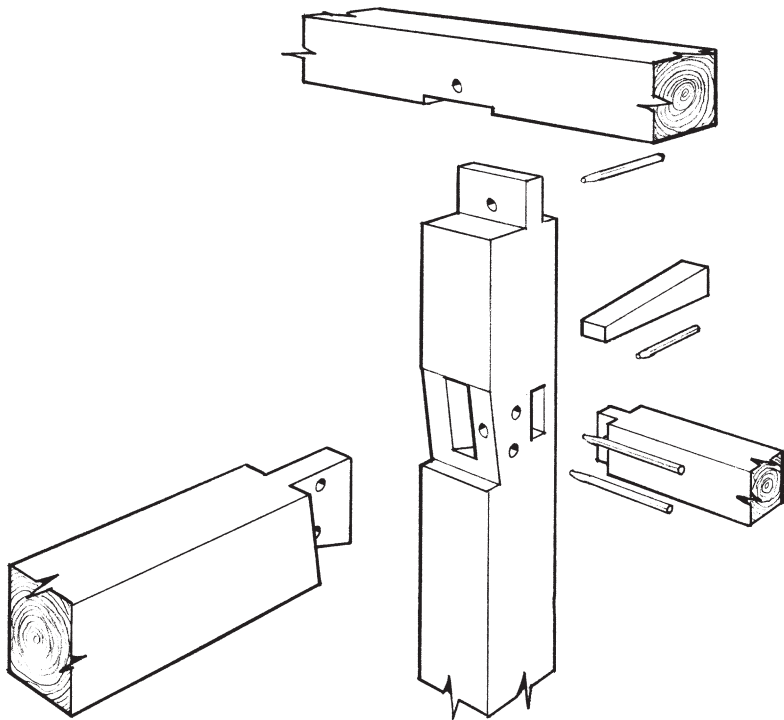
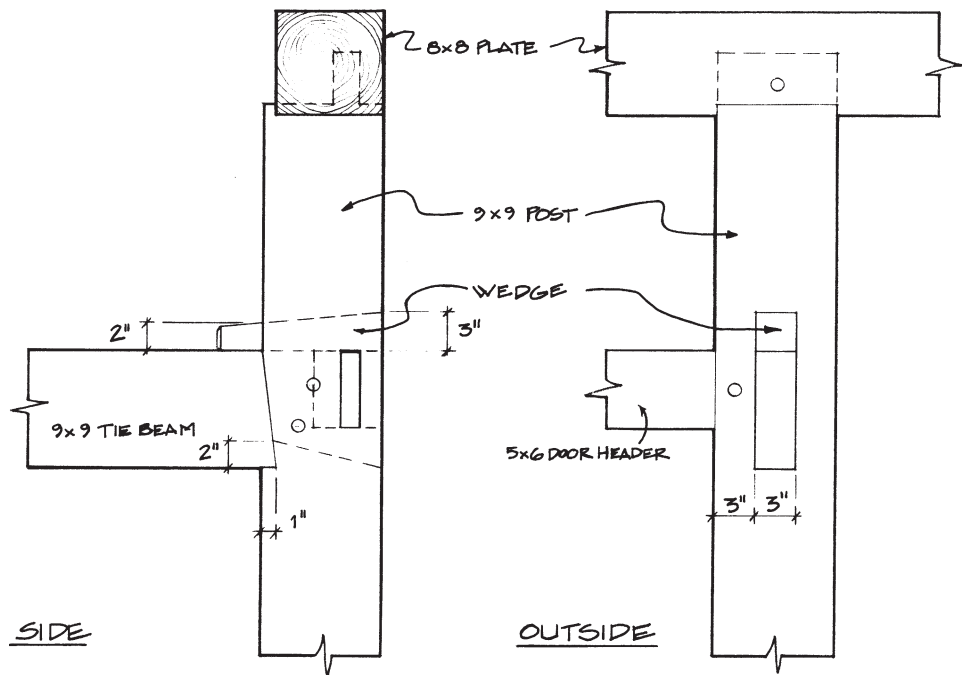
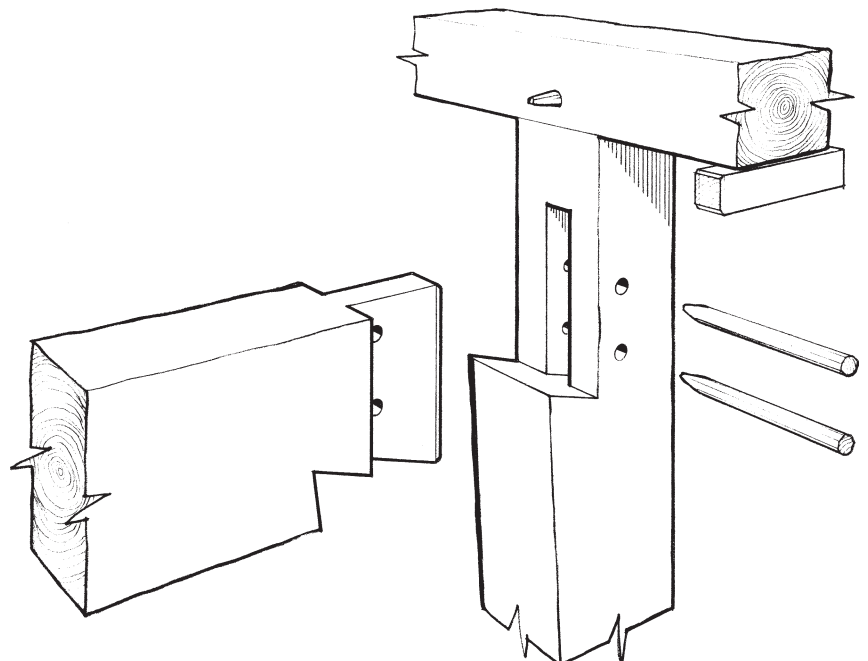
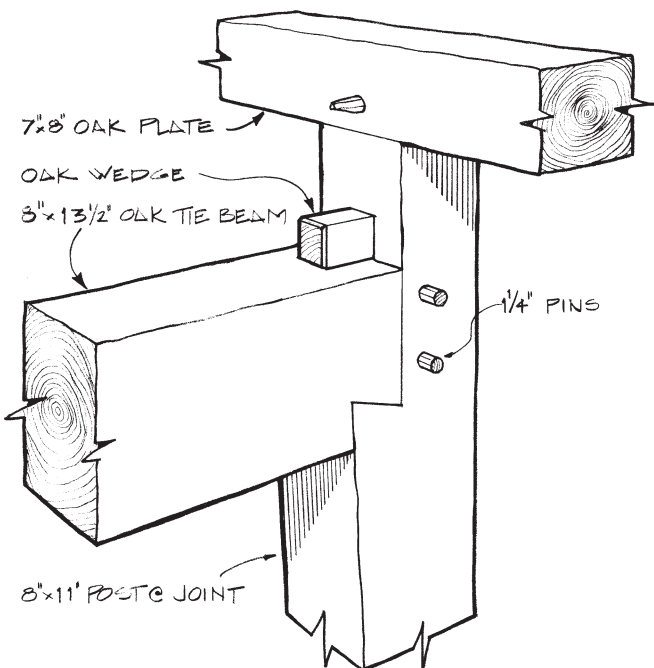

Fig. 9. Above, exploded view of the wedged dovetail through mortise and tenon in a late-1700s three-bay, 30x40-ft. English barn in Adams, Massachusetts, framed almost entirely of beech.

Fig. 10. At right, side and end views of the same joint with dimensions. A door header joins the post at the same height as the tie beam.



Figs. 11 and 12. Below and below right, assembled and exploded views of a wedged dovetail through mortise and tenon with dovetailed housing, as found in a 28x34-ft., three-bay side entrance barn in East Chatham, New York, probably dating from the second half of the 18th century. This unique joint has exceptional tensile strength.



The Through Mortise and Tenon with Dovetailed Shoulder (Figs. 11 and 12). A local (Columbia County, New York) variation of the wedged dovetail joint has the dovetail on the tenon continue into the housing which, because of the flare of the post, is about 3 in. deep. Only two buildings have been found with this joint. Judging by their location and similarities, they are likely the work of the same builder. The drawback to this joint would be the potential for the tie beam to fail in shear where it is notched to fit the housing. Apparently the load on the joint in this 28-ft.-wide barn is matched by the heavy oak tie beam, for nothing has failed in over 200 years.

The Kerf-Wedged Dovetail Through Mortise and Tenon (Fig. 13). A variation allows a basic tenon to become a full dovetail. Kerfs are sawn near the edges of the tenon and wedges are driven in to expand the tenon to fit a dovetail-shaped mortise. The kerfs are not parallel to the tenon edges, but angled away from the edge to avoid creating a splitting plane in the tie beam tenon when the edges of the tenon are bent away to follow the splay of the mortise ends. The advantage of this type over the wedged half-dovetail is that the tenon is not reduced in cross-section to create the dovetail. The disadvantage is that the angle of the dovetail must be shallow, and thus it will be affected relatively more by shrinkage of the tenon. In the illustrated example, the tenon flares only 1/4 in. on the top and bottom. After seasoning and shrinking of the members, the two pins may be carrying the entire load. It would seem that seasoned timber is necessary to use with such a subtle dovetail flare. I have found only one timber example, though the joint is common in furniture.

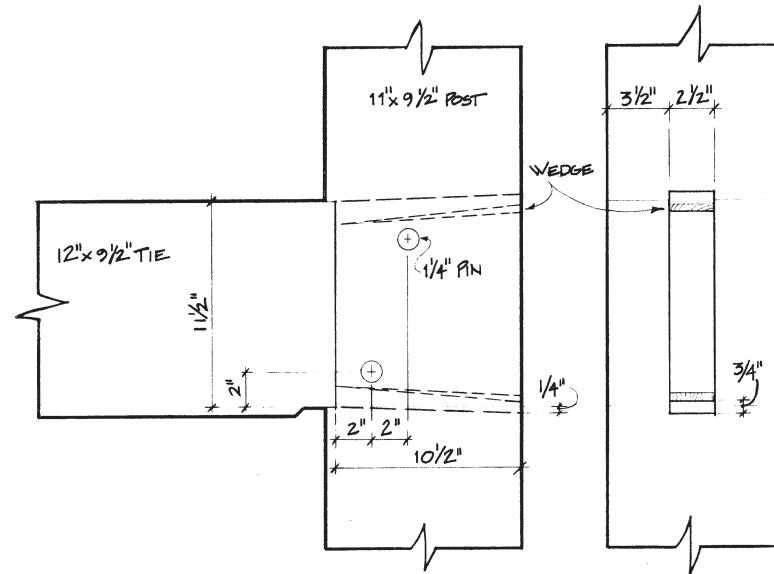

Fig. 13. This kerf-wedged dovetail through mortise and tenon joint is found in the upper floors (after 1810) of the Machine Shop at Hancock Shaker Village, Hancock, Massachusetts. It was used for both the tying joints and the queenpost trusses. This joint is much more common in furniture than in framing. Because of shrinkage in the height of the tenon, the wedges are loose, indicating that the pins are carrying the load.

Through Mortise and Extended Tenon (Figs. 14-16). When the building is aisled as in Dutch barns, the primary tying joints typically occur at the posts that flank the central aisle. These posts are joined by an *anchorbeam*, creating an H-shaped bent. The side aisles are treated as lean-tos and gain their strength from the H-bent. Since the tying joint is now interior, the tenon can be extended for additional strength without being exposed to the weather. (In Europe, such tenons are often exposed on the exterior of buildings.) Adding a foot or so of tenon prevents relish failure. By adding wedges through this tenon, all five potential modes of failure mentioned earlier are effectively eliminated save one: where the post breaks at the tying joint. The wedges can be driven additionally after the building is finished and the wood seasoned. The only disadvantage is that an additional 2 ft. or more of length are required on the anchorbeams, typically the largest timbers in a building. (Sections 12 by 24 in. are not uncommon.) The profile of the tenon varied with the builder.

This joint is synonymous with Dutch barn framing and can be found in hundreds of buildings throughout the area first settled by

the Dutch, primarily New York and New Jersey. However, it was not the only tying joint used in Dutch barns, nor was it used only in Dutch framing.

Necked Tying Joint (Fig. 17). Referred to in The Netherlands as a *Kopbalkgebint*, this joint also extends beyond the post for great strength. It may be used in non-aisled structures and still be protected from the weather as it can be tucked under an overhanging roof. The tie beam end resembles a head and neck. The tenon or neck fits in a slot cut in the top of the post to make a form of bridle joint. The post has paired tenons into the plate. This ingenious joint could hardly be improved upon. Its only disadvantage is that its location is fixed at just below the plate. It also requires posts wider than normal to accommodate the extra joinery. Only three American examples have been documented, two in Dutch barns in Blenheim and Schoharie, New York, the third in a three-bay "English" barn in Warren, Vermont (See TF 30).

—JACK A. SOBON

This unusual tenon profile appears on three Dutch barns in Coeymans, New York, and is likely the signature of a particular builder.



Photos Jack A. Sobon

Fig. 14. Below, a through mortise and extended tenon as found in an 18th-century 47x45-ft. Dutch barn in Root, New York. Two pins and a single wedge secure this housed version. Note that the pins are not equidistant from the top and bottom of the tenon. Perhaps this was done to reduce the tendency of the 24-in.-deep white pine anchor beam to lift off the shoulder as it shrank.

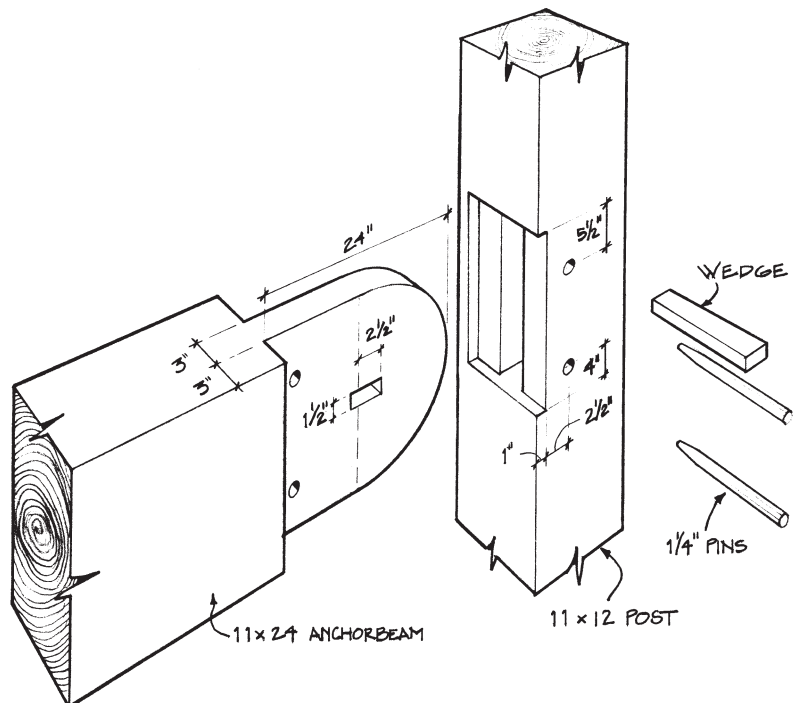

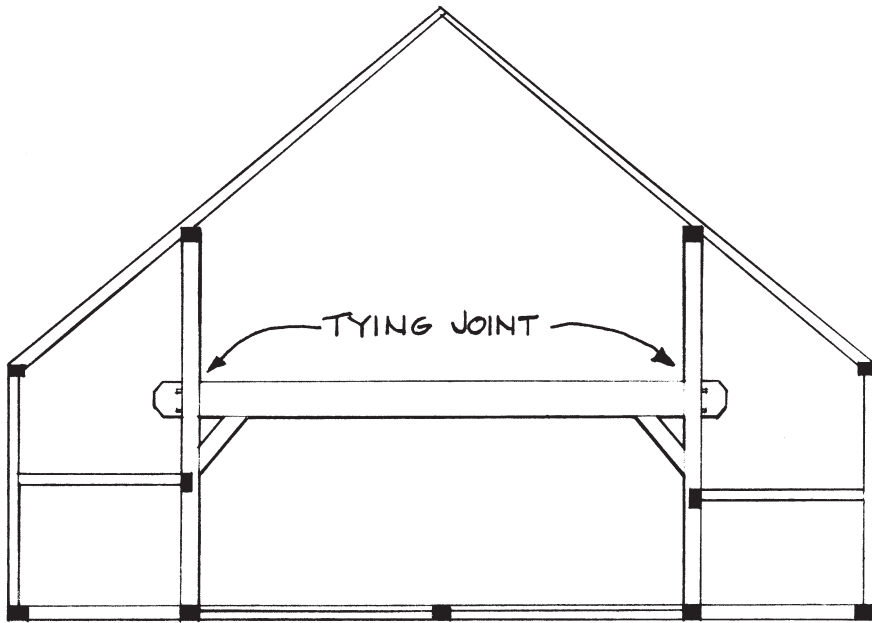

Fig. 15. The New World Dutch barn is an aisled building. The structural core is the H-shaped bent, each composed of aisle posts and an anchorbeam with heavy braces. Because the tying joint is interior, the tenon can be extended without being exposed to the weather.



Anchorbeam tenon ends from a pre-1820 Dutch barn taken down in Altamont, New York.

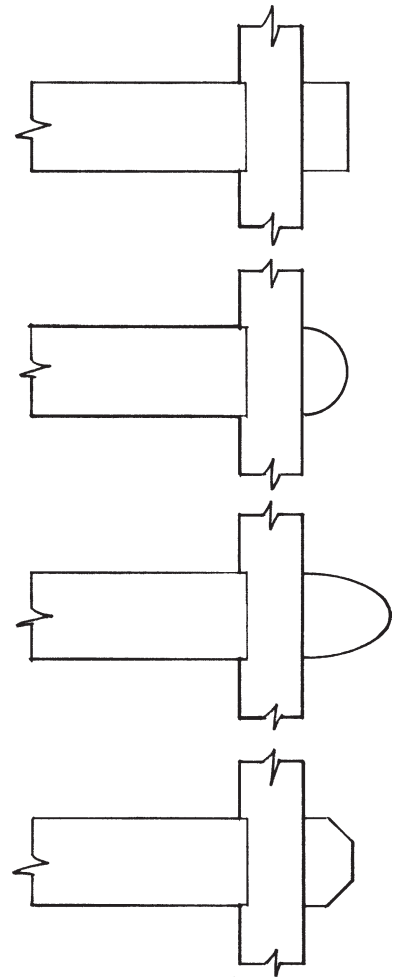

Fig. 16. Common variations on the shape of the protruding tenon. All versions have been found with two wedges, one wedge or no wedges.

Fig. 17. Assembled and exploded views of a necked tying joint in a ca. 1840, 30x40-ft. English barn in Warren, Vermont. The 9x9 tie beam has a 3-in.-thick neck secured as a normal through tenon with two 1-in. pins. The head protrudes 8 in. past the post. Two, 2-in.-thick tenons secure the post to the plate. This building was cut using the square rule system, and consequently the joint is housed into the plate. Roof thrust is additionally resisted by the plate bearing directly against the head of the tie beam.

