

*Los Angeles County
Museum of Art*

**US Department Of the Interior
National Park Service
National Center for
Preservation Technology and Training
Publication No. 1997-01**

A Review of the State of the Art of Laser Cleaning in Conservation

Margaret ABRAHAM, John TWILLEY

March 10, 1997

Conservation Research
The Los Angeles County Museum of Art
5905 Wilshire Blvd.
Los Angeles, CA 90036

Submitted to:

The National Center for Preservation Technology and Training
National Park Service, U.S. Department of the Interior
Natchitoches, Louisiana

Funding for this report was provided by the National Park Services National Center for Preservation Technology and Training NCPTT promotes and enhances the preservation of prehistoric and historic resources in the United States for present and future generations through the advancement and dissemination of preservation technology and training

TABLE OF CONTENTS

SUMMARY	3
INTRODUCTION	5
GENERAL INFORMATION ON LASERS	7
SPECIFICS OF LASERS FOR ART CONSERVATION	8
AN OVERVIEW OF PAST CONSERVATION PROJECTS USING LASERS	12
LABORATORIES CURRENTLY INVOLVED IN LASER CONSERVATION	14
THE STATUS OF CONTROLLED EXPERIMENTAL STUDIES	18
ANALYTICAL TECHNIQUES FOR UNDERSTANDING LASER CLEANING	22
PROPOSED CONSERVATION RESEARCH AND TRAINING	27
PROPOSED SYSTEMS FOR A LASER RESEARCH LABORATORY	29
ACKNOWLEDGEMENTS	31
BIBLIOGRAPHY	33
FIGURES	
BUDGET	

SUMMARY

Considerable interest, as well as concern, exists within the profession of art and artifacts Conservation regarding the potential improvements which may be brought about by the introduction of laser-based methods of cleaning. The following report was prepared for the purpose of proposing the format of a research center to be concerned with the development of laser cleaning technologies appropriate to the conservation of historically and artistically significant artifacts, including architectural materials. The current status of research being conducted on this subject in other parts of the world was assessed through a review of the published literature and a series of on-site discussions with other researchers during the period June-December, 1996.

The following conclusions were reached:

Very significant advances have been made in both the understanding, and practical application of laser cleaning by recent initiatives in Europe.

Large scale architectural cleaning projects, principally of stone, are being undertaken by both government and private sector groups in Europe. Commercial interests are developing in the field which are beginning to have an effect on the decision to use lasers or not.

Notwithstanding the above, the state of controlled experimentation in this area lags far behind its practical application.

Regional and national differences in the predominant categories of treatment needed, as well as differences in attitude toward the results desired, suggest that testing efforts should be broadened and that the U.S. conservation community would be best served by a facility in this country in which scientifically-based experimentation could be carried out.

It is proposed that such a facility should have the following characteristics in order to maximize the results obtained from the investment:

Laser cleaning research should be collaborative in nature, bringing together the disciplines of the conservator, the conservation scientist, the laser technologist and, as required, the analytical chemist, historian, archaeologist and architect.

A dedicated facility should be established under the auspices of an existing conservation laboratory in order to maximize the interaction of these disciplines.

Optimally, this laboratory would be equipped with both an infrared Nd-YAG laser and an excimer laser for ultraviolet work. Barring this, a higher powered Nd-YAG laser should be acquired to allow frequency multiplication to shorter wavelengths.

This laboratory should be staffed with at least one individual whose principle function it is to maintain the laser systems and to coordinate the program.

Institutional partners should be established who have committed to undertake specific roles in the analysis and testing of samples, consistent with their particular facilities and research strengths, in exchange for access to the laser facilities for their own cleaning investigations.

A series of specific research campaigns should be initiated (e.g. color reversion effects, pigment color changes, wavelength dependence of the cleaning, etc.)

Conservators both with and without institutional affiliation should be encouraged to devise investigations concerning specific cleaning problems that may be addressed by the laser facility. They should be given guidance in devising controlled experiments which would serve to advance understanding of the process in exchange for the opportunity to use the laser systems in dealing with problematic treatments to which it may be suited. In this way experience in the use of the technology would be disseminated at the same time that research is being conducted.

A policy for the publication, in refereed journals and symposia, of results should be established and supported.

INTRODUCTION

The following report attempts to describe the current state of the art in the use of lasers as a conservation tool for the cleaning of art and historical artifacts including architectural materials. To that end the authors have examined the various types of lasers available to conservators, the current techniques used in the process and the potential of the technology. Systematic, controlled research is needed across all areas of potential laser applications. A proposed structure and the laboratory requirements for one such project are detailed.

Lasers have been shown to be a promising alternative to more conventional cleaning techniques for certain discrete applications. Particularly in the case of stone, years of experience and limited laboratory experimentation have lent credence to the process. Stone exposed to environmental pollutants and an array of past conservation measures, including the application of consolidants, often exhibits a condition where in a hard crust of dirt and grime is well adhered to the fragile stone and a gypsum-containing patina. Traditional techniques of micro bead blasting, chemical poultices, and water washing have all failed, in certain critical cases, to protect the fragile surface. In a number of laboratories and on-site conservation projects the laser has yielded short term results which have been more satisfactory than traditional methods to the conservation staff in charge.

The majority of the work in the area of stone conservation has relied primarily on the empirical judgement of the conservator for the choice of instrument and operating conditions. Individual conservators have their own favorite laser types and power regimes. This is unsurprising given that no two objects are identical, having each been fabricated in a unique fashion or exposed to a unique series of events throughout its history. To a greater extent than with many alternate conservation methods laser cleaning depends upon controlling phenomena which are beyond sensory perception. The basic research needed to fully understand the parameters of laser effects should be made available to the conservation community at large. This research should further identify ideal laser types and processes for various conservation problems. By comparison with traditional stone cleaning techniques, the laser possesses uniquely consistent properties. A laser puts out a discreet amount of light, if properly designed and measured that amount can be expected to remain entirely consistent for long periods of time. A conservator should be able to rely on a laser to do the exact same job, on a given surface, every time.

The question arises, why then is there so much disagreement as to the value and uses of the various lasers available to conservators? The question is not unique to the conservation community, but has also arisen in the medical and materials processing fields in the recent past. The answer seems to lie in the lack of consistent and credible research into the design of the various lasers available and into the mechanisms by which they ablate or remove material. Because of the complexity of the laser systems, the conservation professionals charged with using the tool often have little knowledge of the many variables which they may encounter. Further, the economic realities of the world of conservation make it unlikely that the commercial laser manufacturers will ever find it profitable to undertake research into the use of lasers as a conservation tool on any significant scale. Unfortunately, without this type of research, the conservation community has advanced the art of laser cleaning very little over the years since its first experimental use.

Examples of how the current problem, of the dearth of adequate research into the field of lasers in art conservation, can be solved, are to be found in Europe. In recent years, through the efforts of government laboratories throughout the European Community, a number of small scale research projects have been initiated. In every case the project includes a collaboration between conservators, conservation scientists and scientists well acquainted with the physics of laser systems. Further, in every case the groups are combining fundamental research programs with programs to educate the local conservation community about the various properties of lasers as a tool.

The success of these groups can be measured not only in a small number of initial publications which do adequately address some of the parameters of laser systems or ablation mechanisms, but also in the increased use and acceptance of the tool in their respective communities. Only a few years ago the laser was a novelty item used only in stone conservation. In the last few years the tool's use has become wide spread, particularly in France, but also throughout England and Italy. Further, small scale conservation projects in Greece, Germany, Spain, The Netherlands, and Austria are underway.

It is also of interest to note the spread of the use of lasers to other areas of objects conservation as well as to paintings, paper and textile conservation. While in the early stages of development, these types of conservation projects are beginning to benefit from the research into laser-based cleaning.

In order for the technology to be utilized most effectively, the conservation community needs technical information, training and continued research to further its understanding of the processes involved. Moreover, the laser

optic communications, and as a pump source for YAG and other solid-state crystal lasers.

All lasers function on the twin principles of population inversion (wherein more electrons are out of the ground state orbital than are in the ground state for a given lasing medium) and feedback (wherein amplification of a specific wavelength is achieved in the lasing, or gain, medium through the use of mirrors at each end). This process produces a monochromatic light which in most cases is collimated. With the exception of the semiconductor laser, these light beams will not diverge into a larger more diffuse spot as they leave the laser.

THE SPECIFICS OF LASERS FOR ART CONSERVATION

The Nd-YAG Laser:

Because of its relatively low cost, high reliability, availability of moderate power ranges and a large number of other options, the YAG laser has been recognized as a good choice for art conservation purposes for a number of years, Figure 3. YAG laser systems are available today in the price range of \$20,000 to \$100,000 depending on the manufacturer, the power levels and the options desired. The compact size of solid state lasers makes them a good choice for both laboratory and field applications. They are relatively safe and reliable since they don't employ dangerous substances as a gain medium which must be disposed of.

In general, conservators use a pulsed laser, in which case the light is delivered in short bursts, as opposed to a continuous wave (CW) laser, in which case the light is delivered in a continuous beam. This pulsed operation allows for greater control, as each shot consists of a measurable and repeatable amount of energy applied to the cleaning process. The power source for the YAG lasers typically employed by conservators has been a flash lamp (the YAG does not directly convert electrical energy to photons so a very bright gas discharge lamp is used to inject energy into the YAG crystal). A semiconductor laser can also be used to power a YAG. This diode-pumped (DPSSL) option is more reliable than a flash lamp, which must be periodically changed. In addition, the semiconductor source of pump power is so much more efficient than the flash lamp that it generates significantly less heat and may soon eliminate the need for cooling the laser with recirculating water. Unfortunately this is still a very costly option and may not be affordable for most conservation applications for the foreseeable future.

With the exception of the pulsed operation and the flashlamp pump source there are few factors in choosing a YAG for conservation purposes which are clear cut. Some of these options include Q-switched verses long pulse mode, the use of non-linear frequency doubling crystals to change the wavelength of the laser from infrared to green, red, yellow or even ultraviolet, and the use of a flexible delivery system to bring the light to hard-to-reach spots. It is important to remember that the requisite power levels for a given job will depend not only on the object being cleaned, and the substance being removed, but also on whether any of the above mentioned options are employed.

The Q-switch is simply a device for removing, or blocking, the feedback mirror in the laser system in order to allow for more electrons to build up in the outer orbitals of the excited atoms. When the feedback loop is reintroduced the electrons cascade back to the ground state producing a short high fluence burst of light. In the Q-switch mode a laser will produce the same amount of light in a shorter pulse, which gives rise to an energy density which is higher, resulting in enhanced ablation. The first experiments with a Q-switched laser for conservation cleaning were carried out by Dr. John Asmus 25 years ago contrary to implication of the patent procured by Quantel within the EU. The Q-switch laser is ideal for removing thick encrustations on relatively robust (or non-absorbing) surfaces such as paint or encrustations on stone. In general, Q-switching will allow a conservator to clean dirt from these surfaces with a much lower power laser. Where it might require at least 1 Joule of light to efficiently clean a surface with a long pulse laser, often a 1/2 Joule laser will suffice in the Q-switch mode.

For more delicate jobs, for example soiling atop poorly-adhering gold leaf, the high energy of a Q-switch system may cause the substratum to ablate or damage the surface. In these instances it is advantageous to employ a laser operating in the long pulse mode. It is possible to purchase a single laser which operates in either the long pulse or Q-switch mode for a little higher cost. This may be a good option for labs which deal with a wide variety of objects or those interested in research. For a business where regular cleaning operations on the same types of objects occurs, the extra costs may be unwarranted.

For some applications wavelengths other than 1060nm may be more appropriate. Non-linear crystals are used to change the laser wavelength to other colors by frequency doubling. Typically the infrared YAG is doubled to green (532nm). The resulting visible laser light is diminished to somewhere

around 50% to 60% of the laser's power in the I.R. Using more or different doubling crystals one can achieve other colors of laser light but this will invariably result in large power losses. With a very powerful laser (> 1 Joule) and/or operation in the Q-switch mode this loss may be acceptable, otherwise the doubling crystal may render a system too weak to be effective. Of course, a laser which operates only in the doubled mode is typically rated on energy delivered out of the laser head and not out of the laser rod so the loss in power is accounted for in the published specifications. On the other hand a laser capable of operating in both the IR and doubled mode is significantly less powerful than its rating when operated in the doubled mode.

The primary advantage to using a green light laser is that its visibility allows one to observe the beam trajectory. While most systems have an inexpensive HeNe aiming laser (like those used as pointers at conferences) aligned to the YAG beam to have green light is somewhat safer for people who are using the laser. This cannot be taken to imply that a green laser may be operated without adequate eye protection (designed specifically for the wavelength being used), only that people will be able to see the danger from a distance.

The advantages, if any, to using a laser with several non-linear crystals may become most apparent when one is cleaning delicate or colored media. Since different colors of light are absorbed by different pigments or dyes, delicate paints or fabrics may be more or less susceptible to damage depending on the color of laser light used. This is an area where research is critically needed before the potential for the laser to replace conventional cleaning processes can be evaluated. Since development of the use of lasers for cleaning paint and fabric is still in the nascent stages, the added expense of a number of colors is only warranted in the case where the laser is to be used as a research and development tool.

The final option for YAG lasers is that of a beam delivery system. Much of the early conservation work done using lasers was accomplished by mounting the laser head (the part of the laser which houses the crystal and flash lamp, as distinguished from the power supply) on a tripod. The collimated laser beam exited the crystal and passed through a focusing lens. This lens enhances both the performance and safety of the laser. By moving into or away from the focal point one can vary the size of the area cleaned and the aggressiveness with which surface of the object is approached. In addition the divergence of the laser beam beyond the focal point will render it harmless at some distance determined by the power of the lens and the laser. Therefore the laser will be unable to cause eye damage outside the immediate area.

More recently laser systems with a fiber optic cable between the laser rod and the defocusing lens have been marketed to the conservation community. These cables allow for delivery of the light to a small hand-held wand or gun which is more easily manipulated than the laser head itself. Unfortunately the coupling of a fiber optic cable to the laser head is not a trivial matter and results in energy losses. The positioning of the cable is of the utmost importance in maintaining both the quality of the laser beam and the end of the fiber. Improper placement by even a few thousandths of an inch in any direction will result in the ablation of the end of the fiber which further lowers the power through the fiber. Therefore it is imperative that the manufacturer of the laser demonstrate that the fiber optic is easy to resurface and reinstall and that after each successive change of the fiber there is a mechanism for measuring the amount of laser light delivered through the fiber. Some sort of power meter to ensure that the light flux delivered through the fiber can still be accurately measured is a very good idea even for systems with no fiber coupling since a change in the laser's efficiency will effect the cleaning process. If the power level cannot be measured and optimized after a fiber is coupled to the laser head, then the cleaning process will need to be re-evaluated before the laser is turned to an object. In the case where the laser manufacturer does not provide tools and training for this type of maintenance the manufacturer should either guarantee the fiber optic connections soundness for a period of time or be willing to provide the service themselves. Baring this, a fiber optic attachment may be more trouble than it is worth.

A more practical beam delivery system is the articulated arm. In this scheme a series of mirrors reflect the beam down connected pipes. This system is both reliable and practical.

The Excimer Laser:

In addition to the YAG laser, more recently research has been conducted using the excimer laser as a tool for cleaning stone as well as for varnish removal on paintings. While this technique is still experimental, it does appear to be promising. In theory photons of higher energy (shorter wavelength) will clean the surface with a different mechanism. Instead of utilizing the heat generated by a long wavelength laser to, essentially, sublime the encrustation off of the artwork, or the compressive forces created by the expansion of heated gasses to mechanically eject layers of grime, the short UV wavelengths have a sufficiently high energy to cause the molecular bonds of the surface compounds to break. If sufficiently controlled, the excimer can remove the. surface of most materials one

molecular layer at a time. Recent advances in micromachining and the FDA's approval, while this report was in final draft, of the use of the excimer laser for re-sculpting the lens of the eye to permanently remove astigmatic and focal length distortions imply that excellent control of an excimer cleaning process should be possible.

While this is indeed a more controllable process from the standpoint of removal rates, it is not highly selective for a particular material type or color. The YAG laser light is absorbed in different quantities by different materials. Things which are dark in color often absorb better than those that are light. Thus the black pollution crust on a typical marble, containing gypsum and soot among other things, tends to absorb the light and is removed. The white marble will reflect most of the light, and will appear inert to the light within a given range of fluences. Thus, cleaning using IR wavelengths is somewhat self-limiting. The excimer generates a beam which is so energetic that it is absorbed by almost every material (with the exception of sapphire and fused quartz). Cessation of cleaning is not based on an inherent change in the material exposed to the beam. Instead, it is primarily up to the discretion of the conservator using the equipment.

A final consideration for the purchaser of a laser is the pulse rate (the number of shots delivered in a given time, usually measured in Hz) requirement for his application, the fluence (photons/unit area), the availability of interchangeable defocusing lenses, the ergonomics of any particular system, power requirements for operating the laser in various environments, and the safety requirements for his application (number of safety glasses, emergency shut off switches and light blocks such as curtains for the work area).

AN OVERVIEW OF PAST CONSERVATION PROJECTS USING LASERS

Although a large number of critical, early experiments in conservation using lasers were carried out in the late 1970's and early 1980's in both Venice, Italy, and San Diego, California, by John Asmus (Asmus, 1986), the first major projects which relied principally upon laser divestment began in the late 1980s. One of these was the cleaning of the portal sculptures of the Cathedral of Cremona in 1989, Figures 4 & 5. The work was carried out by Meg Abraham, under the direction of architect Giancarlo Calcagno and physicist John Asmus. The project involved the removal of deposits from the calcitic marble statues by Willigelmo (12th century) in the portal of the cathedral. The laser head was manufactured by Apollo Laser and was a normal mode YAG triggered by a foot pedal with very low repetition rates of about 1 Hz. Progress was slow.

In the time since that first project, the state of laser cleaning has evolved rapidly. With current lasers, operating at approximately 30 Hz, projects have been completed at such important sites as Notre Dame in Paris and the Cathedral at Amiens. At both these sites large areas of stone (the portal of La Mere Dieu at Amiens) have been cleaned using laser divestment. The conservators involved believe that the badly damaged stone (Figure 6) would have experienced greater losses using the traditional methods of bead blasting, and chemical poultices.

Of equal interest is the extension of the use of the current laser techniques into the objects conservation laboratory. Until recently, the YAG laser was used only in the limited regime of divestment of black sulfate crusts, commonly found on stone exposed to the outdoor city environment. Recently several important projects have been undertaken which employ the laser to clean additional compounds from the sculpture or to clean works in some other media than stone. An example of the former is the previously mentioned marble panels from the Donatello Pulpit from the Prato Cathedral which was coated with a number of silicates and plastics during past restorations. Without the use of the YAG laser, the quality of the results of cleaning this important work would have been much diminished according to the participants.

The use of the laser on alternative materials has been pioneered by J. H. Larson and his colleagues at the National Museums and Galleries on Merseyside. While continuing to work on monumental stone, such as the life-size 19th century carrara marble statue of William Huskisson and a number of classical marbles, the group has expanded their research to include work on a variety of materials. Perhaps the most impressive object they have cleaned using lasers is the life-size aluminum Eros which now stands inside the new conservation visitor center at the museum. They have also demonstrated good results on such hard-to-clean materials as terracotta, bone, ivory, and stucco (Larson, 1995).

There is a narrower range of experiences using excimer lasers in actual conservation projects. The FORTH-IESL group (under the direction of Dr. C. Fotakis), in collaboration with the National Gallery of Athens (Dr. M. Doulgeridis, Sr. Paintings Conservator) have demonstrated the use of excimers to clean the varnish and overpaint from an 18th century icon of St. Demetrius (Hontzopoulos, 1992). They continue to work on using the technique to clean glass, paper and paintings. Recently they began collaborating with a group from the Netherlands on a project to clean wall murals.

While these types of results were predicted by Asmus based upon limited laboratory experiments on a variety of objects, the rapid increase in the use of the laser for cleaning purposes across Europe is a clear indication of its potential as a tool and its growing acceptance in the conservation community at large. One can only expect that with improved understanding of the current laser systems and research into the mechanisms by which they exert their effects that the laser will become an increasingly important tool. Further, one should expect that other systems, such as free electron lasers and dye lasers may add to the repertoire of laser cleaning tools available to conservators of successive generations since they are increasingly being employed in industrial and medical applications requiring comparable degrees of control and predictability. As this report entered its final draft the U.S. Food and Drug Administration approved clinical use of the excimer laser for the permanent correction of astigmatic distortions in the eye, an operation requiring the removal of a precisely known, and varying thickness of tissue by laser ablation.

LABORATORIES CURRENTLY INVOLVED IN RESEARCH INTO LASER CONSERVATION AND ASSOCIATED COMMERCIAL DEVELOPERS

There are a number of laboratories across Europe, which are currently involved in research concerning lasers for art conservation. The most active of these laboratories include those in Greece, Italy, France and England. In each case, a particular research philosophy has developed, with specific aims and research strategies. It is useful to consider these philosophies when discussing their work.

The research group at the Foundation for Research and Technology Hellas in Heraklion has been working with both YAG and excimer lasers for conservation purposes. A part of the University of Crete, the group is headed by Dr. C. Fotakis, and the laser research team is lead by Dr. V. Zafiropulos. Their emphasis has been on research and development of diagnostic techniques for understanding ablation mechanisms and ablation products. They are very involved in quantifying the process of ablation for each laser and understanding the mechanisms. They are, conversely, less interested in purely empirical studies of particular applications of the laser conservation process.

To that end they have used the following diagnostic tests: XRD to detect anhydrite resulting from thermal dehydration of the gypsum layer, FTIR to detect calcite and gypsum, X-ray spectrometry for elemental analysis, time of-flight mass spectroscopy (which can reveal isotopic ratios S^{34}/S^{37} potentially useful in dating), and Gas Chromatography-Mass Spectrometry

(GCMS) to check for oxidation of oleic acid or for fatty acids generally. In addition, they have developed the techniques of Light Induced Breakdown Spectroscopy (LIBS) and Light Induced Fluorescence (LIF) to detect changes in the free radicals being produced during ablation and in the composition of the remaining substrate during the cleaning process.

The FORTH research team has used both YAG (IR= 1064 nm) and KrF excimer (UV=248nm at about 250 millijoules of energy) for ablation studies. They are of the opinion that ablation results from three primary mechanisms: Thermal, photochemical and photomechanical. Further they have come to the conclusion that the primary mechanisms for ablation using a YAG are thermal and photomechanical while the mechanisms for ablation using excimer are photochemical and photomechanical. With short pulses and high absorption rates, the thermal effect produced by the excimer is small (diffusion length = 80-100 nm for a 20 nanosecond pulse in dammar varnish) and the etch depth is greater than the depth of the thermal effects. Therefore there should be no heating of surfaces or recrystallization effects (which may cause, for example, some yellowing of a stone surface) using an excimer, they argue.

The scientists at FORTH have been working in consort with Michalis Doulgeridis (head of the Department of Artistic Conservation and Restoration of Works of Art at the National Gallery, Alexander Soutzou Museum), using the excimer to remove both overpaint and varnish from tempera paintings on wood (Greek icons). The technique seems to be best suited to works with a planer paint surface and uniform layers of varnish or overpaint. They feel that the excimers were also very useful in removing glue, and cleaning and sterilizing the backs of canvases. In their view excimers are better at removing biological material from stone and for leaving the stone with a white surface (this may result from the more extensive removal of the gypsum "patina" beneath the black crust by the excimer).

The FORTH group is offering their services to help to establish labs for lasers in conservation by building work stations for cleaning and diagnostics, training personnel, and prototyping imaging equipment (They have also developed a camera with four spectral imaging ranges: false color infrared, visible, UV, and IR). Currently they are consulting in the establishment of a laboratory for laser conservation with the SOLON group at University of Twente in the Netherlands.

The Italians have had many years of experience with laser cleaning in conservation in several groups. Although each group has a slightly different approach to the problems involved in laser cleaning, the Italians have, with

the exception of some work using excimers on stained glass, concentrated their research efforts on the YAG laser systems and the cleaning of stone.

At Quanta Systems, in Milan, they are marketing a laser for art conservation called "Palladio" which sells for approximately \$60,000. The laser runs in normal or Q-switch mode with 100 microseconds and 6 microseconds pulsewidths, respectively. The rep rate is 1-20 Hz and the laser can be frequency doubled (550 mJ @1064nm or 250 mJ @532nm) at an added cost. The beam is delivered through an articulated arm and the hand piece has a proximity sensor for safety. They are beginning to design diagnostics for there system (they mentioned incorporating XRF) but are not yet able to deliver any diagnostics.

At the Istituto di Elettronica Quantistica in Florence, Drs. Salimbeni and Pini have done some work developing a system to measure the size of the plasma plume ejected from the stone surface after ablation. By shining a coherent low-power laser beam (HeNe) parallel to the surface being ablated and into a CCD camera they could see interference fringes and scatter of the laser light after the ablation pulse. In this manner a sense of the size of the "recoil" pulse can be gained. They have also done some work with mid-length pulses (30-50 microseconds) and have had some success using excimers to clean stain glass.

At the Opificio delle Pictre Dure e Laboratori di Restauro Firenze, they have taken the approach that YAG laser cleaning is now a standard tool for the cleaning of stone, although they still recognize the value of the traditional methods of bead blasting and of chemical cleaning. Dr. Matteini, a chemist at the Opificio, has expressed the organization's concern that the tool's long term effects have not been adequately studied, particularly with regards to the stability of the gypsum patina left intact by YAG cleaning. Because of Dr. Matteini's expressed concern over the solubility of the gypsum layer left by laser cleaning, he suggested that further study of the stability of laser cleaned stone would be useful to them and that they prefer to use the technique of laser cleaning on stone which is in a dry or protected environment.

Nonetheless, they are supporting work on a Donatello pulpit which is a particularly interesting case. It had been restored in the past with successive applications of acrylic, fluosilicate, and silicone polymer. In this instance, neither bead blasting or poultices had been effective in removing the resulting gummy mess. A private conservator, Alberto Casciani, is having good success using a YAG laser to clean the stone.

Finally, a number of private conservators, including architect Giancarlo Calcagnio, are now routinely using the YAG as one of their tools for cleaning stone (Figure 7).

Like the Italians, the French have concentrated their efforts on using the YAG to clean stone. At the Laboratoire De Recherche Des Monuments Historiques (LRMH), in Champ-Sur-Marne, Genevieve Oriol' and Véronique Vergès-Belmin have cooperated with Christopher Weeks, of the GROUZ SARL (a private conservation firm) to study the use of YAG in large scale stone conservation projects. Some of the structures which this group has cleaned, in part using lasers, are: the basilica of Notre-Dame at Paray-le Monial, Cathédrale Saint-André in Bordeaux, Cathédrale Saint-Etienne also in Bordeaux, Cathedrale of Notre-Dam in Rouen, the Basilique of Saint-Denis, the church of Saint-Maurice at Lille, the church of Saint-Nicolas at Toulouse, the church abbatiale in Saint-Gilles-du-Gard, and the Cathédrale at Amiene. Further conservation projects are continuing across France. The researchers at the LRMH feel that the stability of the gypsum layer is not as large a problem as do the Italian researchers (and to some extent their Greek counterparts). In their opinion, although other cleaning methods often strip this layer, it may contain important information and be of artistic value. They feel that to leave behind the gypsum layer and allow it to weather naturally is the most prudent course. They have also done some thin sectioning of stone and shown that the gypsum layers may form in strata beneath the surviving stone surface, making it difficult to remove all the gypsum, without removing some of the stone (Oriol, 1995, part 2).

In addition to the above mentioned groups, two French companies are in the business of selling lasers for stone conservation, Both Quantel, and BMI have YAG products, designed for conservation purposes, operating in the Q-switch regime at 1064 nm, which sell for around \$90,000.00.

Some of the most persistent effort on conservation development of the YAG laser has been conducted in England. At the National Museums and Galleries on Merseyside conservator John H. Larson has a long-running research program using YAG lasers as a tool for cleaning objects. His staff includes two laser physicists who build and maintain the lasers as well as conducting classes on lasers as a conservation tool. The doctoral research subject of his colleague, Dr. Martin Cooper, was the use of the laser for conservation cleaning.

The group has not limited their work to the cleaning of stone. In fact Larson feels that he has had tremendous success in cleaning wood, plaster, basketry, stucco, terracotta, bone, ivory, and aluminum. It is apparent that

the YAG laser is not simply a research tool at the museum, but is an important tool in everyday objects conservation.

In addition to the museum, the University of Liverpool is conducting research into the use of different YAG wavelengths (generated using different non-linear processes to deliver the second, third and fourth harmonics) to preferentially clean various paint pigments. Under the direction of Dr. Ken Watkins in the Department of Mechanical Engineering, two graduate students are doing doctoral research on the subject.

The British company which has provided the lasers used in Larson's group, Lynton Lasers is selling a Q-switched YAG system (the Phoenix) for conservation purposes (price is about \$65,000 and the system operates in the IR only). The energy output is 300mJ with a pulsewidth which is unknown to the authors and a repetition rate of 10Hz.

Based on the amount of research activity involving the use of lasers in art conservation, it is apparent that the YAG is rapidly becoming entrenched as an important option for object conservators. Further, the excimer laser has the clear potential to expand the use of lasers into the realm of conservation of paintings, paper, glass and textiles.

THE STATUS OF CONTROLLED EXPERIMENTAL STUDIES ON LASER CLEANING EFFECTS IN CONSERVATION

Until very recently nearly all findings available in the conservation literature for laser cleaning of objects were empirical and applicable only to the individual project being discussed. This is a natural consequence of the fact that much of the work, after the initial experiments conducted by Asmus, was demonstrative in nature rather than structured around controlled experimentation. Individual objects were chosen, by conservators, as examples which might be cleaned by laser and the task was completed and reported on. While these demonstrations were of great importance in convincing the conservation community of the possibilities of the tool, the publications did little to advance a broad theory as to how the mechanisms of ablation work on different materials. Further, the lack of scientific reporting by a number of conservators involved in the demonstrations may have led to some misconceptions about the best ways of comparing various results.

Many of the past publications on laser ablation, using YAG, reported the power/ intensity of the laser in watts or joules and recorded whether the laser was running in long pulse or Q-switch mode. They usually included

some observations concerning the qualitative results obtained, and occasionally a qualitative diagnostic aid such as a scanning electron micrograph was included.

Unfortunately this type of literature largely under-reports the scientific information needed to understand both the power of the laser light directed on the surface of the art and the mechanism by which material is being ablated. As previously noted, the light coming from a laser can be delivered in long or short pulses. This is an over simplification of the technology. A normal mode laser usually operates with pulses from 0.1 to 1 millisecond and can be made to operate with pulses as short as 20 microseconds (.02 millisecond). A long pulse laser with 1 joule of peak power operating with a 1 millisecond pulse distributes the energy over a much longer period of time, creating less plasma and potentially more heat than a shorter pulse, normal mode laser. The initial ablation depth for this laser will probably be less, and there will be a broader regime of powers in which one can work. There is also more likelihood of damage to the substrate due to heating. The same phenomenon can be seen in the Q-switch mode laser which can generate pulses varying from 5-10 nanoseconds. In this case the intensity of light incident on a work of art in a given time can double because the time is halved.

Another variable seldom reported is the spot size. Typically the spot coming from the laser is dependent in large part upon the YAG rod used. That spot is almost never left collimated. Instead it is usually focused down to a "waist" or smaller spot. If the object being cleaned is placed at the waist, or focal point, then the flux incident on the object is more intense than that coming from the laser as reported by the manufacture. As the object is moved from the focal plane closer to the lens, the light intensity approaches that reported by the manufacture. As the object is moved from the focal plane away from the lens the light diminishes from maximum intensity to zero intensity. The positional sensitivity of this effect is dependent on the power of the lens so that one cannot infer the power density without this information. Without careful calculations or advanced measurement techniques one cannot be certain of the spot size nor determine the intensity of the incident light.

Another problem encountered in the literature derives from the manner in which manufacturers report power levels. Some report peak powers (that is the maximum power reached during a light pulse), others report average powers (the power averaged over the duration of the pulse). Further, their definition of pulse length may vary somewhat and is difficult to measure without extensive instrumentation.

Finally, the beam quality is a factor frequently ignored in these reports. An ideal beam would be uniform over the round spot and propagate in a perfectly planer wave front. Unfortunately, most 'AG lasers deliver a round beam with more and less powerful regions, Figure 8. Furthermore, the light wave may propagate from the laser in a concave or convex wave front. As the laser 'AG rod heats up in use, beam inhomogeneities may change. This effect is most clearly seen as a tendency for the beam to steer, or drift in position during the first few seconds of operation, as the rod comes to equilibrium. Variation in operating conditions or in the performance of the cooling system affect the beam quality.

The potential value of the laser as an art conservation tool lies in the fact that it is possible to control all of these parameters to a very high degree. The fact that very good cleaning performance has been achieved in individual cases without such controls is due to the repeatability of individual laser systems. As practicing conservators have noted, the skill of the conservator and his familiarity with the instrument at hand are very important factors in this case. Unfortunately, this skill cannot easily be translated to other conservators, nor can his skill with one machine be automatically translated to another machine. Only by careful experimentation and varying the parameters of the YAG laser can the conservator maximize the usefulness of the tool, convey his results or translate them to another laser system. Clearly this needs to be understood and stated in publications. Since these factors have not been adequately addressed in most publications, it is of little use to make intercomparisons among past research projects using YAG lasers.

The task of comparing conservation results achieved with excimer lasers is somewhat less complex. This is in part due to the fact that, until now, most of the relevant research has been conducted by a small group of scientists and conservators using the same lab and lasers. Further, the beam parameters of the excimer (Figure 9) are somewhat less complex than those of the 'AG due, in part, to the rapid equilibration of the gas-phase lasing medium. Unfortunately, if the parameters of excimer performance are not fully understood, measured and reported by researchers who will doubtless advance the state of the art in excimer conservation, the same pattern of difficulty in comparison and transference of results is likely to be repeated.

For this reason, it is gratifying to see that some of the most recent publications on laser ablation using both excimer and YAG are beginning to address the means by which common discussion about lasers and ablation mechanisms may take place. Specifically, the investigators at the Istituto di Elettronica Quantistica C.N.R. (Salimbeni, et. al.) working in conjunction with the Opeficio della Pietra Dura are beginning to look at pulse length

verses plasma formation and acoustic wave formation. The LRMH in France is looking at the quality of the patina left after irradiation under different conditions and the FORTH group in Greece is looking at various ways to measure ablation products and ablation depth. Finally, Dr. Watkins (University of Liverpool, in conjunction with Larson's laboratory) is working on ablation mechanisms under different wavelength conditions. Some of this work was initially presented at the LACONA conference in Crete in 1995. Unfortunately much of it is still not available except by contacting the laboratories directly. Until a more rigorous set of experiments is published it is of little use to spend time on the examination of past conservation projects. Instead, current efforts need to be concentrated in developing standards for the reporting of results and on implementing controlled experimentation based upon analytical testing of the surfaces before and after cleaning by both the laser and by conventional techniques.

It is worth emphasizing that controlled experimentation into the effects of cleaning by conventional methods is often lacking. Faith in the absence of detrimental effects during cleaning by conventional methods (which have not always been subjected to the level of scrutiny directed toward laser cleaning) sometimes leads to oversight of their deficiencies. Unfortunately, the introduction of a new method such as laser cleaning may be impeded when careful study documents ill-defined "changes" to the substrate if widespread, but perhaps unfounded, faith exists in the absence of detrimental effects during cleaning by conventional methods. In other words, to properly document the effects of laser cleaning it is necessary to compare its effects not only with controls but with alternative conventional procedures for achieving the same result. In short, little quality research has been conducted in the field prior to the last few years.

Outside the field of conservation the literature describes tremendous advances in the understanding of laser ablation processes in recent years. These have resulted from research in two primary areas, one of which is concerned with the control of the process of material removal and one which is concerned with control of the process of material redeposition. Driven by recognition of the potential for ultraminiaturized mechanical devices in medicine, the field of micromachining is attempting, with considerable success, to form microscopic motors and pumps from components machined out of monolithic materials such as silicon through the use of laser ablation. The tremendous interest in the construction of practical devices from high-temperature superconductor materials has led to the extensive use of laser ablation/redeposition as a technique for their formation.

Manufacturing operations of extraordinary delicacy and selectivity have been facilitated by the fact that, unlike conservation subjects, the materials

involved are well-characterized, uniform materials. This has allowed much to be learned about the mechanisms involved through methods such as time-of-flight mass spectrometry, Auger spectroscopy and so on. While not directly transferable to the conservation world of complex, stratified surfaces, semi-volatile phases and unique, one-of-a-kind objects, conservation can only benefit by being informed of progress in these other areas. In particular, advances there should yield better methods for “process diagnostic” aids and, potentially, for feedback control of the cleaning process.

ANALYTICAL TECHNIQUES FOR UNDERSTANDING LASER CLEANING

The central requirement of a laboratory engaged in conservation research on laser cleaning is access to analytical instrumentation by a scientific staff with experience in the study of the materials of the artist and craftsman, It is critical to know the composition and compositional variation of the material being removed and the substrate beneath in order to make comparisons of cleaning effects. The types of instrumentation required vary from those which allow the quantification of appearance factors such as color, gloss, and translucency to those capable of disclosing structural and compositional variation on a microscopic and submicroscopic scale.

A summary of the techniques which we propose to employ follows:

Fourier Transform Infrared Spectroscopy

Within this technique there are many methods of sample preparation and presentation which are applicable to different situations. These include techniques for analysis of surfaces in-situ in a reflection mode and those requiring the removal of a sample for analysis in transmission. All are informative as to the chemical bonding and functionality involved in the analyte and relatively blind to elemental composition except as it can be inferred from the former. Analysis of organics is particularly facilitated but a great many inorganics and minerals can also be studied by the technique.

Micro-FTIR: Samples of as little as 30 microns in diameter removed from objects before and after cleaning may be rapidly identified or categorized for further study by a microscope FTIR. Depth resolution is related to the skill of the investigator in extracting material. Common surface alteration minerals on weathered stone may often be identified more rapidly by FTIR than by X-ray diffraction. For slightly larger samples, increased information from a broader spectral range may be obtained by the use of beam condenser techniques.

ATR (Attenuated Total Reflectance): The surface chemistry of planer solids, whether transparent or opaque, may be studied to the exclusion of the bulk composition below by this method. This is expected to be particularly useful in evaluation of the surface effects of laser cleaning.

DRIFT (Diffuse Reflectance I.R. Spectroscopy): The surface chemistry of rough, highly light-scattering material including loose powders may be investigated by this technique. This is expected to be particularly useful in evaluation of the surface effects of laser cleaning.

Functional Group Mapping (I.R. Milliprobe): Suitably designed instruments can provide areal maps of the relative concentrations of designated functional groups. Such instruments are of limited availability but would be particularly useful in studying re-deposition, shot-boundary effects and overlap problems on suitable substrates. This is likely to be more applicable to mock-up samples than to art object surfaces.

Scanning Electron Microscopy (/X-ray Spectrometry)

SEM examination is essential for study of both the surface morphology before and after cleaning and for studying three dimensional surface stratigraphy in suitably prepared cross sections and fracture sections. It is key to understanding micromorphological changes which may not be identifiable on the basis of composition. For example, from a related area of inquiry it has been observed that gas plasma reduction of silver tarnish can result in effective reduction of tarnish which may, however, result in a visually undesirable haze due to the physical form of the resulting silver which causes light scattering. Incipient vitrification and other thermal effects such as microfracturing or recrystallization may be recognized from SEM micromorphology. By standard methods of surface replication via cast polymer films this capability may be extended to objects which cannot actually be sampled or placed inside the SEM.

Coupled with the elemental analysis capabilities of an energy or wavelength dispersive X-ray spectrometer the SEM can provide critical evidence for the identification of individual particulates or microstrata which are too small for extraction and identification by other means. For suitably prepared samples quantitative analysis may be desirable in some cases.

Scanning Transmission Electron Microscopy and Electron Diffraction

Though time-consuming in terms of sample preparation, these two techniques can provide phase identification on a scale too small for approach by other methods. Ion-milling allows the reduction of layered structures which are too thin, too well attached, or too malleable to remove for analysis and which are not readily distinguishable in cross section.

Colorimetry

Optical colorimetry allows standardized measurement of color which is essential for the investigation both of the effects of cleaning and of potential reversion phenomena affecting the color subsequent to cleaning.

X-ray Diffraction

XRD is essential for phase identification of the materials to be removed and of the resulting phases on the cleaned surface if they are sufficiently thick. Using Gandolfi camera techniques it is possible to provide this information for quantities of materials as small as 30 microns in diameter. Samples removed from strata exposed in cross section can readily be identified by this technique if the material is sufficiently thick. However, it is expected that any conversion products left after laser cleaning would be too thin for such a technique if control of the laser is adequate to avoid thermal decomposition effects.

X-ray Photoelectron Spectroscopy (XPS or ESCA):

This technique allows the determination of the elemental species and their states of chemical combination within the first few atomic layers of the surface of virtually any type of material including non-electrically conductive materials (a limitation of Auger spectrometry) and loose powders. Although the thickness of the zone probed by XPS is too thin to be of importance in evaluating the typical surfaces to be cleaned by use of the laser in conservation, this technique holds some promise for understanding the state in which the freshly cleaned surface is left and the first stages of its subsequent interaction with the ambient environment. It also holds considerable potential for the investigation of redeposition phenomena and the identification of material which is too finely divided to be recognized during SEM examination, particularly in microprobe instruments with limited resolution and stage flexibility. Due to the dependence of the spectra upon the outer electron configuration of the elements analyzed, this

technique may be helpful in understanding color changes associated with the change of oxidation state of various polyvalent metals (e.g. iron). Another area of potential application lies in the characterization of pigment particle surfaces. It has frequently been noted that discoloration of certain susceptible pigments such as lead white and vermilion is confined to a surface which is too thin to result in diagnostic changes to the X-ray diffraction pattern or infrared spectrum. XPS may provide an analytical technique for following problems of laser-induced pigment discoloration.

Historically the area resolution of XPS instruments has been limited but recent models achieve results from areas as small as a few tens of microns. Its sensitivity for minor elements is generally good. The principle limitation of the use of this technique is the high hourly cost of commercial laboratories and the limited non-commercial availability of the technique. The alternatives available to a government-funded project should be explored such as the availability, at nominal rates, of government-supported facilities of this kind.

Optical Microscopy:

A broad spectrum of optical microscopy techniques may be employed. Chief among these is the optical inspection of paint and metallographic cross sections and petrographic, and ceramic thin sections before and after laser cleaning. The staff of the LACMA Conservation Center have pioneered methods for such structural study of difficult materials including the preservation of soluble compounds and organic materials in friable stone and the simultaneous cross sectional study of soft, brittle and extremely hard materials in the same sample (e.g. lead solder, intermetallic compounds and sintered alumina). Polarized light and U.V. fluorescence microscopy may be usefully employed as well.

Secondary Ion Mass Spectrometry (SIMS):

SIMS is a technique for depth profiling of the uncleaned and cleaned surfaces which can provide useful information about stratigraphic relations, thermal effects such as partial dehydration due to localized heating, and elemental profiles. Most instruments contain the provision for ion-milling of the surface in between spectrum acquisitions so that analyses at a series of stepped depths can cover a range much in excess of the analytical depth obtained in any one run.

Auger Spectroscopy:

This technique is applicable only to electrically conductive surfaces and as such would be potentially useful only for metallic surfaces. Nonetheless it could prove useful in the investigation of tarnished metals and re-tarnishing phenomena. The specificity of the bonding information which can be derived from the shape of the spectra is more limited than that provided by XPS but the instruments are somewhat more readily available. Cost factors would limit the application of this technique unless a collaborative arrangement could be developed with such a laboratory.

Laser Induced Breakdown Spectroscopy (LIBS) and Light Induced Fluorescence (LIF):

Both the LIBS, and the LIF techniques are very interesting additions to list of tools available for understanding laser cleaning. This is a result of the fact that they are used during the ablation process to directly monitor the products being removed during cleaning or to monitor the surface being cleaned, respectively. Conceivably, over the long term such techniques could be harnessed for use in feedback control of the cleaning process.

The LIBS process uses a fiber optic to deliver the light from the plasma, developed during ablation, to an Optical Multichannel Analyzer (OMA). The OMA then looks at the resulting peaks which correspond to various free radicals. While the resulting spectra are poorly understood and very broad-band (also some elements are not easily detected, e.g.. Cl, S, O₂) it is often possible to detect sudden changes in the composition of the ablated material which would indicate material interfaces.

LIF is a non-destructive technique used to analyze the surface of an artwork in situ. Essentially LIF uses a laser beam to excite the surface of the artwork. The fluorescence spectra of the medium is measured. Each different substance will emit a different spectra. Further, work with LIF has the potential to detect atomic species using spectral response and fluorescence lifetime. This technique is limited to analyzing atomic species which have good fluorescence properties or molecular species, which again result in very broad band spectra. Combination of the two techniques can give a reasonably accurate picture of the results of laser ablation.

Accelerated Weathering Exposure and Followup Evaluation

Considerable uncertainty exists as to whether deterioration effects maybe accelerated in the aftermath of laser cleaning or whether they may lead to unanticipated changes in appearance. On the other hand, experience with non-laser xenon flashlamp cleaning of metal surfaces has shown that thermal effects (amorphization of the oxide layer, removal of grain boundaries) may retard the onset of subsequent weathering effects. Controlled testing of cleaned surfaces in the exposure facility of the National Center for Preservation Technology and Training and their subsequent evaluation would be an important phase of this work.

A few other techniques such as time-of-flight mass spectrometry, which has been used very effectively on homogeneous materials by industrial and academic investigators of laser machining and ablation methods, would not be applicable to the projected conservation study because of the high vacuum requirements for their employment. The conditions necessary to use them would not be relevant to the actual cleaning situations encountered in conservation.

PROPOSED CONSERVATION RESEARCH AND TRAINING

As noted here the use of the laser as a tool for art conservation is expanding in a number of directions. It seems clear that to remain abreast of state of the art technologies, the U.S. conservation community has need of a research and training facility similar to those currently available to the European conservation community. It is also clear that such a laboratory would not only serve a national need but would also contribute to the international need for more research in this promising area to take place within a framework of more formal experimental design. It is the conclusion of the authors that this objective could best be served within the context of an operating conservation center with both a steady flow of treatment projects concerning a wide variety of materials and a well equipped conservation science capability. Implicit in this framework is the existence of a highly trained professional staff of both conservators and conservation scientists who actively and collaboratively engage in the treatments and their evaluation.

At a minimum, that laboratory should provide training and guidance in the development, by conservators, of controlled experiments in the use of the YAG laser on stone, terra-cotta, bone, ivory, paper, etc. as do the laboratories in England, Italy and France. In addition, the equipment must be powerful enough to allow further research into modified laser conservation techniques or its capabilities will soon become outdated. In the same sense that it is of little value to buy an old model of computer in today's market, it

would be unwise to buy a laser system with less versatility than is currently available simply because other conservation laboratories already have a certain model which is being promoted to the field. This is especially true in the U.S. laser manufacturing arena with its highly experienced designers and very competitive prices. While their names do not appear as frequently in the conservation context as some of the European manufacturers who have explicitly targeted this market, some of them have provided equipment to European conservators.

To this end a laser conservation laboratory with a versatile YAG system is proposed, to carry on research into laser interactions with a variety of materials. This research should include an array of experiments to determine ablation mechanisms, rates and damage thresholds, for a variety of artifact materials under tightly controlled conditions with long-term followup evaluation. We feel that this type of research would not only benefit the conservation community at large, but would also allow for the demonstration and training of the techniques to American conservators who are interested. Specifically, the research should explore changes in ablation mechanism and damage levels as a function of laser pulse length, intensity/fluence, and wavelength. These experiments should be structured so that the same type of data may be acquired across a range of materials. Conservators should be encouraged to submit special conservation problems, as candidates for inclusion in the study, and to design controlled experiments around these problems. In this way conservation problems which currently are not being adequately addressed by conventional techniques could be investigated. In addition those conservators would have access to data and training on the types of materials they are most often confronted with. The benefits of this process would include the development of a body of reliable data on the short and long term effects of laser cleaning, the development of expertise in this method by both conservators and conservation scientists, and increased skill on the part of conservators in the design of controlled experiments.

The proposed laboratory would benefit tremendously from the addition of an excimer laser system so that a larger emphasis upon wavelength dependence and mechanistic comparisons could be obtained. It is clear that the excimer is a large part of the current expansion in the use of lasers and will certainly be of special interest to paintings and paper conservators.

We propose an additional research component to be integrated into the project which would draw upon a unique laser installation currently coming on-line as a result of changes to the federal government's former superconducting supercollider project. Optical physicists in the U.S. have the opportunity to make use of these facilities which are being converted to

a joint technology transfer venture by government and industry. Virginia's Thomas Jefferson National Accelerator Facility with its continuous electron beam accelerator is currently making its state of the art free electron laser available to outside users at a very nominal fee. The complete tunability of the free electron laser would make possible a small suite of experiments which could settle certain questions about the role of wavelength effects upon cleaning selectivity. This type of interaction will help push U.S. conservation research into the forefront of this rapidly expanding technology just as it has done within the European Community.

The need for a laser conservation research and training facility, which utilizes the talents of trained conservators, conservation scientists and optical physicists, as well as an array of analytical techniques proven in the conservation field, can not be disputed. Until such a research program is initiated here in the United States, conservators will have to travel to Europe for training and information, or simply do without. Considered in this light, the economics of supporting such a laboratory become clearer.

PROPOSED LASER SYSTEMS FOR THE DEVELOPMENT OF CLEANING PROTOCOLS IN CONSERVATION

Two clearly separate systems for laser cleaning are currently undergoing development in the world of conservation. The first, more established, system is that of mid-power YAG to ablate dirt and pollutant crusts from objects. The second system, more recently utilized, is to incorporate the excimer into this cleaning problem and more novel processes. There are strong advantages and strong disadvantages to both.

Specifically, the YAG has the advantage of being somewhat selective in its cleaning properties. Unfortunately, the mechanisms for cleaning using a YAG tend to be thermal and photo-mechanical and have the ability to do significant damage to the work of art in a single shot, if incorrectly used. Conversely, the excimer ablates using a process which is probably primarily photochemical in nature. Therefore, each shot removes a discrete amount of material, with the properties of the material being much less of a factor. The excimer is not inherently selective, but each individual pulse of the laser is less likely to do significant damage. Rather, it is the repeated application of the UV light, which will continually remove material, that constitutes a danger. Both systems can be expected to have advantages with regards to some specific types of material to be ablated. For example, the YAG is much more efficient at removing thick layers of black grime, while the excimer is often better at removing biological materials and tough, pliable

films. In either case it is imperative that trained conservators and conservation scientists direct the employment of this type of equipment.

To this end we propose the following three laser systems (two YAG and one excimer) which could be used in one of two possible schemes for research and training in lasers for conservation. The first scheme would be to acquire a stand-alone infrared YAG laser which would also allow for a very limited research program in the UV and visible ranges. The second, and optimal, scheme would be to acquire a slightly simpler and less powerful YAG which we propose for use in conjunction with an excimer, to support a complete state-of-the-art program in laser cleaning investigations. In each case there are a number of system, diagnostic and safety tools which are required to maintain the lasers, to protect the operators and to interpret the results of the cleaning process. These are also discussed in the following paragraphs. Extensive analytical support would also be required in the form of staff expertise and instrumentation within the context of an operating conservation science facility. The principal analytical techniques expected to benefit such a program are described in the section on analytical techniques.

The first proposed scheme is to acquire a relatively higher power YAG (above 600 mJ at 1064nm, In). The system operates at 30 Hz and can be doubled into the second harmonic (532nm, green), third harmonic (355 nm, near ultraviolet) and fourth harmonic (266nm, ultraviolet). With corresponding losses in efficiency for each shift in harmonic, the power expect in the UV wavelength is 50mJ. The system is large and powerful enough to accomplish cleaning of larger areas in a reasonable amount of time. The system is not easily portable as it requires a separate chiller for cooling water. This type of YAG would provide enough power for any anticipated application and could be run in the free-running (non-Q-Switch) mode. While the UV wavelength power is not optimal, and the thermal drift which is endemic in frequency doubled lasers would have to be accounted for, this laser could also be used to began a limited program in research at various shorter wavelengths.

The second, optional scheme would involve a more limited YAG laser with lower power in a more compact system designed to be used in the IR and visible wavelengths. This system would have an output power of about 500mJ and a repetition rate of 30Hz. It is quite comparable with the systems sold by the European manufactures named above. In addition, unlike their systems, it will operate in the free-running (long pulse mode) and in the green, near UV and UV. This system is designed to be an all-purpose system for lab and field work with an unusually broad array of options.

Both of the above systems would include an articulated arm for ease of use (usable in the IR wavelength only and replaced by the doubling or wavelength separation packages when other colors are desired).

In addition, the YAG systems would require the following additional lab items for support of the project: laser safety glasses (four pair), a power meter, focusing lenses (two), a HeNe laser for pointing and for profiling of the plasma ejecta from the surface of the object, a video camera for monitoring the ablation process and a work station with worm drive translation devices for manipulating the art or mock-ups in a well-controlled manner, a CCD camera, a computer with CD ROM, a "single board" spectrometer for performing LIBS and LIF, and frame grabber and, finally, an IR viewer to allow one to view the laser beam. The lab would have to build some mounts and tracks for handling the art and a ducted exhaust for removal of particulates resulting from the ablation process.

The excimer system which would be an integral part of the second scheme would deliver more than 600mJ at the 248nm wavelength. While the system is not portable, it is primarily for anticipated for research on items such as paintings, which are. The laser should be able to operate with a number of different fluorinated gasses which will generate a number of wavelengths of UV light.

In addition to the excimer itself and the support equipment described above which is common to both systems, the laboratory would require the addition of a small gas scrubber to capture halogens in the laser cavity exhaust.

ACKNOWLEDGEMENTS

The authors are indebted to the staff members of the following groups for lengthy discussions regarding their research:

- Foundation for Research and Technology Hellas (FORTH), Crete
- Opificio della Pietre Dure e Laboratori di Restauro, Firenze,
- Laboratoire de Recherche des Monuments Historiques, Champ-Sur-Marne (LRMH),
- National Museums and Galleries on Merseyside / University of Liverpool team

In addition, the following individuals gave freely of their time for discussions:

- Dr. Henry Helvajian of The Aerospace Corporation's Nanotechnology Working Group, El Segundo,

- Dr. Wolfgang Kautek, Berlin,
- Architect Giancarlo Calzagno, Padua,
- Dr. Dusan Stulik and Dr. Alberto Tagle of the Getty Conservation Institute, Los Angeles,
- Dr. John Asmus, University of California at San Diego

The authors take full responsibility for any errors or omissions in the representation of those discussions here. We thank Ms. Agnes Ballestrem for providing a copy of the laser cleaning review conducted under the auspices of the Amsterdam's Centraal Laboratorium voor Onderzoek van Voorwerpen van Kunst en Wetenschap by Ms. Giovanna Di Pietro. We thank Dr. Mark Gilberg, Scientific Coordinator of the NCPTT for his initiation and support of this investigation and Dr. Pieter Meyers, Head of Conservation of the Los Angeles County Museum of Art for his review of the text and helpful suggestions.

BIBLIOGRAPHY

The articles below are intended to be representative of the publications in conservation and include a very small number of publications from other fields which the authors found to be relevant to the preparation of this report.

Adair, N., L. Carlyle, *The Application of Laser Chemistry in Conservation Treatments Report on Initial Investigations*, Eighth IIC-CG Annual Conference, Abstracts, Quebec, June 20-24, 1982, pp. 19-20

Afanasef, Y. V., O. N. Kroklin, Vaporisation of Matter Exposed to Laser Emission, Soviet Physics. Journal of Experimental Theoretical Physics, vol. 25, 1967, pp. 639

Amoroso, G.G., V. Fassina, Stone Decay and Conservation, Materials Science Monographs, 11, Elsevier, Amsterdam, 1983, pp. 287-290

Andrew, J.E., P.E. Dyer, D. Forster and P.H. Key, Direct Etching of Polymeric Materials Using a XeCl Laser, Applied Physics Letters, vol. 43, 1983, pp. 717-719

Anglos, D., et al. Laser-Induced Fluorescence in Artwork Diagnostics: An Application in Pigment Analysis. Applied Spectroscopy. Vol. 50 number 10, 1996.

Anon., Für die Reinigung von Oberflächen vie/er Materialien: 1st Laser die Methode der Zukunft?, Restauro, vol. 102, 1996, #2, pp. 96-99

Ashurst, J., N. Ashurst, Practical Building Conservation. Vol 1: Stone Masonry, English Heritage Technical Press, England, 1988. p. 57

Ashurst, John, Cleaning Masonry Buildings, Butterworths Series in Conservation and Museology, London, 1990, pp. 125-154

Asmus, J. F., Light Cleaning: Laser Technology for Surface Preparation in Arts, Technology and Conservation, Vol 3, #3, 1978, pp. 14-18

Asmus, J., C. Murphy, W. Munk, Studies on the Interaction of Laser Radiation with Art Artifacts, Proceedings of the Society of Photo-optical Instrumentation Engineers, vol. 41, 1973, pp. 19-27

Asmus, J.F., Laser Consolidation Tests, May, 22. 1974. unpublished mss.

Asmus, J.F., *Use of Lasers in the Conservation of Stained Glass, Conservation in Archaeology and the Applied Arts. Preprints of the Contributions to the Stockholm Congress, June 2-6, 1975, pp. 139-142*

Asmus, J. F., *The Development of a Laser Statue Cleaner, Proc. of the 2nd International Symposium on the Deterioration of Building Stones. N. Beloyannis, ed., National Technical University, Athens, Sept. 1976, pp. 137-141*

Asmus, J. F. , *Surface Preparation with Pulsed Laser and Flash-lamp Systems, unpublished mss.*

Asmus, J. F., et al., *Surface Morphology of Laser-Cleaned Stone, Lithoclastia, vol 1976, #1, pp. 23-46*

Asmus, J. F., *Properties of Laser-cleaned Carrara Marble Surfaces, Geological Society of America Bulletin vol 1977, #2, pp. 81-88. also presented at the 1974 Annual Meeting of the Geological Society of America: Preservation of Stone*

Asmus, J.F., et al. *Performance of the Venice Statue Cleaner, Preprints of the Papers Presented at the Fifth Annual Meeting of the American Institute for Conservation of Historic and Artistic works, Boston, May 30-June 2, 1977, pp.5-11*

Asmus, J.F., *Lasers in Conservation, Conservation News. vol. 34, 1987, pp. 9-10*

Asmus, J. F., *Light for Art Conservation, International Science Review, vol. 12, 1987, pp. 171-*

Asmus, J. F., *More Light for Art Conservation, IEEE Circuits and Devices Magazine, Vol 2, #2, March, 1996, pp. 6-14*

Bachmann, F., *Large Scale Application for Excimer-laser: Via-hole-drilling by Photo-ablation, SPIE, vol. 1377, 1990, pp. 18-29*

Bertholon, Regis. *Laser la resurrexion de La pierre actualités des recherches au LRMIT, Conservation, restauration des biens culturels revue de l'ARAFU. #31, 1991, pp. 20-42*

Boutsikaris, L., et al. *Computer Generated Holographic Diffractive Structures by Direct Excimer Laser Microetching, Proceedings of Photonics West*

Conference on Optoelectronic, Microphotonics, and Laser Technologies, San Jose, California, 1995,

Brannon, J.H., *Micropatterning of Surfaces by Excimer Laser Projection*, Journal of Vacuum Science and Technology. vol. B7, 1989. pp. 1064-1071.

Building Research Establishment. Cleaning External Surfaces of Buildings. Her Majesty's Stationery Office, London, 1983.

Campanella, C., *La Conservazione della "pelle" lapidea: dalle tecniche tradizional all 'impiego del laser*. Recuperare, #50, 1990, pp. 610-613, 635-638.

Cooper, M.I., et al. *A Comparative Study of the Laser Cleaning of Limestone*. Proceedings of the 7th International Congress on Deterioration and Conservation of Stone, Lisbon, June 1992. pp. 1307-1315

Cooper, M.I., et al. *The Evaluation of Laser Cleaning of Stone Sculpture*. Structural Repair and Maintenance of historical buildings III. Computational Mechanics Publications, 1993. p. 259-266

Cooper, M.I., et al., *Laser Cleaning of Limestone Sculpture*. Conservation Sciences in the U.K. Preprints, Glasgow, May 1993. James and James, London. pp. 29-32

Cooper, M.I., et al. *The Use of Laser Energy to Clean Polluted Stone Sculpture*. Journal of Photographic Science, #40, 1992, pp. 55-59.

Cooper, M., et al. *Light years ahead?* Natural Stone Specialist. vol 29, # 11, 1994. pp.24,25,27,30,31,35.

Delgado, J., E. Rodrigues, E. De Castro. *Some remarks on the efficacy and harmfulness of stone cleaning*. The Conservation of Monuments in the Mediterranean Basin: the Influence of Coastal Environment and Salt Spray on Limestone and Marble. Proceedings of the 1st International Symposium. Bari, June 7-10, 1989. Fulvio Zezza, ed., Grafo Edizioni, 1990, pp. 491-494.

Desson, K., M. Weaver, *The Business of Cleaning*. Canadian Heritage. vol. 1983, # 39, pp 25-28..

Dupont, A., P. Caminat, P. Bournot. *Efficiency of Metallic Materials Ablation Using Impulsional Laser with Several Wavelengths*. SPIE, Proceedings of the

Ninth International Symposium on Gas Flow and Chemical Lasers. 21-25 September, 1992, Crete. C. Fotakis, ed., vol. 1810, 1992. pp. 696-699

D'Urbano, M., et al. *La pulitura laser di superfici lapidee: messa a punto di una metodologia standardizzata per il controllo degli effetti. La conservazione dei monumenti nel bacino del Mediterraneo: atti del 3 simposio internazionale*. Venice, 1994. pp. 955-962.

* * *, *Effects of Ultraviolet Laser Radiation on the Wetting Out and Adhesive Properties of Synthetic Fibers*. Melliand Textilberichte: International Textile Reports. vol. 72, #11. Nov. 1991, p. 388

Ermentini, Marco. *Il Palazzo comunale di Crema: la conservazione delle facciate*. Arkos. vol. 20, 1992. pp.16-32

Fazio, Giuseppina. *I metodi di pulitura prevalentemente usati*. Manutenzione e restauro: conservazione e consolidamento dei materiali lapidei. volumi cresme, #10, 1985. pp. 99-129.

Fotakis, Costas. *Lasers for Art's Sake!*. Optics and Photonics News. vol. 6, #5, May 1995. pp. 30-35.

Fotakis, C. (ed.), LACONA workshop on Lasers in the Conservation of Artworks. Ed. C. Fotakis, October 4-6, 1995, Heraklion, Crete

Fotakis, C., et al., *Laser Technology in Art Conservation*. Proceedings of Resonance Ionization Spectroscopy, Pennsylvania State University, July 1996

Fujiwara, H. et al. *Each dopant can absorb more than ten photons: Transient absorbance measurement at excitation laser wavelength in polymer ablation*. Applied Physics Letters, vol. 64, # 18, May 1994. pp. 2451-2453.

Helvajian, H., ed., Microengineering Technology for Space Systems, The Aerospace Corporation, El Segundo, September 30, 1995

Hontzopoulos, E., et al. *Excimer Laser in Art Restoration*. SPIE, The International Society of Optical Engineering; Proceedings of the Ninth International Symposium on Gas Flow and Chemical Lasers. Crete, 21-25 September, 1992, C. Fotakis, ed., vol. 1810, 1992. pp. 748-751

Hontzopoulos, E., et al. *Art Conservation Studies by Eximer Laser*. Conference on Lasers and Electro-Optics Europe. 1994, IEEE #21523. pp. 7-8

Hontzopoulos, E., et al. *Laser Cleaning and Diagnostics in Art Conservation*. Conference on Lasers and Electro-optics, Vol 15, May 1995. p. 349.

Hughes, S. *Old Masters come Clean with Lasers*. New Scientist. vol. 134, #1827, 1992, p. 21.

Jing, D., Luo, Y., Gao, M. *Research with pulsed laser to remove the rust on bronze*. Proceedings of the EEC China workshop on preservation of cultural heritages. Xian, Shaanxi, Sept. 25-30, 1991. pp. 102-109

Joecklé, R. *Can near-IR and visible lasers be used as processing lasers?* SPIE, The International Society of Optical Engineering; Proceedings of the Ninth International Symposium on Gas Flow and Chemical Lasers. Crete. ed. C. Fotakis. vol. 1810, 1992. pp. 582-585.

Jungbluth, E. *Laser Cleaning Renews Art Objects*. Laser Focus World, Sept 1992. p.38

Kazragis, Evaldas. *Lazerines technikos ir holografijos taikymo galimybes paminklu restauravime*. Istorijos ir Kultūros Paminklų Tyrimai ir Restauravimas Lietuvos TSR 1976-1980 m. Vilnius, 1980, pp. 210-211.

Koren, G., J.T.C. Yeh. *Emission Spectra, Surface Quality and Mechanism of Excimer Laser Etching of Polyimide Films*. Applied Physics Letters, vol. 44, 1984. pp. 1112-1114.

Kokai, F., et al. *X-ray Photoelectron Spectroscopy Studies on Modified Polyimide Surfaces After Ablation with a KrF Excimer Laser*. Journal of Applied Physics, vol. 66, 1989. pp. 3252-3255.

Kuper, S., J. Brannon. *Ambient Gas Effects on Debris Formed During KrF Laser Ablation of Polyimide*, Applied Physics Letters, vol. 60, 1992. pp. 1633-1635.

Larson, John. *The Conservation of Stone Sculpture in Museums* Conservation of Building and Decorative Stone. J. Ashurst, ed., Butterworths Series in Conservation and Museology, London, 1990. pp. 197-207.

Larson, John. *Current developments in the application of laser technology to the treatment and recording of artworks*. Conservation News. # 53, 1994. pp. 13-14

Larson, John. *Laser Technology Applied to the Conservation of Sculpture*. LACONA. October, 1995

Laurenzi Tabasso, M. *Techniche di pulitura deimateriali II Hestauo delle Costruzioni in Muratura. Problemi metodologici e tecniche di consolidamento*. Atti del 3 corso di informazione assircco. Palermo, October 22-25, 1980. pp. 69-72.

Laurenzi Tabasso, Marisa. *La pulitura dei materiali lapidei Metodologia e prassi della conservazione musiva: volume secondo: atti del II Seminario di studi "Metodologia e prassi della conservazione musiva" promosso dall'Istituto Statale d'Arte per il Mosaico "Gino Severini"*. Ravenna, 1986. pp. 89-94.

Lavoi, P. *Laser Paint Stripping Offers Control and flexibility*. Laser Focus World, Nov 1994. pp.75-80.

Lazar, S., et al. *Controlled Modification of Organic Polymer Surfaces by cw Far-ultraviolet (185 nm) and Pulsed-laser (193 nm) radiation: XPS Studies*. Journal of the American Chemical Society, vol. 106, 1984. pp. 4288-4290.

Lazzarini, L., J. F. Asmus, L. Marchesini,. *Laser for the Cleaning of Statuary: initial results and potentialities*. le Colloque International sur la Détérioration des Pierres in Oeuvre. Centre de la Recherche et d'Etudes Océanographiques, La Rochelle, 1972. pp.89-94.

Lazzarini, L., J. Asmus. *The application of laser radiation to the cleaning of statuary*.Bulletin of the American Institute for Conservation of Historic and Artistic Works. vol. 13, # 2, 1973. pp. 39-49.

Lazzarini, L. La pulitura dei materiali lapidei da costruzione a scultura: metodi industriali e di restauro. Casa Editrice Dott. Antoniao Milani, Padua, 1981

Lazzarini, L., M. Laurenzi Tabasso. Il restauro della pietra. Casa Editrice Dott. Antoniao Milani, Padua, 1986.

Lazzarini, L., et al. La restauration de la pierre. Maurecourt, France, 1989. pp. 121-124

Liu, K., E. Garmire. *Paint Removal Using Lasers*, Applied Optics, vol. 34, #21, July 20, 1995. pp. 4409-4415

Li Quan, Shen Yingping. Wenwu baohu yu kaogu kexue. vol 2, #1, 1990. pp. 22-25.

Loton, A., R. Goodwin. *The cleaning of materials by laser*. Conservation News. #52, 1993. pp. 11-12

MacCormack, M., *Cleaning Up with Lasers*, Industrial Laser Review, June 1996, pp. 7-8

Maravelaki, P., et al. *Investigation on surface alteration of limestone related to cleaning processes*. Proceedings of the 7th International congress on Deterioration and Conservation of Stone. Lisbon, June 15-18, 1992. pp. 1093-1102

Maravelaki, P., *Cleaning with Laser Radiation on Istria Stone*. in: Materials Issues in Art and Archaeology III. P. Vandiver, et al., eds., Materials Research Society Symposium Proceedings Volume 267, MRS. Pittsburgh, 1992. pp. 955-961.

Maravelaki, P., et al. *Laser Induced Breakdown Spectroscopy as a diagnostic technique for the Laser Cleaning of Marble*. Spectrochimica Acta. In Press

Martini, A. *Utilità del Laser nel Restauro della Pietra e del Marmo*, Soprintendenza ai Bien Artistici e Storici di Venezia, Venezia 1978. Quaderno. #7. pp. 151-154

Matthias, E., et al. *In-situ Investigation of Laser Ablation of Thin Films*. Thin Solid Films. vol. 254, 1995. pp. 139.

Michaux, N. *A Rainbow-Coloured Miracle*. Unesco Sources. vol. 44, 1993. pp. 15-16

Mihailov, S., W. Duley, *Study of the Ablation Threshold of Polyimide (Kapton H) Utilizing Double Pulsed XeCl Excimer Laser Radiation*, Journal of Applied Physics. vol. 69, #7, 1991. pp. 4092-4102

Niino, H., A. Yabe, *Positively Charged Surface Potential of Polymer Films After Excimer Laser Ablation: Application to Selective-area Electroless Plating on the Ablated Films*. Applied Physics Letters, vol. 60 1992. pp. 2697-2699.

Orial, G., J.P. Gauffillet, *Nettoyage des monumentes historiques par desincrustation photonique des salissures*, Proceedings: Technologie

industrielle, conservation, restauration du patrimoine culturel, colloque/AFTPV-SFIIC, Nice, 1989. pp. 115-125

Orial, G. Technique de nettoyage de la statuaire monumentale par desincrustation photonique. Realisation d'un prototype mobile. Conservation of Stone and Other Materials: Proceedings of the International RILEM/UNESCO Congress, 1993. M-J. Thiel, ed., pp. 542-549

Orial, G., V. Vergès-Belmin, Monuments at technologie de pointe, la tour de France laser. Monumental, Revue scientifique et technique de la sous-direction des monuments historiques, Direction du Patrimoine, Ministère de la Culture, Number 10 & 11, December, 1995. pp. 23-35

Orial, G., Nettoyage des Pierres des Monuments Français par Laser, in: Proceedings of the International LCP Congress on Conservation and Restoration of the Cultural Heritage, Montreux. September 25-29, 1995, in press

Panati, C., G. Dewey. Have Laser, Will Travel, Science. March 28, 1977. p.87.

Peruzzi, R. Il trattamento dei materiali: modailta di appilcazione in laboratorio, prove di qualificazione, modalita di applicazione in opera. Primo corso di aggiornamento sui problemi delta salvaguardia del patrimonio artistico monumentale, Milano, May-June, 1981, vol. 4., Regione Lombardia, Assessorato alla Cultura, Milan, 1981, pp. 1-42.

Petit, G.H., R. Sauerbrey, Fluence-dependent Transmission of Polyimide at 248 nm Under Laser Ablation Conditions. Applied Physics Letters, vol. 58, 1991. pp. 793-795.

Polonovski, M., B. Oger. L 'utilisation de la sole dans las plans-reliefs: faisabilité du nettoyage au laser. La conservation des textiles anciens: journées d'études de la SFIIC. Angers, Oct. 20-22, 1994. SFIIC, Champs-sur-Marne, pp. 83-94.

Radhakrishnan, Gaori. Excimer Laser Ablation of Contaminated Poyimide, SPIE, Laser-assisted Fabrication of Thin Films and Microstructures. Québec, August 1993, SPIE vol. 2045. pp. 40-46

Radziemski, L.J. and D.A. Cremers. Spectrochemica/Analysis Using Plasma Excitation, Laser-induced Plasma and Applications. Marcel Dekker, inc. New York, 1989. pp. 295-325.

Reisenberg, L. *John Asmus: the Laser's Artful Aimer*. Sciqwest. vol 55, # 3, March 1982. pp. 22-24

Rossi-Doria, P., M. Laurenzi Tabasso. *Materiali lapidei: diagnosis, interventi, controlli*, La conservation dei monumenti. Metodologie di ricerca e tecniche di consolidamento contro il degrado. Atti del 1 corso di informazione assirico. Perugia, November 6-8, 1997. pp. 25-39.

Ruitang, Wen. *Treasures from Ancient Chinese Tomb*. The Courier, issue #1, 1987. pp. 32-33

Shekede, Lisa. *Lasers: a preliminary study of their potential for the cleaning and uncovering of wall paintings*. 1994, unpublished master's thesis, Courtauld Institute of Art, London

Siano, S., et al., *Cleaning Processes of Encrusted Marbles by Nd: YA G Lasers Operating in Free Running and Q-switching regimes*. Applied Optics. In press.

Siano, S., et al., *Refractive Fringe and Stark Diagnostics of Laser Induced Plasmas on Solid Targets*, unpublished mss.

Skordoulis, C.D., C.E. Kosmidis. *Laser Ablation at 337nm of Nitrocellulose and Nylon Sensitized with Organic Dopants*. SPIE, The International Society of Optical Engineering; Proceedings of the Ninth International Symposium on Gas Flow and Chemical Lasers. Crete. ed. C. Fotakis. vol. 1810, 1992. pp. 646-649

Skoulikidis, Th., et al. *Melete apokatastaseos tou Parthenonos: tomos 3c = Study for the restoration of the Parthenon: vol 3c*. Committee for the Preservation of the Acropolis Monuments, Athens, 1994

Snethlage, R., Claus Arendt. *Baudetafi Steinreinigung*. Arbeitsblaetter des bayer. Landesamtes fuer denkmalpflege. vol. 1981, #23. pp. 1-21

Snethlage, R., C. Arendt. *Reinigung von Naturwerkstein aus der Sicht der Denkmalpflege*. Bautenschutz + Bausanierung. issue # 2, 1983. pp. 42-50.

Soccodato, C. *Risanamento statico delle pendici rocciose del versante ovest sud-ovest del centro storico di narni*. Atti del XIV convergno nazionale congress of geotechnic. Florence, October 28-31, 1980. pp. 267-274.

Srinivasan, R., W.J. Leigh. *Ablative Photodecomposition: Action of far ultraviolet (193 nm) Laser Radiation on Poly(ethylene terephthalate) Films*, Journal of the American Chemical Society. vol. 104, 1982. pp. 6784-6785

Srinivasan, R., et al., *Ultraviolet Laser Ablation of Polyimide Films*, Journal of Applied Physics. vol. 61, 1987. pp. 372-376.

Srinivasan, R., B. Braren, *Ablative Photodecomposition of Polymer films by Pulsed Far-ultra violet (913 nm) Laser Radiation: Dependence of Etch Depth on Experimental Conditions*, Journal of Polymer Sciences, vol. 22, 1984. pp. 2601-2609

Srinivasan, R., B. Bodil. *Influence of Pulse Width on Ultraviolet Laser Ablation of Poly(methyl methacrylate)*. Applied Physics Letters, vol. 53, # 14., Oct 1988. pp. 1233-1235.

Srinivasan, R., et al., *The Significance of a Fluence Threshold for Ultraviolet Laser Ablation and Etching of Polymers*. Journal of Applied Physics, vol. 67, 1990. pp. 1604-1606

Stone, Tom. *Laser Cleaning Demonstration*. CCI Newsletter, issue # 17, Canadian Conservation Institute, Ottawa, March, 1996. pp. 13-14.

Sutcliffe, E. and R. Srinivasan. *Dynamics of UV Laser Ablation of Organic Polymer Surfaces*. Journal of Applied Physics, vol. 60, 1986. pp. 3315-3322

Szczepanowska. *A Study of the Removal and Prevention of Fungal Stains on Paper*. Journal of the American Institute for Conservation, vol. 31, #2, 1992, pp. 147-160

Tam, A.C., et al. *Laser Cleaning Techniques for the Removal of Surface Particulates*. Journal of Applied Physics, vol. 71, 1992. pp. 3515-

Torraca, Giorgio. *Treatment of stone in monuments a review of principles and process*. The Conservation of Stone 1, Proceedings of the international symposium. Bologna, June 19-21, 1975, Centro per la Conservazione delle Sculture all'Aperto, Bologna, 1976. pp. 297-315

Vergès-Belmin, V., C. Pichot and G. Oriol. *Elimination des croûtes noires sur marbre et craie; a quel niveau arrêter le nettoyage?* Conservation of Stone and Other Materials, Proceedings of the International RILEM/UNESCO Congress, 1993, Paris, Vol. 2, E. & F. Spon Ltd., London, 1993, p. 534-541.

Vergès-Belmin, V., Pichot, C., Oriol, G. *Use of petrography for the comparison of laser-beam and microsandblastion cleaning techniques.* in: Eurocare-Euromarbie EU 496: proceedings of the fourth workshop. Aries, Nov. 3-6, 1993. R. Snethiage, V. Vergès-Belmin, eds., Bayerisches Landesamt für Denkmalpflege, Munich, 1994

Vergès-Belmin, V., Cathédrale Notre-Dame, facade occidentale, portail norde, essais comparatifs de nettoyage, rapport LRMH #403 E, May 18, 1995

Vergès-Belmin, V., *Comparison of Three Cleaning Methods.* LACONA, October 1995

Virolleaud, F. *Ravalement, mode d'emploi* Les cahiers techniques du bâtiment. issue # 125, April 1991. pp. 101-111.

Vitkus, J. R., John Asmus. *Treatment of leather and vellum with transient heating.* Preprints of Papers Presented at the Fourth Annual Meeting of the American Institute for Conservation of Historic and Artistic Works. Dearborn 1976., AIC, Washington, 1976, pp. 111-117.

Wainwright, I., T. Stone. *Experiments to remove wax crayon from petroglyphs in marble.* American Indian Rock Art: Proceedings of the International Rock Art Conference and Annual Meeting of the American Rock Art Research Association. vol. 16, ARARA, 1990. pp. 21-33.

Wilson, Claire. *Still Crazying After all these Years.* France Magazine. #28, 1993. pp. 14-17.

Weeks, Christopher. *Laser Cleaning at Amiens Cathedral,* Conservation News. Issue 58, November 1995

Wolff-Rottke, G., H. Schmidt, A Scholl, J. Ihiemann. *Micro Machining with Excimer Lasers: Photoablation and Plasma Sputtering.* SPIE, Proceedings of the Ninth International Symposium on Gas Flow and Chemical Lasers. 21-25 September, 1992, Crete. C. Fotakis, ed., vol. 1810, 1992. pp.650-653

FIGURE LEGEND

- 1) Schematic Diagram of a Typical Excimer Laser's Gas Delivery System
- 2) Schematic Diagram of a Typical Solid State Laser
- 3) Schematic Diagram of a Typical YAG Laser Equipped for Frequency Doubling, Twice Doubling, and Wavelength Selection. A Profile of the Beam Energy Density is Shown Inset.
- 4) Portal Sculptures of the Cathedral of Cremona During Cleaning, 1989
- 5) Partially Completed Laser Divestment of a Typical Black, Urban Sulfation Crust Obscuring a Marble Surface, Artist: Willigelmo (12th century), Cremona
- 6) Severely Eroded Stone with Remnants of Black Sulfation Crust, Cathedral of Amiens
- 7) Marble Bust During Laser Cleaning at the University of Padua, by Arch. Giancarlo Calcagno
- 8) Typical Spatial Distribution of Beam Energy from a YAG Laser with Standard Quality YAG Rod. Top: Three Dimensional Projection of Beam Density, Bottom: Vertical and Horizontal Line Profiles Thorough the Beam.
- 9) Three Dimensional Projection of Beam Density for a Typical Excimer Laser Displaying Square Profile and Greatly Enhanced Uniformity as Compared to the YAG Depicted in Figure 9.

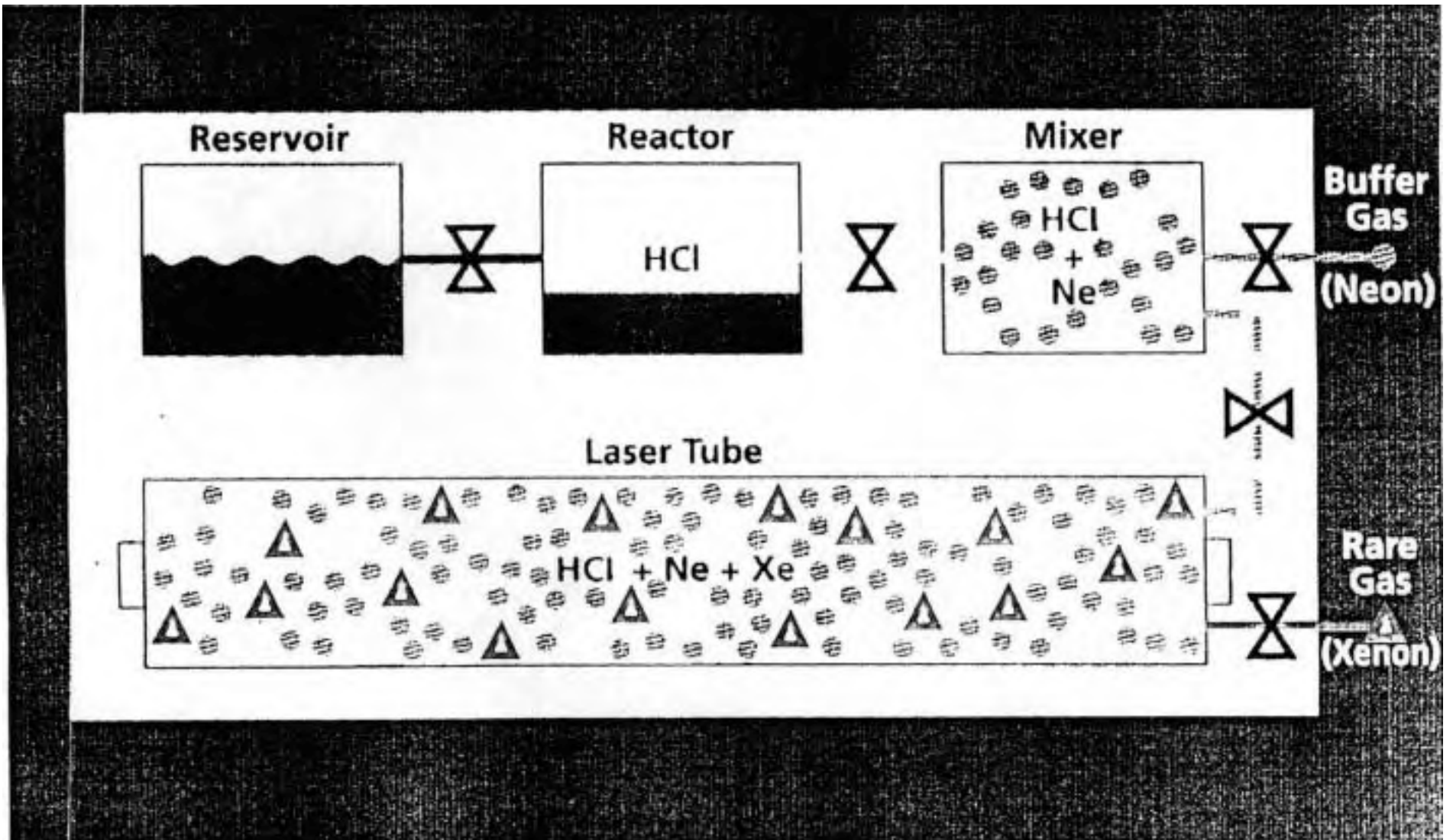

Figure 1

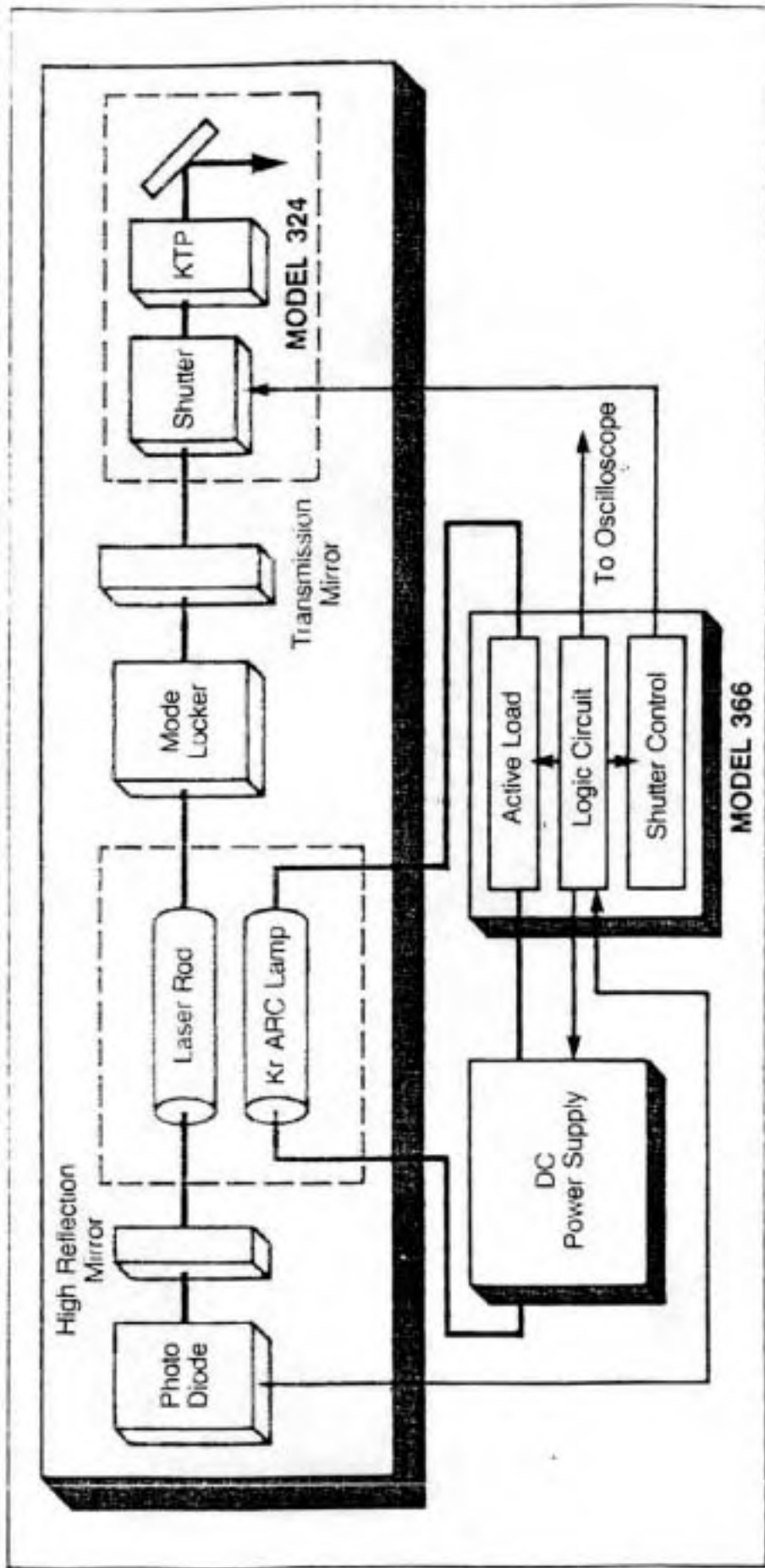
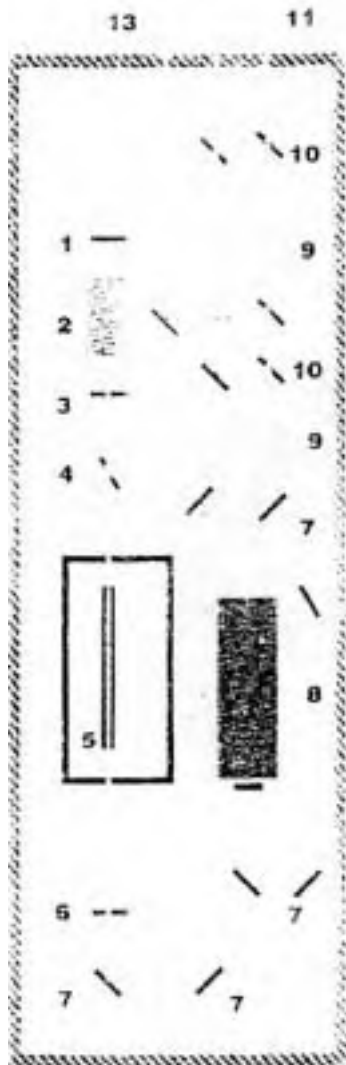
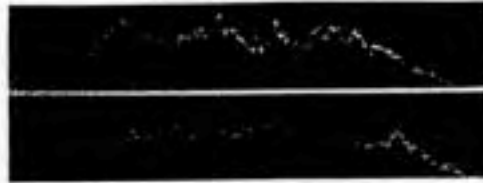

Figure 2



Powerlite 6000 beam profile



near field, 1064 nm at 10 Hz

1. Beam splitter
2. Parabolic mirror
3. $\lambda/4$ plate
4. Dichroic polarizer
5. Output coupler
6. Gaussian input coupler
7. Focusing mirror
8. Output injection coupler
9. Half-wave generator
10. Far-field separator
11. Beam splitter
12. 12/13/20 lens
13. 104 mm lens

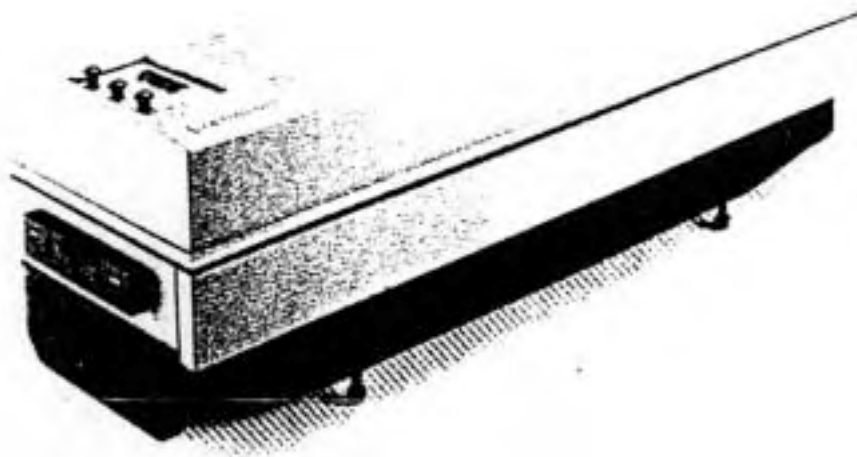

Figure 3



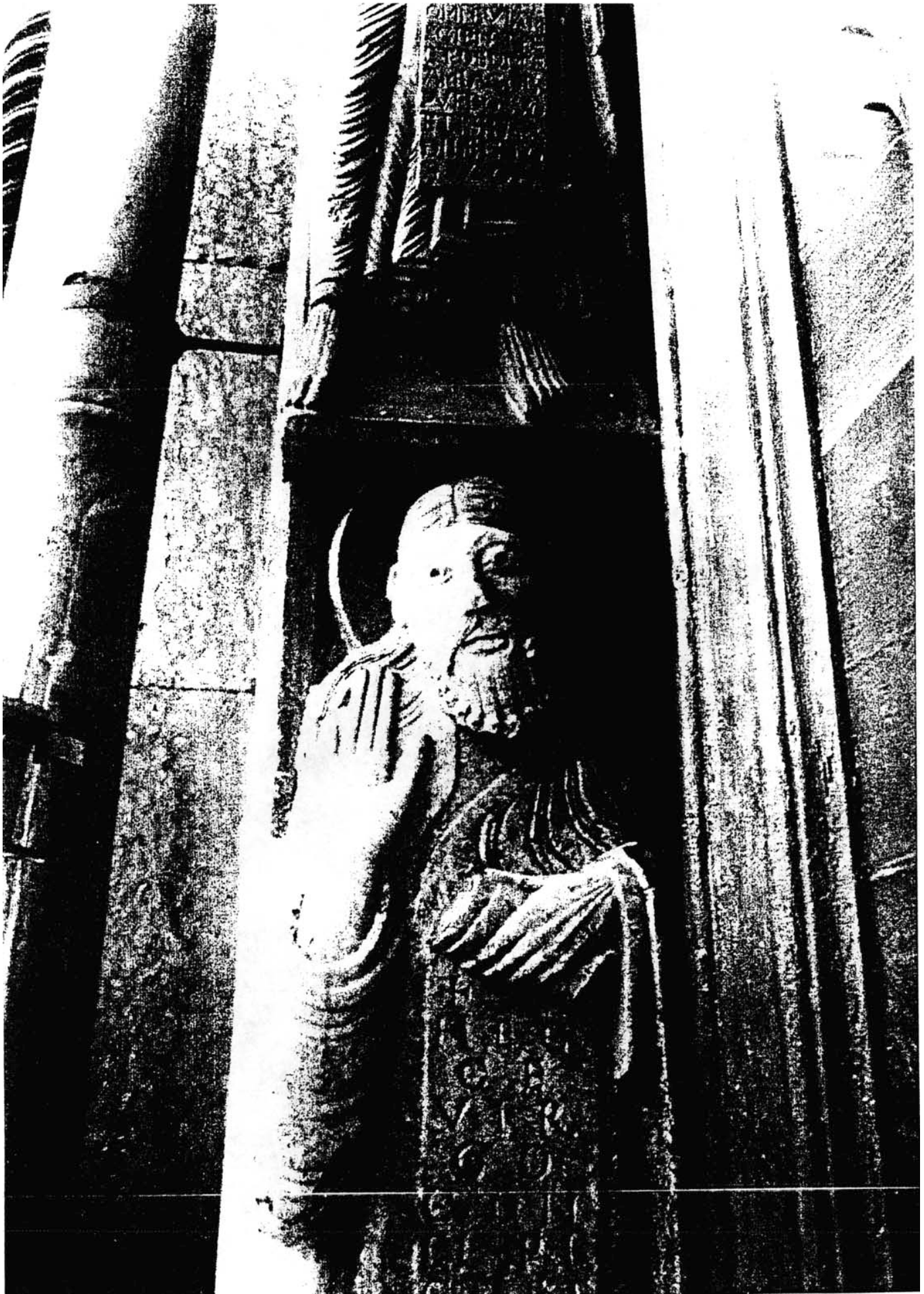
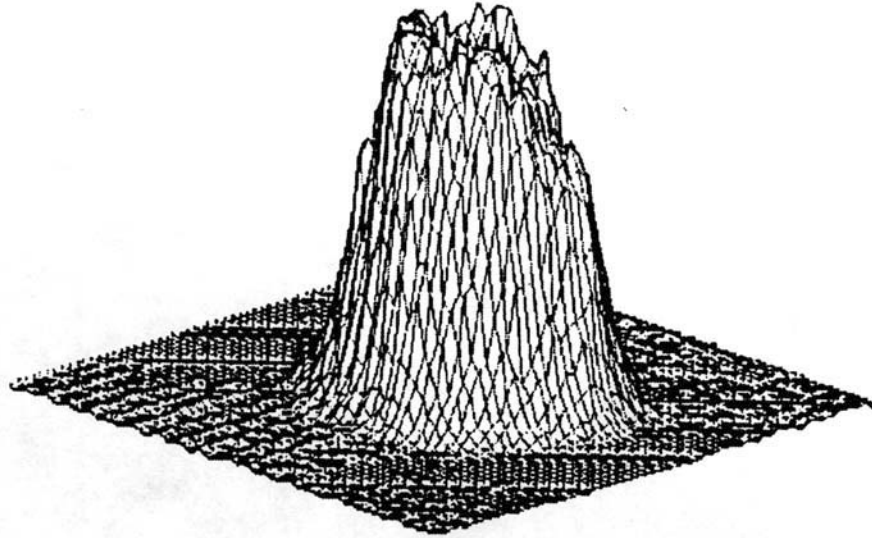





Figure 7

Spatial Mode -



Typical 70% coefficient beam profiles. Vertical [top], horizontal (bottom) measured in the near field at 1m.

$$f(r) = e^{-\left(\frac{r}{w_0}\right)^2}, n=2, w_0 = \text{beam waist}$$

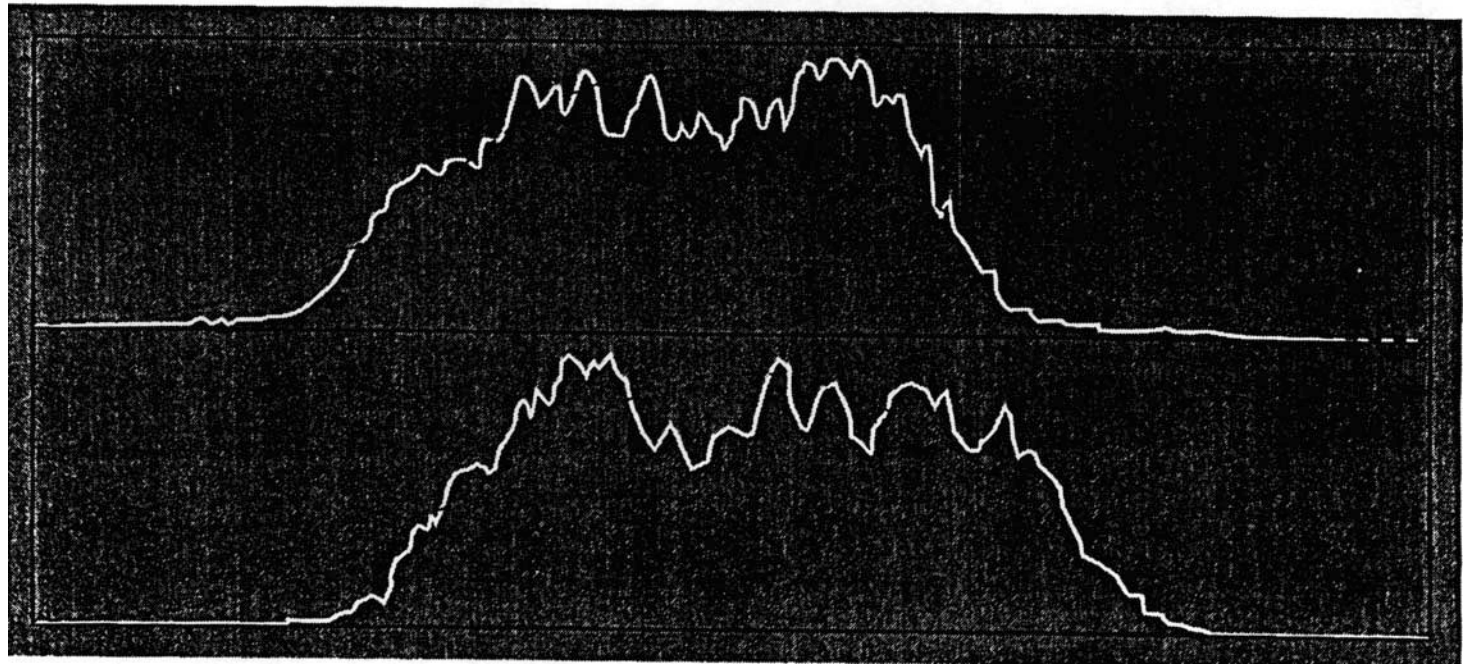
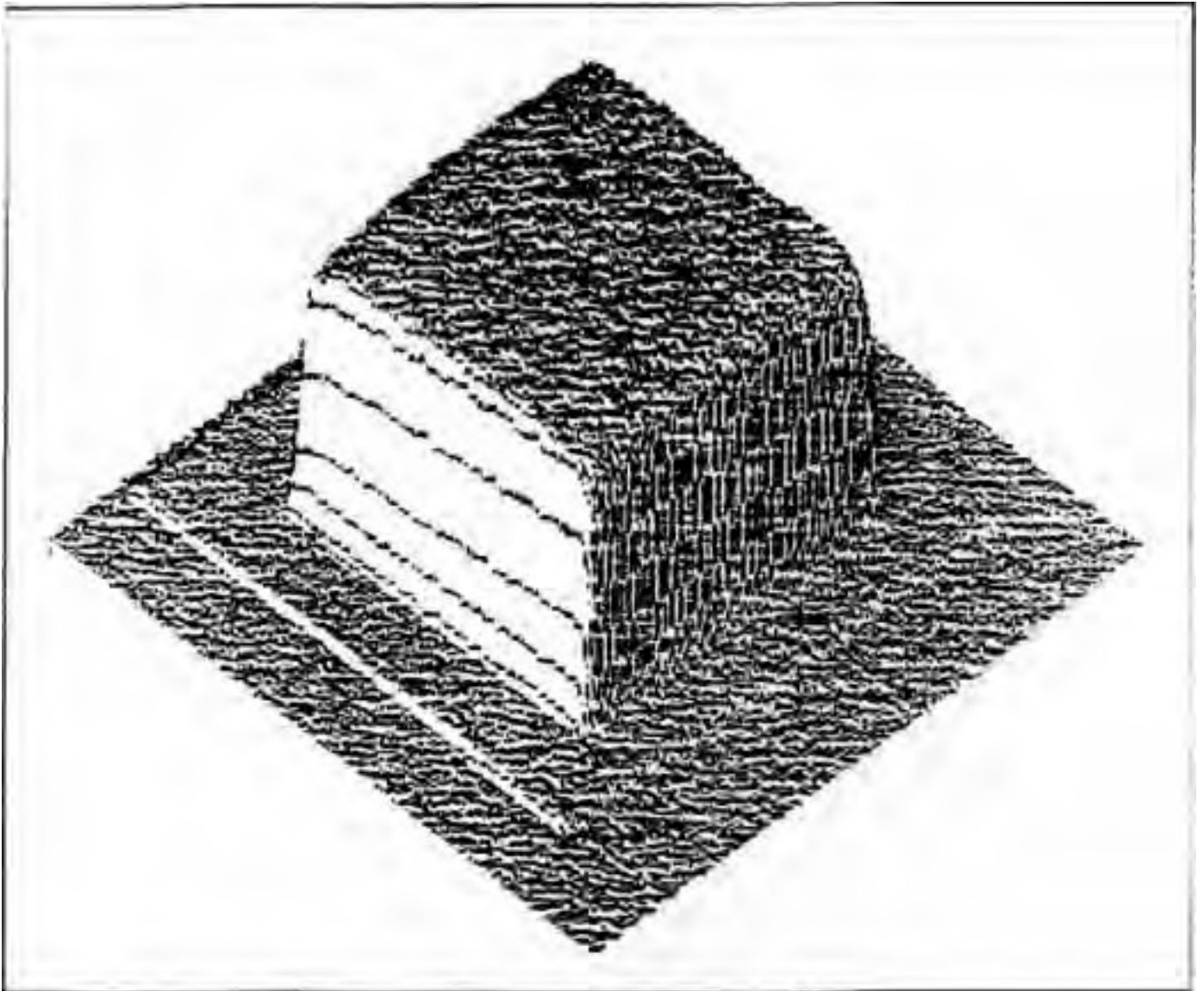

Figure 8



Beam profile of a $5 \times 5 \text{ mm}^2$ illumination field

Figure 9

BUDGET

YAG laser for use with Excimer	\$49,700 00
Excimer	\$90,000 00
Gasses and Cabinets	\$5000 00
JR laser safety glasses (four pair)	\$900 00
power meter and filters	\$2995 00
lenses and optical mounts	\$3400 00
HeNe laser	\$1280 00
CCD camera and video monitor	\$5975 00
Computer with CD ROM and frame grabber	\$4500 00
JR viewer	\$144000
Optical bench	\$900 00
Laboratory mounts and tracks for art	\$1000 00
Spectrometer	\$12,000 00
PDA multichannel analyzer	\$1500000
Outside Analytical Services	\$7500 00
Travel	\$4000 00
Salary	\$55,000 00
Air Handling Equipment	<u>\$10,000 00</u>
	\$270,590 00

BUDGET

Single system YAG laser	\$83,370 00
JR laser safety glasses (four pair)	\$900 00
power meter and filters	\$2995 00
lenses and optical mounts	\$1400 00
HeNe laser	\$1280 00
CCD camera and video monitor	\$5975 00
Computer with CD ROM and frame grabber	\$4500 00
IR viewer	\$144000
Optical bench	\$900 00
Laboratory mounts and tracks for art	\$1000 00
Spectrometer	\$7000 00
PDA multichannel analyzer	\$15000 00
Outside Analytical Services	\$7500 00
Travel	\$4000 00
Salary	\$55,000 00
Air Handling Equipment	<u>\$10,000 00</u>
	202,260 00