

## U.S. M1892 Magazine Rifle (Krag-Jorgensen), Caliber .30-40 Army

The first bolt-action, magazine-fed, smokeless powder rifle adopted by the U.S. Army as a primary shoulder arm in 1892. A model manufactured at the Springfield Armory patterned on the Norwegian design of Ole Krag and Erik Jorgensen. The repeating rifle replaced the single-shot .45-70 Springfield Rifle introduced in 1873, known as the "Trapdoor" from its hinged-breech mechanism. Chambered in .30 caliber with 40 grains of cordite (smokeless) powder propellant, the "Krag" as it was known, was loaded from a side box, rotary magazine that held five cartridges. A manual cut-off mechanism allowed single loading of cartridges into the chamber from the open breech, while reserving a full magazine. The magazine could also be reloaded with the bolt closed by opening the hinged plate on the side box magazine and charging with cartridges. The Krag fixed a knife-blade bayonet to a slotted mount beneath the muzzle.

The Krag saw service for about a decade, in the Spanish-American War, the Boxer Rebellion, and the Philippine Insurrection. Replaced by the M1903 Springfield (patterned on the Mauser) Rifle, Krags were still issued to National Guard and Reserve troops.



## Parts Legend

- A. Firing pin assembly
- B. Safety lock
- C. Sleeve
- D. Extractor rivet
- E. Extractor
- F. Mainspring
- G. Striker
- H. Bolt
- I. Bolt assembly
- J. Cutoff
- K. Side-plate screw
- L. Side-plate
- M. Ejector
- N. Ejector pin
- O. Barrel and receiver assembly
- P. Hinge bar
- Q. Gate
- R. Magazine spring
- S. Carrier and follower assembly
- T. Sear spring
- U. Sear
- V. Trigger pin
- W. Trigger
- X. Front band
- Y. Carbine stock Mod. 1896 ass'y
- Z. Handguard
- AA. Trigger guard
- BB. Front guard screw
- CC. Rear guard screw

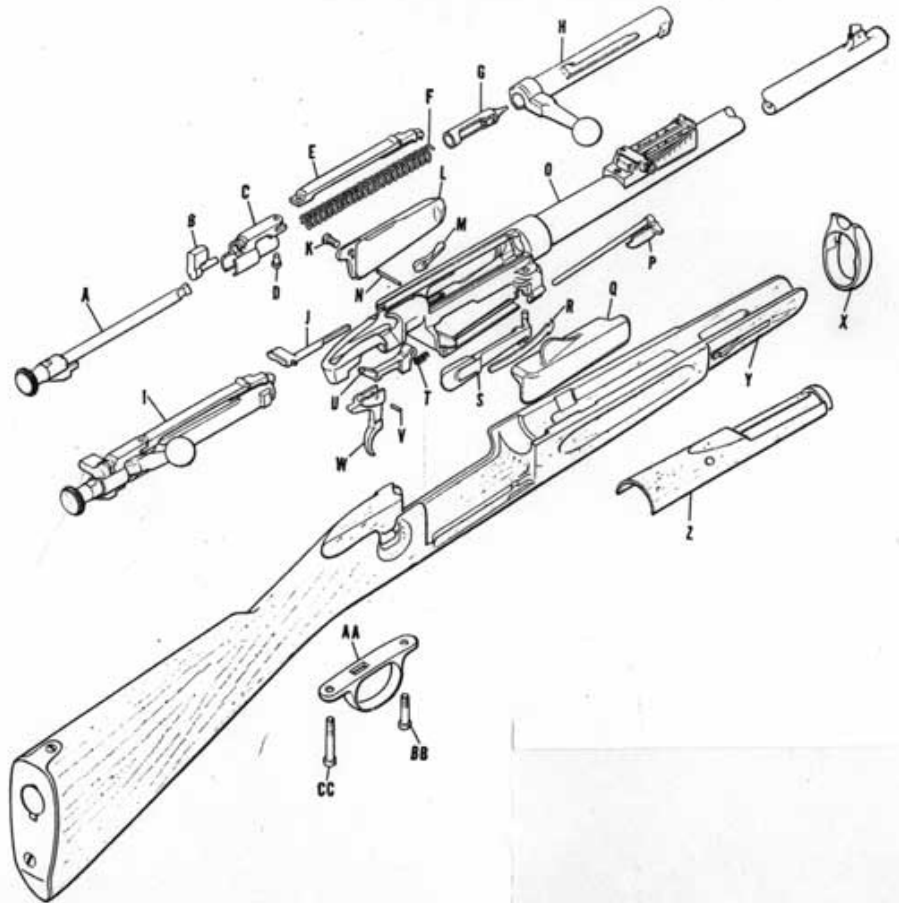

**Krag-Jorgensen  
Model 1892-99 Rifle**

- |                       |                                  |
|-----------------------|----------------------------------|
| 1 Bolt Body           | 19 Magazine Spring               |
| 2 Extractor           | 20 Carrier and Follower Assembly |
| 3 Bolt Sleeve         | 21 Sear Spring                   |
| 4 Extractor Rivet     | 22 Sear                          |
| 5 Safety              | 23 Trigger Pin                   |
| 6 Firing Pin Assembly | 24 Trigger                       |
| 7 Mainspring          | 25 Rear Guard Screw              |
| 8 Striker             | 26 Trigger Guard                 |
| 9 Ejector Pin         | 27 Front Guard Screw             |
| 10 Ejector            | 28 Magazine Gate                 |
| 11 Bolt Assembly      |                                  |
| 12 Magazine Cutoff    |                                  |
| 13 Sideplate Screw    |                                  |
| 14 Sideplate          |                                  |
| 15 Receiver           |                                  |
| 16 Barrel             |                                  |
| 17 Front Sight        |                                  |
| 18 Hinge Bar          |                                  |

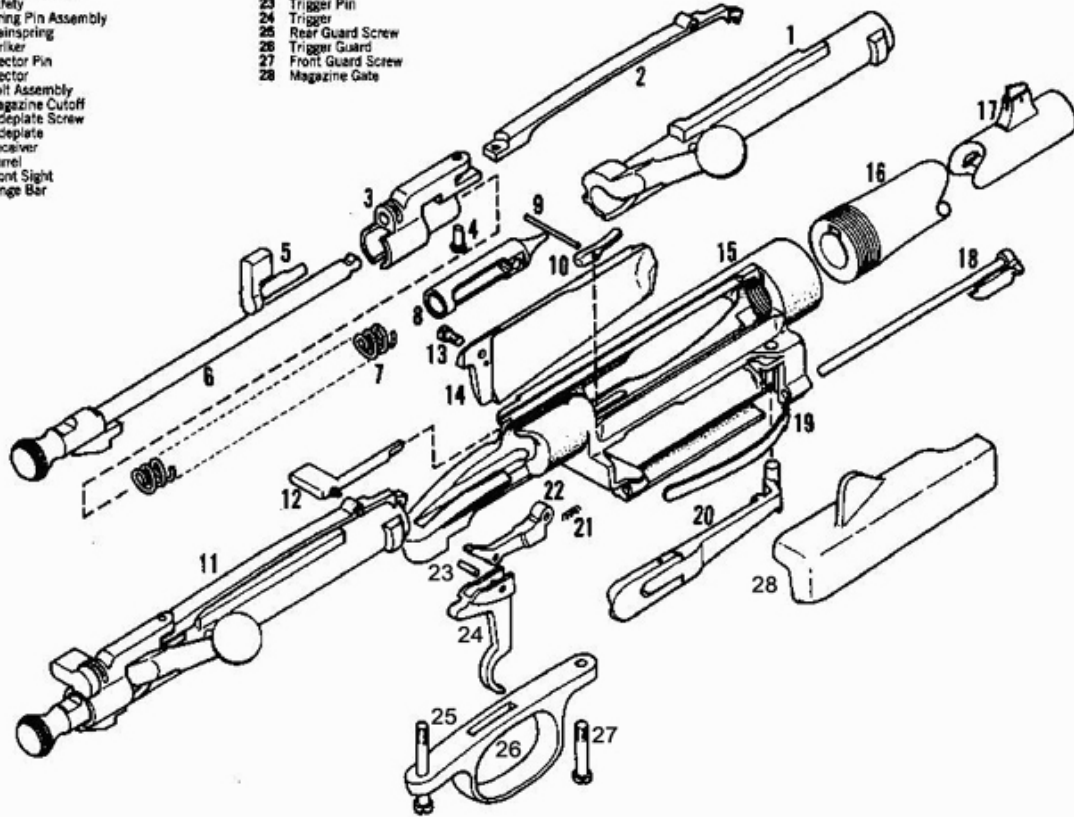

1. Cocking Piece.    2. Bolt.    3. Loading Gate.    4. (Fore)stock.    5. Upper Band.    6. Front Sight

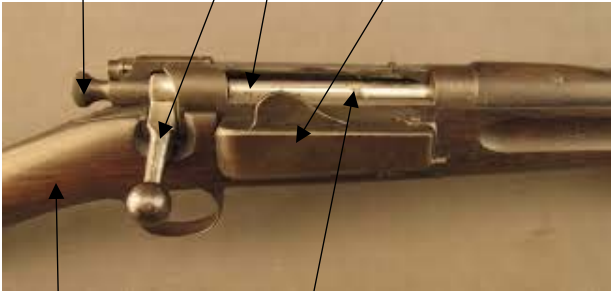

7. Small of Stock.    8. Receiver.

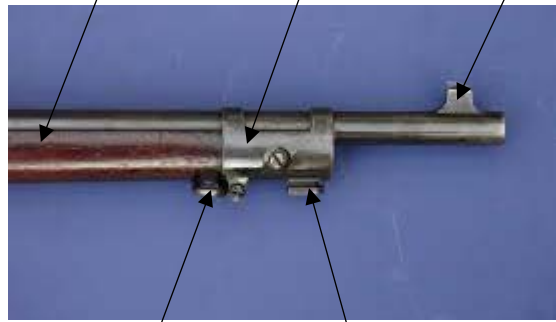

9. Stacking Swivel.    10. Bayonet Stud.



11. Side Plate. 12. Magazine Cut Off. 13. Safety Lock. 14. Thumb Piece.  
15. Comb of Stock. 16. Rear Sight. 17. Lower Band Sling Swivel.



18. Bayonet Pommel. 19. Grip. 20. Guard.



**M1899 Springfield Krag Carbine**

## Manual of Arms



**Inspection, Arms.** Lift piece with left hand, keep muzzle raised and oriented in safe direction, examine safety, and open bolt to expose breech and chamber with right hand. Open loading gate to expose magazine with right hand. Visually insure piece is unloaded. Close loading gate to secure magazine; shut bolt to close breech, and grasping cocking piece at comb with right thumb to relieve tension, pull trigger to release firing pin on empty chamber. Piece to remain diagonal across body, muzzle elevated safely during inspection.

**Order, Arms.** Grasp piece with right hand above magazine, and lower butt to ground to rest heel plate even with right toe, barrel to rear, trigger guard to front, bolt and magazine facing to right. Piece held upright by right hand, fingers and thumb clasping the stock with thumb and last two fingers to rear along barrel, first two fingers to front along stock. Muzzle at height of elbow or cartridge belt. Piece held straight and perpendicular to ground, close to body. Left arm lowered to side to rest naturally against body.



**Shoulder, Arms. First Position.** Grasp piece with left hand above magazine and lift diagonally across body with magazine to front and barrel sloping upward to left. Grasp butt

with right hand with thumb and fingers clasped around stock, heel plate between first two fingers. Piece held near body, with left forearm resting against chest.

**Second Position.** Transfer piece across body with left hand to right shoulder. Muzzle sloping upward to rear. Right hand grasps butt. Left hand quits piece to touch the rifle opposite the bolt handle, fingers joined and extended.

**Third Position.** Right hand grasps piece at butt, trigger guard in hollow of right shoulder, rifle sloped slightly to rear resting on right shoulder. Left arm dropped to side to hang naturally against body.

**Order, Arms.** Lower piece with right hand from shoulder, while raising left arm to grasp piece and turn it to the front, quitting piece with right hand from butt to re-grasp piece with same hand around barrel and fore-stock, and lower butt to ground, heel of butt near toe of right foot, trigger guard to front. Left arm lowered to side to rest naturally against body.

**Present, Arms. First Position.** Piece raised and brought before body by right hand, left hand grasps piece at balance of the stock, thumb extended along stock. Barrel vertical and to rear, rifle held close to body.

**Second Position.** Quit piece with right hand to re-grasp at small of stock.

**Order, Arms.** Quit piece with right hand from small of stock, while grasping with left at balance of piece, re-grasp with right hand above left, and quitting piece with left hand, lower rifle to right side to rest butt on ground with right hand, and drop left arm to side.

**Port, Arms.** Lift piece with right hand, bringing it diagonally across body, magazine to front. Grasp piece with left hand at balance of stock, thumb clasped around stock to rear, re-grasp piece with right hand at small of stock. Barrel slopes upward and to left, rifle held close to body across chest.



**Order, Arms.**

**Parade, Rest.** Right hand turns piece to left across body, magazine and bolt to rear, muzzle held upward, barrel to left. Butt placed before right foot, which is drawn six inches to rear. Left knee slightly bent. Left hand grasps piece above right hand, just below stacking swivel. (Bayonet can be fixed or unfixd at parade rest.)



**Order, Arms.**

**Inspection, Arms.** Lift piece with right hand as in port, grasping balance of stock with left hand. Open bolt and magazine to expose chamber and breech. Re-grasp piece at butt with right hand, heel between first two fingers. Rifle held diagonally across body, barrel elevated and sloped to left, piece close to body. Thrust rifle slightly forward when inspector reaches for piece. Take rifle back into inspection position from inspector, close bolt and magazine, release tension on firing pin by grasping cocking piece at comb and pulling trigger with right hand.

**Order, Arms.**

**Fix, bayonet. First Position.** Move piece to position of parade, *rest* with butt in front of right foot, foot withdrawn six inches to rear. Magazine and bolt to rear. Left hand grasps piece around barrel and stock just below stacking swivel. Right hand grasps hilt of bayonet on left waist with back of hand towards body. Draw bayonet from scabbard.

**Second Position.** Fix bayonet on barrel, engaging barrel ring on guard over muzzle, inserting mortise on bayonet pommel and along grip into bayonet stud on upper barrel band, and engaging bayonet catch nut on bayonet pommel to lock bayonet to rifle. Fixing the bayonet is accomplished with a sliding motion. Rifle is held vertically before body, left hand grasping piece and right hand around bayonet fixed on muzzle.

**Order, Arms.**

**Charge, bayonet.** Lift piece with right hand grasping rifle at balance of stock. Half face to right, with right heel six inches to rear and three inches to right of left heel. Bayonet held at height of chin.

**Order, Arms.**

**Unfix, bayonet.** Move piece before body as in fix, *bayonet*. With right hand depress the bayonet catch nut, grasping bayonet around hilt or grip. Release and draw bayonet from muzzle, and sheathe in bayonet scabbard with right hand, while supporting piece with left hand grasping piece below stacking swivel.

**Order, Arms.**

**Secure, Arms.** Lift piece with right hand and steadying with left, turn piece so barrel faces down, raising rifle so trigger guard is in right armpit, barrel sloping downward. Quit piece with left hand to rest at left side, right hand supports piece at balance of stock, thumb along groove in hand guard, fingers clasping piece around inverted barrel.

**Order, Arms.** Raise piece with right hand, steadying with left, as rifle is turned with barrel to rear, and held vertically before lowering with right to rest butt on ground at right foot.

**Load.** Lift piece with right hand, bringing rifle to right side, grasping piece with left hand at balance of stock. Half face to right, bringing right heel six inches to the rear and three inches to right of left heel. Muzzle at height of chin, barrel held upright and pointed safely downrange. Open magazine with right hand, and draw cartridges from loops on Mills belt to load into magazine (or open catch on McKeever cartridge box, and draw cartridges from woven loops within box to charge magazine). Shut magazine. **To Fire.** Draw bolt back with right hand working action to chamber a round. Grasp piece at small of stock with right hand. Safety catch can be engaged before firing. Cut off switch can be engaged to reserve full magazine, and load with single cartridges. Keep finger away from trigger.

**Aim. (Standing).** Lift piece to right shoulder, butt into armpit. Grasp piece with left hand at magazine. Right elbow at height of shoulder; left elbow against body. If engaged, click safety catch down to fire. **Fire.** Place finger on trigger and squeeze to discharge piece. To reload, work bolt and chamber fresh round. Fire until magazine empty, or reserve cartridges, but only if safety catch engaged. Load and aim can also be performed from a kneeling or prone position.





**Inspection, Arms.** Examine piece to assure it is unloaded after firing. Collect ejected shell casings.

**Order, Arms.**

**Trail, Arms.** Lift piece with right hand, grasping piece above balance of stock. Right arm slightly bent, incline piece to front slightly, muzzle upward. Left arm at side.

**Order, Arms.**

**Sling, Arms.** Lift piece with right hand at right side, grasping rifle with left hand at balance of stock. Quit piece with right hand and re-grasp at small of stock. Lift rifle vertically and turn barrel out to front. While steadying piece with left hand, quit piece with right, and slip right arm through sling. Seat slung rifle on right shoulder, muzzle down, barrel to rear. Quit piece with left hand and steady piece with right hand along fore stock, dropping left arm naturally to left side.

