

D-871 C
File:
NPS General

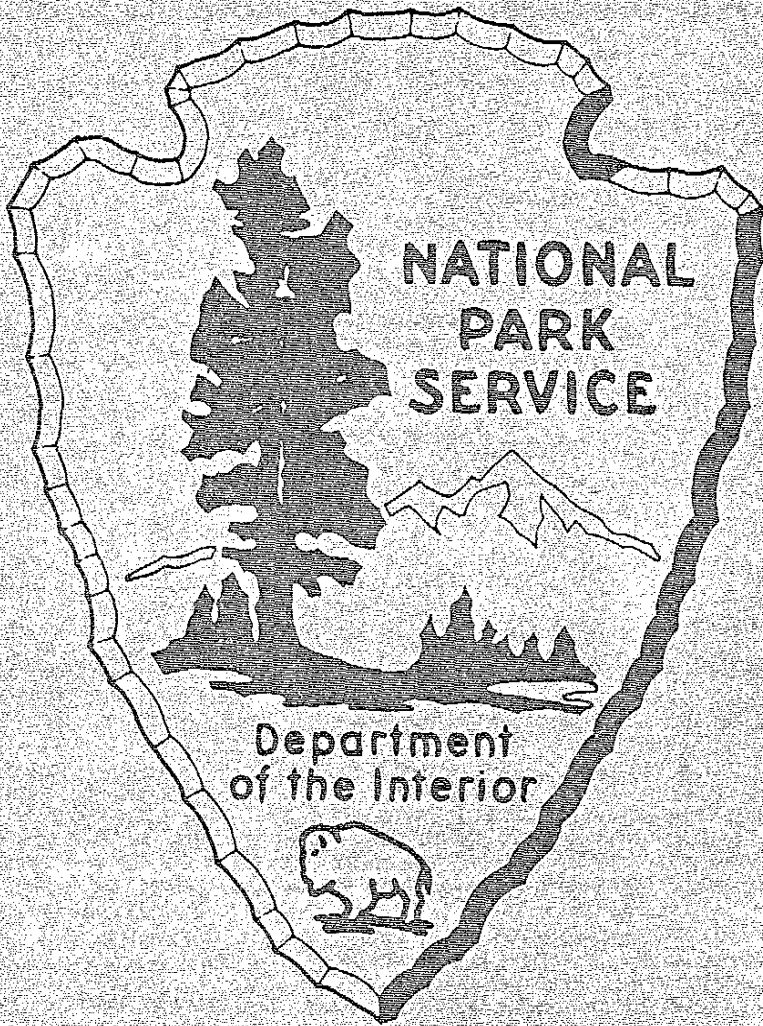

SIGN MANUAL

SCANNED

9/29/00

PLEASE RETURN TO:
TECHNICAL INFORMATION CENTER
DENVER SERVICE CENTER
NATIONAL PARK SERVICE
JANUARY 1988

ON MICROFILM

NATIONAL PARK SERVICE

SIGN MANUAL

Revised - January 1988

UNITED STATES DEPARTMENT OF THE INTERIOR

TABLE OF CONTENTS

Chapter 1	Purpose and Applicability
Chapter 2	Resource Documents
Chapter 3	Planning Considerations, Park Sign Plans and Inventories
Chapter 4	General Functions and Categories of Signs
Chapter 5	Rules for Formulating Sign Size and Text
Chapter 6	Specifications for Manufacture of Signs
Chapter 7	Procurement of Signs and Related Material
Appendix A	Letter Styles
Appendix B	Sign Plan Outline
Appendix C	Sample Sign Plan
Appendix D	Specifications for Colors
Appendix E	User Inserts

CHAPTER 1: PURPOSE AND APPLICABILITY

PURPOSE

This Sign Manual replaces the October 1978 edition of the National Park Service Sign System Specifications (NPS-SSS). It is designed for use by Park managers as an aid to the implementation of the National Park Service Traffic Control Sign System Guideline (NPS-52) and in arriving at management decisions regarding other park signing needs. It is intended that Park managers will utilize this Manual as a guide in the designing and ordering of all vehicular and pedestrian traffic control signing and other pertinent devices.

This Manual constitutes the official National Park Service supplement to the Manual on Uniform Traffic Control Devices (MUTCD) published by the Federal Highway Administration, U.S. Department of Transportation. Together, the MUTCD and this Manual are utilized by the National Park Service to provide for park managers recommended standards, specifications and procedures for the NPS Sign System to assure a uniform and distinctive system of signing and graphics in meeting the Service's obligations under Public Law 89-564, the Highway Safety Act of 1966, and the Highway Safety Program Standards 23 USC 402, in a manner consistent with National Park Service missions.

APPLICABILITY

Long established and documented National Park Service policy [**Park Road Standards** (1968 and 1984)] holds that park roads have a unique purpose, which differs significantly from the purpose of roads on the Federal and state highway systems. The **Park Road Standards** contain the following admonishment to park visitors:

Park roads are for leisurely driving only. If you are in a hurry, you might do well to take another route now, and come back when you have more time.

Signing on all park roads should be consistent with National Park Service policy that park roads are not intended to provide fast and convenient transportation, nor designed or intended to serve as commuter routes or connecting links to the Federal and state highway systems. Rather, they are intended to enhance the park experience while providing safe and efficient accommodation of park visitors.

In this regard, the MUTCD in conjunction with this NPS Sign Manual, should be utilized by Superintendents as guidance in making management decisions on the design, location, and application of road signs and markings on park roads; and it is the policy of the National Park Service to follow the MUTCD with respect to the format of all regulatory signs installed on NPS roads open to public vehicular traffic.

Nevertheless, the individual park manager, following the guidelines and procedures set down in NPS-52, has the responsibility for determining whether or not a sign is necessary or appropriate at a given location. The decision to utilize a particular sign at a particular location requires the professional judgment of the park manager--drawing upon available guides, resources, and traffic safety engineering expertise--and considering a variety of other factors, such as the appearance of the road as a whole and its relationship to the natural and/or historical environment through which it passes.

It is important in this regard, too, that such decisions bear in mind long standing NPS policy to minimally intrude upon the natural or historic setting in National Park System areas, and to avoid an unnecessary proliferation of signs, while striving to ensure for the safety of park visitors.

Through an agreement with the Federal Highway Administration, the National Park Service has developed several specific exceptions to specific sections of the MUTCD, as follows:

Section 2A-27 Posts and Mountings

Add: Timber sign supports: A soil mounted timber sign support is acceptable as a breakaway support if it has a uniform cross section of not more than 24 square inches, or if within an 8-foot width path, there are:

Two posts, each no larger than 3" x 6" or 4" x 5" dimension stock, or round posts no larger than 5" diameter, or 15¾" circumference.

Three posts, each no larger than 3" x 5" or 4" x 4" dimension stock, or round posts no larger than 4½" diameter or 14" circumference.

Section 2D-3 Color, Reflectorization, and Illumination

Add: Brown shall be the background color for all guide signs on National Park Service roads except for detour markers, detour signs, arrows, route markers, markers, or assemblies indicating a junction or intersection with an interstate highway.

Section 2D-5 Lettering Style

Add: Modified Clarendon lettering shall be used on all National Park Service guide and informational signs.

Example of letter style is shown in Appendix A.

Section 2D-6 Size of Lettering

Add: The size of lettering required for guide signs is directly a function of design speed. Die-cut letter fonts for the Modified Clarendon style are available in 3.75", 6", 9", and 12" capital heights. Corresponding lowercase sizes are two-thirds the capital height. Minimum standards for use of these letters are shown in Chapter 5 of this Manual.

Section 2D-7 Amount of Legend

Detailed guidelines for determining sign size and text are found in Chapter 5 of this Manual.

CHAPTER 2: RESOURCE DOCUMENTS

The following documents are available from the Superintendent of Documents; U.S. Government Printing Office; Washington, D.C. 20402.

Manual on Uniform Traffic Control Devices (FHWA)

Traffic Control Devices Handbook (FHWA)

Work Zone Traffic Control, Standards and Guidelines (DOT)

Standard Highway Signs Book (FHWA)

Standard Specifications for Construction of Roads and Bridges on Federal Highway Projects (FP-85) Sections 633 and 718 (FHWA)

National Park Service Park Road Standards

The "NPS Traffic Control Sign System Guideline (NPS-52)" is available from the National Park Service; Engineering and Safety Services Division; Washington, D.C. 20013-7127.

The following documents are available from the U.S. Department of Transportation; Federal Highway Administration, (HTO-21); Washington, D.C. 20590.

Standard Alphabets for Highway Signs (FHWA)

Specifications for Standard Highway Sign Colors (FHWA)

The "Transportation and Traffic Engineering Handbook" is available from the Institute of Transportation Engineers; 525 School Street, S.W.; Washington, D.C. 20024.

The "Traffic Engineering for Better Signs and Markings" is available from the Military Traffic Management Command; Transportation Engineering Agency; ATTN: MTT-TE; P.O. Box 6276; Newport News, Virginia 23608.

The following documents are available from U.S. Department of Agriculture; Forest Service; Equipment Development Center; Missoula, Montana 59801.

Anti Sign Theft and Vandalism Guide (USFS)

Signs Maintenance Guide (USFS)

Placement Guide for Traffic Control Devices (USFS)

The following documents are available from the U.S. Department of Transportation; Federal Aviation Administration; 800 Independence Avenue, S.W.; Washington, D.C. 20591.

Taxiway Guidance Sign System AC150/5340-18A (DOT)

Markings of Paved Areas on Airports AC150/5340-1E (FAA)

The "Uniform State Waterway Marking System" is available from the U.S. Department of Transportation; Coast Guard; 400 7th Street, S.W.; Washington, D.C. 20590.

Individual states may have their own state supplements to the MUTCD.

CHAPTER 3: PLANNING CONSIDERATIONS, PARK SIGN PLANS AND INVENTORIES

ENGINEERING STUDY REQUIREMENTS

The decision to use a particular traffic control device at a particular location should be made on the basis of an engineering study of the location. Thus, while this Manual and the MUTCD provide guidance and standards for design and application of traffic control devices, they are not a substitute for engineering judgment. It is the intent of these Manuals to make available to Park Managers currently accepted practices and standards for traffic control devices and their installation. Qualified engineers are nevertheless needed to exercise the engineering judgment inherent in the selection of traffic control devices for a particular site, just as they are needed to locate and design the roads and streets which the devices complement. Those areas which do not have qualified engineers on their staff should seek assistance from the Regional Office, WASO Engineering and Safety Services Division, Denver Service Center, Federal Highway Administration, local or state highway departments, the county, a nearby city, or a traffic engineering consultant.

PLANNING CONSIDERATIONS

To assist the Park Sign Committee, some consideration and guidelines for preparing signs - texts, layout, and size - as well as methods for selecting appropriate sites are suggested. In determining the need for any sign or marker, the following questions should be answered:

1. What does the visitor need to know?
2. Is guidance or a message needed?
3. If so, where is a message needed?
4. What message is needed?
5. How shall the message be presented (sign, symbol, exhibit, audio, or other means)?
6. Is the sign for drivers of vehicles, pedestrians, or both?
7. At what speed is the visitor traveling?

Before proceeding with a sign, the answers to the above questions should be tested on several people not immediately concerned with the particular sign under consideration.

To be effective the sign must:

1. Fulfill a need.
2. Command the attention and respect of user.
3. Convey a clear simple message.
4. Give adequate time for proper response.

To fulfill these requirements, five basic considerations should be made:

1. *Uniformity.* Similar situations are treated in the same way. Uniformity of traffic control devices simplifies the driver's task of recognizing, understanding, and reacting. It helps the National Park Service through economy in manufacturing, maintenance, administration, and recognition by the users that they are in the National Park System. Simply using uniform traffic control devices does not in itself constitute uniformity. A standard uniform device used where it is not appropriate is as objectionable as a nonstandard device; in fact, this may be worse because misuse breeds disrespect of all devices.

2. *Design.* The device should assure that features such as size, contrast, color, shape, composition, and lighting or reflectorization are combined to draw attention to the device; that shape, size, color, and simplicity of message produce a clear meaning; that legibility and size combine with placement to permit adequate time for driver response.

3. *Placement.* This assures that the device is within sight of the user so that it will command attention, and is such that a driver traveling at normal speed has enough time to safely make the proper response.

4. *Operation.* The right device must be installed to meet the traffic requirements at a given location; it must be placed in a uniform and consistent manner so motorists will properly respond to the device, based on their previous exposure to similar traffic control situations.

5. *Maintenance.* Devices must be maintained to a high standard to assure that legibility is retained, that the device is visible, and that it is removed if no longer needed.

Design and placement of signs on park roads must be compatible with vehicle speed, traffic pattern, and the driver's visual perception responses.

1. As speed increases, driver concentration increases.
2. As speed decreases, driver concentration recedes. At 25 mph, the natural eye focus point lies 600 feet ahead of the car; at 45 mph it lies 1,200 feet ahead of the car.
3. As speed increases, the driver's peripheral vision decreases. More horizontal clearance is possible in sign placement on low speed roads.
4. As speed increases, foreground details begin to fade. At 40 mph the closest point of clear vision lies 80 feet ahead of the car. At 60 mph the driver can see clearly only that detail within an area 110 to 1,400 feet ahead of the car and within an angle of 40 degrees. At that speed, the distance between 110 and 1,400 feet is traveled in less than 15 seconds.

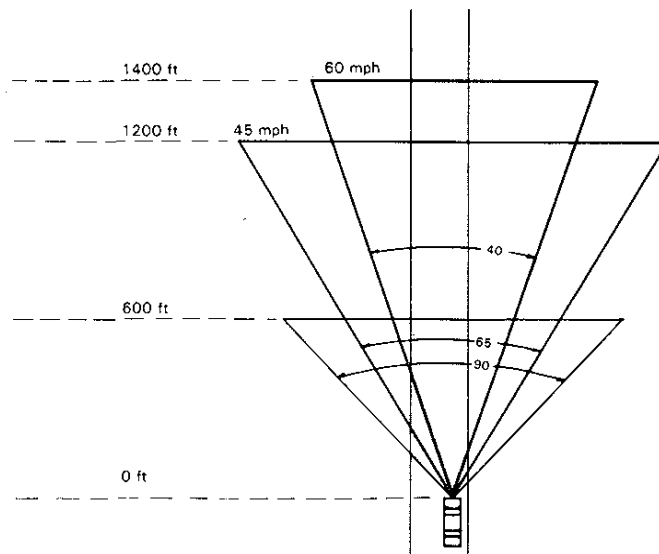

DRIVER'S VISUAL PERCEPTION RESPONSES

SIGN PLAN AND INVENTORY

The National Park Service "Traffic Control Sign System Guideline, NPS-52" require that each Park have a current sign plan and inventory. The Park Sign Plan establishes the role of all signs in carrying out the Park's objectives. Signing must relate to all transportation modes, providing information, direction and traffic control for the benefit of the visitor's safety. References for the preparation of this plan includes the various Park planning documents, including the Interpretive Prospectus and Wayside Exhibit Plan, manuals and data as appropriate. A sample sign plan and information helpful to its preparation are included in Appendix B and Appendix C. The plan should address four major planning concerns.

1. Descriptive Narrative

This material should be brief, delineating the purpose of the plan as it relates to the mission of the Park, its resources, and the presentation of this mission and purpose to the visitor.

2. Sign Survey and Inventory

The sign survey and inventory should identify the effectiveness of the existing signing and serve as a maintenance document. It should include type, location, description, text, installation data, condition, and initial cost. There should be room to include data for repairs made and when, inspections made and conditions recorded and recommended changes for replacement signs. Photographs of all informational, directional, interpretive and other unique signs are recommended for inclusion with the inventory for reference when replacements are needed or when changes in text are being considered.

3. Location Plan

This section contains drawings showing existing and proposed locations, message and orientation for proposed signs. The existing locations also identify inventory and photograph numbers.

4. Summary

This section outlines the general function of the plan and how it is integrated into the other area management, operations, and safety practices.

Review and Approval Process

The following flow chart illustrates review and approval process for the Park Sign Plan from preparation by the Park Sign Committee, through the Superintendent to the Region for approval. After approval, the Regional Director returns the plans to the Park for implementation:

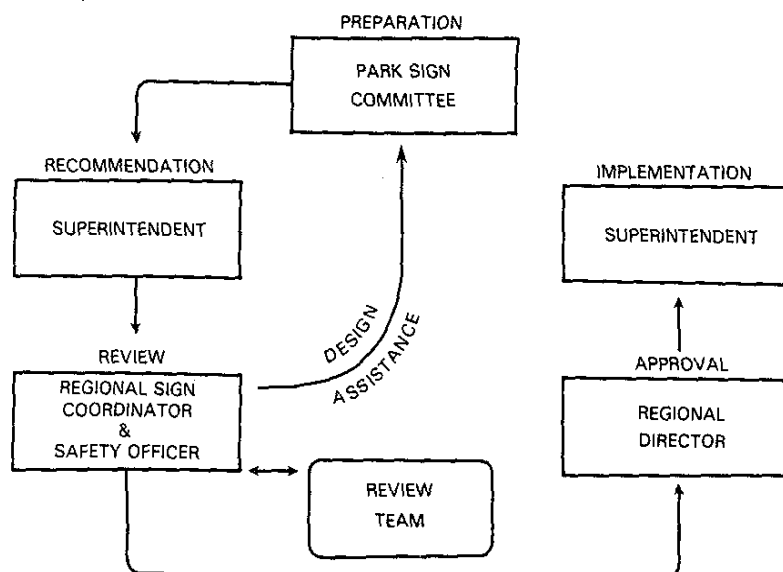

Annual Inspection, Review and Sign Plan Update

The Park Sign Committee will conduct an annual inspection of signs and review the Park Sign Plan. This critical inspection and review provides an opportunity to keep park signs current, and to update the Sign Survey and Inventory. Inspections shall be made both in daylight and at night. Any revisions to the Sign Plan should also be prepared at this time and submitted to the Region as an appendix to the approved plan, or as revised substitute pages. If revisions are extensive the review and approval process may be required.

Sample Forms

The following forms,

- 10-47 Sign Survey and Inventory - 1 (Descriptive Data), and
- 10-48 Sign Survey and Inventory - 2 (Historical Data)

may be used to establish an initial inventory or to supplement an existing inventory system. The instruction which follow may be used to complete these forms. An alternate approach may be to use the 10-84 series sign requisition forms to establish a park sign inventory. These forms do not, however, provide sign location data or post details. If 10-84 series forms are selected for your park sign inventory, an option worth considering would be to photocopy the 10-48 Historical Data form or something similar on the back of each form. In this way the descriptive information and maintenance record for each sign would be on one page.

Instructions

The following is a list of codes for use in completing Forms 10-47 and 10-48. The codes are in the same sequence as contained on the respective forms, reading from left to right.

All columns should be completely filled out. For those columns for which no information is available, fill in the spaces with "zeros".

Completed forms may be maintained and organized in any system considered best by the individual park or area.

The conventional rule on the use of digits and numbers on ADP forms will apply, i.e., the "unit" number, the last entry of a number or code, will be placed in the extreme right-hand box of the spaces provided for that code.

Example: MUTCD sign M4-9L would be coded OOM49L. The extra zeros are added to fill in columns for which no other data entry is available.

FORM 10-47

Sign Number

Each sign shall be assigned a five-digit number. The first three digits shall be the route number assigned during the Road Inventory and Needs Study (RIP) and as shown on the area or route maps of the RIP reports. The remaining digits shall be unique to the individual sign.

Examples: 01143 - sign number 43 on Route 11.

The numbers assigned shall be used consistently in all reports. Sign numbers should be stamped unobtrusively on the back of each sign for field inventory, and possible identification in theft recovery.

Area

Park

This entry will be a five digit number consisting of a zero followed by the park organization code as presently prescribed, e.g. 05170 for Guilford Courthouse National Military Park, or 09500 for Olympic National Park.

Operation (OP) Unit

The division or operation unit in which the sign is located.

Type

Code

RG	Regulatory
WA	Warning
IF	Information
DM	Destination (Direction & Mileage)
IN	Interpretive
EN	Entrance
PM	Plaques & Markers
NP	NPS Emblem
ST	Statuary
RM	Route Marker
XX	Other

Manual Numbers

Manual numbers refer to the MUTCD numbers assigned to symbol, warning and regulatory signs in the latest edition of the MUTCD or *Standard Highway Signs Book*.

Fund

Not to be used

Location

Road

Route: The route number assigned during the Road Inventory Program.

Mile: The mileage shall be determined by established mile posts, if available, or by certified odometer reading to the nearest $\frac{1}{10}$. Roads shall be surveyed west to east and south to north. Beginning points and mileage shall be consistent with Road Inventory data.

Direction (DIREC)

The direction or nearest direction the sign faces: N-North; E-East, S-South, W-West.

Description

Size

Sign: Code as shown for given sign size.

01	6 x 6 to 36 x 36 (Informational Signs Only)
02	42 x 38 to 54 x 46
03	60 x 48 to 114 x 60
04	120 x 62 to 150 x 90
09	Standard size Regulatory or Warning sign, as specified in MUTCD.

Letter:

01	12" uppercase/8" lowercase height (oversize category 1)
02	9"/6" (categories 1, 1A)
03	6"/4" (category 2)
04	3.75"/2.5" (category 3)
05	2.25"/1.5" (category 4)
06	1.5"/1.0" (category 5)
07	1.0"/.67" (category 5A)
08	Other (Informational signs only)
09	Standard letter size specified in MUTCD for the appropriate Regulatory or Warning sign.

Color: Background (BACK) and Letters (LTR): Use these codes for both background and letters.

RD	Red
WH	White
GR	Green
BR	Brown
BL	Blue
YE	Yellow
BK	Black
OR	Orange
GB	Grey-Blue
XX	Other

Materials

Post:

01	Steel Channel or U
02	Wood 4" x 4" or 4" x 6"
03	Wood 6" x 6" or larger (breakaway only)
04	Steel Pipe
05	Concrete
06	Light Pole
07	Aluminum
08	Weathered Steel Tubing, 2" x 2" with Breakaway Mount
09	Weathered Steel Tubing, 4" x 2½" with Breakaway Mount
10	Weathered Steel Tubing, 6" x 4" with Breakaway Mount
XX	Other

Face: Codes apply to surface material only.

01	Reflective Sheeting, (FP 85, Type III)
02	Reflective Sheeting, (FP 85, Type II)
03	NonReflective Sheeting
04	Reflective Paint
05	Beads on Paint
06	NonReflective Paint
07	Reflector Buttons
08	Unpainted Wood
09	Anodized (Aluminum)
10	Unpainted Metal
XX	Other

Back: Sign material, or backing upon which facing is mounted.

01	Aluminum (not routed)
02	Plywood
03	Other Wood
04	Steel
05	Routed Aluminum
06	Plastic
07	Steel Plate
08	Stone or Monument
09	Embossed Steel
XX	Other

TEXT - (Wording of Sign)

Print or type sign text or graphics as it appears on the sign, using a slash to separate each line of the message. Use only one line of form 10-47, leaving off what cannot be included on that line. This area may also be used to identify photo number if text does not fit.

FORM 10-48

Fiscal Year (FY)

Space is available to record maintenance data for three consecutive years.

Sign Number

Code as described under "Sign Number" section, SIGN SURVEY AND INVENTORY, 1-(Descriptive Data).

Date Installed

Code shall be a four-digit number. The first two digits shall be the month, and last two digits shall be the last two digits of year.

Month:

01	January
02	February
03	March
04	April
05	May
06	June
07	July
08	August
09	September
10	October
11	November
12	December

Year:

86	1986
87	1987
88	1988
89	1989
etc.	

(Example: January 1986 would be 0186.)

Installation Cost

Include costs of manufacturing, shipping and installing the sign.

01	\$0-25
02	26-50
03	51-75
04	76-100
05	101-200
06	201-300
07	301-400
08	401-500
09	501-600
10	601-700
11	701-900
12	1000 +
13	No cost to NPS

Condition Codes

Post-Condition

01	Satisfactory
02	Not Straight
03	Needs Painting
04	Deteriorated
05	Needs Straightening & Painting
06	Warped (wood)
XX	Other

Face-Condition

01	Satisfactory
02	Defaced
03	Corroded
04	Mounting Loose
05	Faded
06	Not Legible
07	Warped (wood)
08	Deteriorated
09	Paint Peeling
10	Reflective/Nonreflective/Peeling
XX	

Letters (LTRS)-Condition

01	Satisfactory
02	Defaced
03	Faded
04	Not Legible
05	Paint Peeling
06	Reflective/Nonreflective/Peeling
XX	Other

Reflectivity (REFL)-Condition

01	Excellent
02	Good
03	Fair
04	Poor
05	Nonreflective

Visibility (VISIB)-Condition

01	Can be seen easily
02	Hidden by official sign
03	Hidden by advertising sign
04	Hidden by brush
05	Hidden by tree limbs
06	Hidden by parked vehicles
07	Hidden because of curve
08	Hidden because of hill
09	Hidden because of building
XX	Other

Maintenance Cost (Maint. Cost)

01	No Cost
02	\$00-25
03	26-50
04	51-100
05	100 +

Remarks Code

01	Satisfactory
02	Vandalized
03	Requires one-for-one replacement
04	Obsolete
05	Requires text revision
06	Location inappropriate
07	Struck by vehicle
08	Weather damage
09	Does not meet sign size standards
10	Does not meet letter size standards
11	Does not meet location standards
XX	Other

Date Replaced

Code as described under "Date Installed." Code date an existing sign is replaced with a new sign, or date the sign is dropped from inventory.

STOCKS / INVENTORY

The National Park Service "Traffic Control Sign System Guideline (NPS-52)" is very specific in detailing the responsibilities of the Regional Director and Park Superintendents. The duty to maintain signs in a safe and reasonable condition involves inspection, anticipation of defects and conformity with generally accepted standards and practices. The carrying out of these responsibilities includes the maintenance of stock materials for repairing signs, and an inventory of replacement signs particularly those required regulatory and warning signs.

Through periodic inspections and recording of these inspections on the park sign inventory, the Park manager can develop a list of those materials most often used and those signs most likely to be subject to theft and vandalism and acquire and maintain a stock accordingly.

CHAPTER 4: GENERAL FUNCTIONS AND CATEGORIES OF SIGNS

STANDARD TRAFFIC CONTROL SIGNS

All National Park Service roads - except four or more lane roads or parkways, are considered to be within the conventional road or street category referred to in the MUTCD. Standard size regulatory and warning signs as designated in the Standard Highway Signs Book should normally be used on these park roads. Parkways and four or more lane roads shall use standard sizes specified in this manual or larger, to conform with adjacent jurisdictional signs.

Signs other than those classified and specified in the MUTCD may be required to aid enforcement of Federal and local laws or regulations. These signs should be in conformance with the general specifications for lettering, shape, color, and placement as outlined in the MUTCD or a locally adopted State manual. Regulatory signs must be either enforceable under the State Vehicle Code or an order prepared under the Code of Federal Regulations, Title 36, Chapter 1, Part 4, Vehicles and Traffic Safety.

DIRECTIONAL/INFORMATIONAL GUIDE SIGNS

Lettering size for these signs is based upon roadway categories as determined by the posted speed limit of the road. These speed limits shall be determined by engineering study and traffic data. The factors to be considered are: the prevailing vehicle speeds; the roadway physical features; accident experience; and traffic characteristics and control. The area sign committee in consultation with a professional traffic engineer where appropriate, should review the design speed of all roads and the enforceability of the posted speed limits to ensure that visitor safety criteria are met.

When selecting the letter size required for guide signs, refer to the following guidelines and chart. Sizes shown are *minimum* and should not be reduced. Whenever engineering judgment warrants, the size of the letters should be increased to the next larger size. These signs include advance, exit, directional, and gore area signs.

- a. Category 1: Divided roadways and parkways having a posted speed limit of 50-55 m.p.h.
- b. Category 1A: Roads having a posted speed limit of 50-55 m.p.h.
- c. Category 2: Roads having a posted speed limit of 35-45 m.p.h.
- d. Category 3: Roads having a posted speed limit of 0-30 m.p.h.

LAYOUT CHART - ROAD SIGNS

		UC Letter A	LC Letter B	Margin Space C	Symbol Plate D	Size of Border E	Corner Radius F	Arrow Length (Minimum) G	Arrow Width H
Road Signs	Optional Category 1 50-55	12"	8"	8" min.	24"	1"	6"	18.125"	12.125"
	Categories 1, 1A 50-55	9"	6"	6" min.	18"	1"	6"	13.3125"	9.00"
	Category 2 35-45	6"	4"	4" min.	18"	.75"	4"	9"	6.125"
	Category 3 0-30	3.75"	2.50"	2.50" min.	12"	.75"	2.5"	5.625"	3.75"

Special informational signs such as stream crossings, County and State lines, mountain peaks, elevations, etc. should use 3.75" uppercase letters and 2.5" lowercase for all category roadways.

Where the sign is placed and what the sign says are both important for safety. The visitor must have time to make a decision between the sign and the decision point. The visitor's decision should be confirmed by additional signs which enable him to proceed without confusion.

ADVANCE NOTICE SIGNS

National park areas are destinations for many travelers. Cooperation with State, County, or other agencies having jurisdiction over approach roads or main highways, including Interstates, must be obtained to adequately direct visitors to their destination. Where warranted by the interest and travel objectives of the traveler, as well as by the importance of the area, an appropriate guide sign might bear a legend such as:

Valley Forge
NATIONAL HISTORIC PARK
NEXT 2 EXITS

When advance notice signs outside of a park area are requested, supplied or placed by the park, the justification of the proposed design must be in conformance with the MUTCD.

Memoranda of Agreement between State and local highway department and Park Superintendents or Regional Directors regarding cooperation in the construction, maintenance, access, and signing of roads are encouraged. Detailed signing supplements must be appended which outline the State's authority and responsibility for installation and maintenance of signs within its right-of-way. Copies of all such memoranda and agreements must appear in the park sign plan.

ENTRANCE SIGNS

The National Park Service tradition of special and unique entrance signs should be continued. Although there is much to be said in developing consistent parkwide signing, non-uniform entrance signs are an exception. The park sign committee may elect however, to follow the standard sign design as outlined in the Service manual.

Entrance signs are perhaps the most important of all informational signs when the visitor is searching for his first glimpse of the park. Advantage should be taken of this because it is often possible to find a combination of placement and construction that captures and reflects the true significance or spirit of the park.

It may be desirable to use a distinctive supporting structure or base that establishes and/or enhances the feeling that the visitor has crossed a threshold into an area providing a different experience. These bases, however distinctive, must be as hazard free as possible to the motoring public. Ideally, entrance signs are constructed to permit the replacement of the text portion of the sign without disturbance to the base structure.

The information on an entrance sign does not require Department and National Park Service designation since this information is now incorporated in the NPS emblem design. If the designation is used, it will be given in the following manner.

**United States Department of the Interior
National Park Service**

Capitalization shall be as shown above and the letters for "National Park Service" shall not be larger in size than those letters for "United States ... Interior". The letter size should be large enough to be readable from a moving vehicle (unless entrance is walk in only), but never should be higher than the height of the capital letters of the name of the area.

Entrance signs shall be restricted to containing the Park name, the arrowhead, the optional Park logo, and any cooperating agency logo. Entrance signs may also include the words "Entering" or "Welcome to".

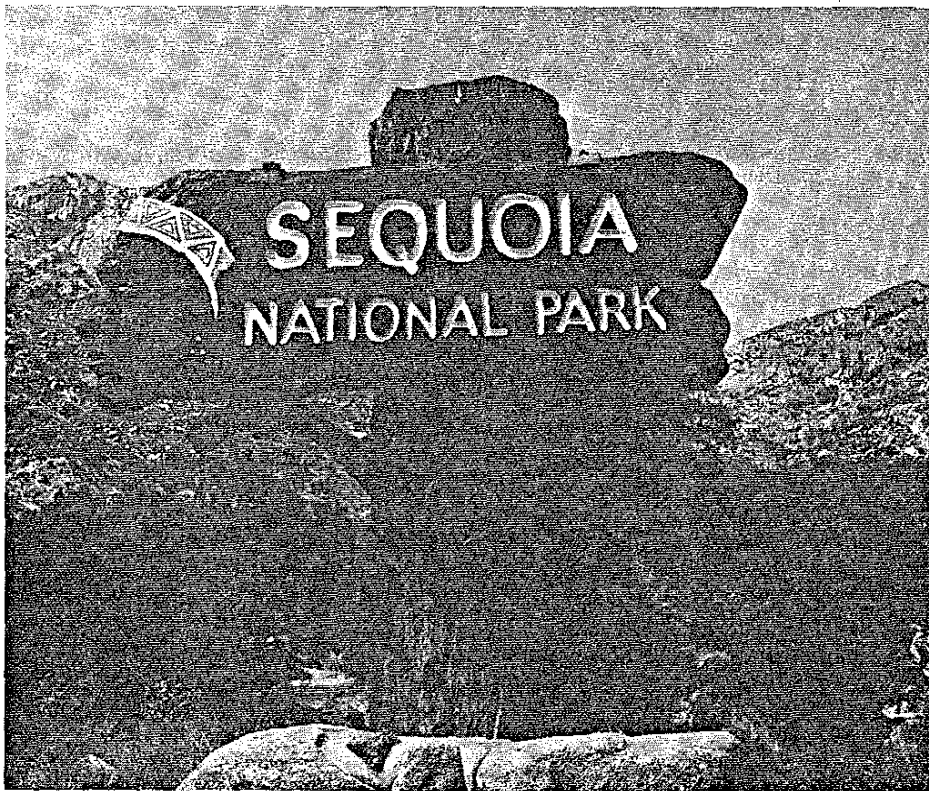

TRAVELERS INFORMATION SIGN

The purpose of these signs is to alert motorists approaching an Park of special travelers information being broadcast on AM radios. Signs would instruct motorists to turn vehicle radio to one of two AM frequencies, 530 KHz or 1610 KHz. Sign legend shall read "Travelers Information Tune Radio to 530 KHz (or 1610 KHz)". Such signs shall have reflectorized white letters and border on a brown background. Erection of signs must be coordinated with State Highway Departments. Exact location will be provided by the Chief Telecommunication Engineer after radio coverage is determined.

Selected large Parks provide roadside interpretive and other information to motorists using this same radio frequency. Until a uniform radio information symbol is developed, Parks shall use a sign with the text, "Visitors Information Tune Radio to 530 KHz (or 1610 KHz)" as needed.

NPS ROUTE MARKERS

A NPS Route Marker is available as an optional road-marking device. This marker shall be used in those Parks where it is desirable to mark park routes to facilitate visitor travel, or for other traffic considerations. If the NPS Route Marker is used it shall be the one pictured in Chapter 5 of the Sign Manual. The maximum number of digits that can be used is three.

U.S. AND STATE ROUTE MARKERS

U.S. and State Route Markers shall not be used in Parks except where the road is primarily a through, rather than park route, e.g. U.S. 101, Lake Crescent Section, in Olympic National Park. To assist visitors, a directional sign may include a U.S. or State Route number as text (see section 2D-11 of the MUTCD).

BICYCLE TRAIL SIGNING

All bicycle trail signing should conform to the extent determined possible with Part IX of the MUTCD.

SAFETY SIGNS

Whenever there is a hazard that might reasonably be expected to result in injury to Service personnel or the visiting public, signs warning of the hazard must be installed. The need for and the placement of this type of sign shall be carefully considered to ensure that persons who might be exposed to the hazard will be adequately warned in accordance with the American National Standards Institute color code (ANSI Z-535), as follows:

- a. Fire and Danger signs - red on white
- b. Hazard signs - black on orange
- c. Caution signs - black on yellow
- d. Safety and First Aid Equipment - green on white
- e. Radiation Hazard signs - black on yellow

NAVIGATIONAL AIDS

All signs displayed on waters under the jurisdiction of the National Park Service shall conform to the "Uniform State Waterway Marking System" (USWMS). Titles 33 and 46, Code of Federal Regulations are applicable on navigable waters of the United States.

Title 33 Section 403 of the Code of Federal Regulations requires that a permit be obtained from the U.S. Army Corps of Engineers (COE) prior to the installation of structures in the navigable waters of the United States. A buoy anchored to the seabed or river bed is considered a fixed structure or object thus requiring a permit.

Signs include but are not limited to:

- a. *Danger*: Orange bordered diamond symbol on white background. Words within border may include "Rock", "Dam", "Snag".
- b. *Keep Out*: Orange bordered diamond symbol with cross on white background. Words placed outside the symbol may include "Dam", "Waterfall", "Swim Area".
- c. *Restricted Area*: Orange bordered circle on white background for regulating water use activity. Words placed within border may include "5 MPH", "No Swim", "Fishing Only", etc.
- d. *Information*: Orange bordered square or rectangle on white background. Words placed within symbol may include place names, distances, arrows indicating directions, availability of supplies and facilities, etc.

AIRPORTS

All signing of runways, taxiways, etc. shall conform to the requirements of the Federal Aviation Administration (FAA). The following circulars have been published by the FAA for guidance in signing and marking.

Advisory Circular "AC 150/5340-18A",
Dated: 6/2/80,
Subject: TAXIWAY GUIDANCE SIGN SYSTEM.

Advisory Circular "AC 150/5340-1E",
Dated: 11/14/80,
Subject: MARKINGS OF PAVED AREAS ON AIRPORTS.

CIVIL DEFENSE

All Civil Defense signs under the jurisdiction of the National Park Service shall conform to the MUTCD.

PEDESTRIAN SIGNS

Pedestrian signs are generally those located along trails, walks, in or near buildings, campgrounds of other similarly developed areas. These signs are used to inform the visitor of such items as park regulations, provide direction services, and narrative and pictorial descriptions of park resources. Pedestrian guide signs used to direct the visitor to accommodations or special use facilities are to be placed in such a manner that the visitor will not become confused or lost between facilities. Pedestrian signs should always be kept to the minimum size feasible and used in locations where they will not detract from the visual scene. Symbols should be used to the greatest extent possible and should be grouped to identify facilities and/or activities within developments.

INTERPRETIVE SIGNS / WAYSIDE EXHIBITS

A general definition of an interpretive sign or wayside exhibit is a device or facility located at a significant place in the park to provide interpretation of the site or scene. These devices form an integral part of the park's coordinated interpretive program. Interpretive signs take many forms. Some are simple textual messages intended to be read from autos on the roadside. Others include plaques, markers, exhibits, panels, and demonstration displays in diverse designs appropriate to specific interpretive needs. This latter group goes beyond the scope of this Manual and is classified as an exception.

Upon installation in the area, interpretive signs and wayside exhibits become part of the Sign Survey and Inventory. Except for routine maintenance, however, the rehabilitation and replacement of interpretive signs and roadside exhibits not manufactured in accordance with this Manual remain the responsibility of the Division of Museum Planning and Design, Harpers Ferry Center.

TRAIL MARKERS/BACKCOUNTRY SIGNS

Trail Markers or Symbols: Trails designated by the National Trails System Act (P.L. 90-543) shall be marked with the uniform-symbols adopted for that trail.

Other park trails should use a uniform parkwide marking system for each trail. The approved recreation symbols can be used for this purpose by adding numbers or other designations to the text plaque. Alternately, another system consistent in design and quality with these specifications may be developed.

Backcountry Trail Signs: These signs should be small, and used sparingly on foot and horse trails in backcountry or wilderness areas. They generally should be used only at trail junctions, to mark campsites, etc. The use of routed aluminum signs has proven to be economical and more durable than any other sign in this application. Little or no maintenance is required.

NPS ARROWHEAD EMBLEM

The NPS arrowhead emblem is the official identifying symbol of the National Park Service. Its design was approved by the Department of the Interior on July 20, 1951. The emblem shall always appear in its proper form with no embellishment or variation, to ensure consistency and promote recognition. Its use conveys to visitors their presence in an area administered by the National Park Service.

The arrowhead emblem is available in either non-reflectorized routed wood, or reflective sheeting applied to aluminum or plywood substrate. When requisitioning an emblem, specifications should clearly state the type and substrate required. Reflective emblems should be used only when necessary or desirable for emphasis after dark, and/or when placed on reflective type signs.

Colors of the NPS arrowhead emblem are standardized and shall be as follows:

Background	semigloss	20233 (cocoa brown)
Trees and buffalo outline	flat	34058 (dark blue-green)
Mountain and lake	semigloss	23690 (cream)
All lettering	gloss	17875 (white)

Color numbers are those used in Federal Standard No. 595a.

3" x 5" color chips of the standard emblem colors may be procured from:

GSA Specifications Unit
Room 6039
7th & D Streets, S.W.
Washington, D.C. 20407

The routed wood official emblem is available in eight sizes:

10" x 8" x 2"	15½" x 12¼" x 2"	40" x 31 ¾" x 3"
12" x 9½" x 2"	18" x 14¼" x 2"	54" x 43" x 3"
	27" x 21½" x 2"	72" x 57¼" x 3"

Reflectorized official emblems are available in the same overall dimensions, but will be mounted on 0.080 aluminum or ¾" plywood substrate. The size of arrowhead emblem selected for a given use shall be in proportion to its setting.

The full color arrowhead emblem in one of the recommended sizes shall be incorporated on all entrance signs, either on the sign itself or the base and support structure. The emblem shall be located with appropriate consideration to layout and design of the overall sign. Materials selected for the emblem shall complement the entrance sign.

The emblem may be used in limited instances on other signs, e.g. at visitor centers, ranger stations and park boundaries on major trails. The emblem also may be used individually at carefully selected sites within parks or offices, e.g. visitor centers, park headquarters, ranger stations and other visitor contact facilities. If placed on an entrance station, the emblem shall be well separated from traffic signs. The arrowhead emblem is not intended to be used routinely on road or trail signs, or buildings.

When an emblem is mounted on an entrance sign or against a building, spacers can be used to separate the emblem from its support. This produces a heavy shadow, emphasizing the arrowhead. Spacer thickness should be in proportion to the arrowhead emblem size used.

Stencils of the official arrowhead emblem in various reduced sizes may be used in other instances where official NPS identification is appropriate, e.g., publications, selected trailheads, etc. The intent is to use the emblem sparingly and with consistency.

Use of the National Park Service arrowhead emblem for any purpose other than official National Park Service operations is strictly prohibited, except with the written permission of the Director.

NOTE

**This page reserved for
arrowhead emblems decals**

LOGOS

Many parks have devised a distinctive symbol or logo for quick identification of park facilities, interpretive trails, etc. The use of a park logo is permitted when it is integrated into a design-coordinated series of signs and/or exhibits.

CONCESSIONS

Signs within concession areas shall be of the same color and design as those for the whole Park. *Superintendents should assist concessioners in designing and placing their signs in order to achieve a uniform appearance throughout the Park.*

Traffic control signs, exterior direction, and general information signs, which are necessary for visitor guidance within the concessioners' area, shall be installed by NPS. *If the signs are for the concessioners' information only, these signs are to be installed and maintained at the expense of the concessioner.* The wording of all concessioner signs shall be approved by the Superintendent. All exterior concessioner signs are to be included in the Park Sign Plan, whether installed at NPS expense or by the concessioner. Signs inside a concessioners' building should maintain the same quality and design standards as those erected outside.

All exterior signs used in the concessioners' areas, whether installed and maintained by NPS or the concessioner, shall conform to this sign manual. The NPS will order through normal procurement procedures those signs required by the concessioner. The concessioner shall then reimburse NPS for these signs.

Outdoor signs that advertise products by brand name, or by use of emblems or symbols in the colors or designs used by manufacturers are prohibited. Concessioners' gasoline pumps may be painted in the recognizable standard colors normally used by the oil company who supplies the gasoline, and may include the oil company's name or emblem, the size of which will not extend beyond the normal pump dimensions.

NPS PROTECTION AND REGULATION SIGNS

The purpose of signs in this series (formerly 10-Forms) is to provide adequate public notices when needed, at minimum cost.

These signs are to be used only in locations where forcible language is needed to ensure that hunters, poachers, or trespassers are served notice of park boundaries or jurisdiction. *For example, these signs can be used during hunting or fire seasons;* and because of their low cost, can be replaced whenever they become unserviceable and removed when they are not needed.

Only the signs shown in this section may be ordered and displayed. Basic colors shall be *green on white for general regulatory signs, and red on white for specific prohibited activities, fire, or emergency conditions.* Special signs or variations from the text shown for NPS protection and regulation signs are not permitted.

These signs may be requisitioned directly from National Capital Region, 515 New York Avenue N.E., (Brentwood), Washington, D.C. 20002, or Central Supply, Rocky Mountain National Park, Estes Park, Colorado 80517.

DANGER

Fumigation In Progress !

Poisonous and Flammable Gas

(Ethylene dichloride - Carbon tetrachloride)

KEEP OUT !

(Sign 10-9)



AREA CLOSED

**ALL NATIONAL PARK SERVICE AREA
BEYOND THIS POINT CLOSED TO
PUBLIC USE AND TRAVEL BECAUSE
OF EMERGENCY CONDITIONS**

UNITED STATES DEPARTMENT OF THE INTERIOR

NATIONAL PARK SERVICE

(Sign 10-10)

NATIONAL PARK BOUNDARY

Prevent Wild Fire - Keep The Park Clean

IT IS UNLAWFUL TO

Hunt, trap, or possess loaded and uncased firearms or traps.

Cut, remove, or injure any tree, shrub, or foliage, or any living thing.

Camp without a permit except in designated locations.

Kindle a fire without a permit except in designated sites.

Permit dogs, cats, and other pets to run free.

A FINE OF \$500, OR IMPRISONMENT FOR 6 MONTHS, OR BOTH COULD BE THE PENALTY FOR VIOLATION OF THESE REGULATIONS.

UNITED STATES DEPARTMENT OF THE INTERIOR
NATIONAL PARK SERVICE

(Sign 10-11)

LIMITES DE PARQUE NACIONAL

Evite fuegos en los bosques
Conserve el Parque Limpio

ES ILEGAL

Cazar, trapar, o poseer armas cargadas; o trampas. Cortar, remover, o hacerle dano cualquier arbol, arbusto o follaje, o cualquier cosa con vida.

Acampar sin un permiso, excepto en sitios designados.

Prender un fuego sin debido permiso, excepto an sitios designados.

Permitir perros, gatos y otros animales que anden reelengos.

UNA MULTA DE \$500 O CARCEL POR UN PERIODO DE SEIS MESES.

O AMBAS PENAS SERAN IMPUESTAS AL QUE VIOLE ESTAS REGULACIONES

ESTADOS UNIDOS DEPARTAMENTO DEL INTERIOR
SERVICIO NACIONAL DE PARQUES

(Sign 10-12)

THIS IS A NATIONAL PARK

**Help protect this land.
All plants, animals and
other natural features
are protected by park
regulations against
removal, destruction,
and injury.**

**UNITED STATES DEPARTMENT OF THE INTERIOR
NATIONAL PARK SERVICE**

(Sign 10-13)

THIS BUILDING

**is under the protection
of the United States
Government; destruction,
injury, or theft is punish-
able by fine up to \$500
or imprisonment for 6
months, or both.**

**UNITED STATES DEPARTMENT OF THE INTERIOR
NATIONAL PARK SERVICE**

(Sign 10-14)

NOTICE

NO HUNTING OR TRAPPING

UNITED STATES DEPARTMENT OF THE INTERIOR
NATIONAL PARK SERVICE

(Sign 10-15)

FIRE TOOLS

If they are needed for
fighting fire, break
seal. Return all tools
to this box.

UNITED STATES DEPARTMENT OF THE INTERIOR
NATIONAL PARK SERVICE

(Sign 10-16)

NOTICE

ON LANDS ADMINISTERED BY THE NATIONAL PARK SERVICE, IT IS UNLAWFUL to excavate, remove, disturb, deface, or destroy any historic or prehistoric building, structure, ruin, site, or in-place exhibit, artifact or object, or to collect, appropriate, excavate, damage, disturb or destroy artifacts, pictographs, petroglyphs, objects of antiquity, fossils or scientific specimens.

VIOLATORS ARE SUBJECT TO ARREST. CONVICTION CAN CARRY CRIMINAL PENALTIES OF UP TO ONE (1) YEAR AND/OR \$10,000.

Archeological Resources Protection Act of 1979
(16 U.S.C. 470ee)

Antiquities Act of 1906
(16 U.S.C. 433)
(36 C.F.R. 2.1)
(43 C.F.R. Part 3)

UNITED STATES DEPARTMENT OF THE INTERIOR
NATIONAL PARK SERVICE

(Sign 10-17)



SS-26

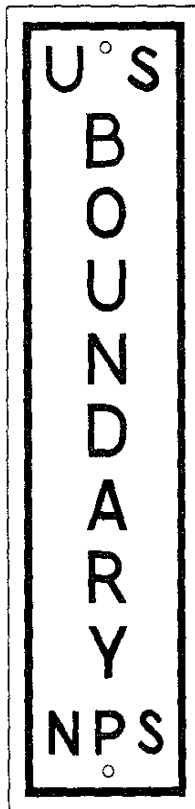

SS-27



SS-28

Prescribed Standard Protection Signs Green on White

THIS PARK BELONGS TO
ALL AMERICANS. PLEASE
HELP PROTECT IT FOR
FUTURE ENJOYMENT.

UNITED STATES DEPARTMENT OF THE INTERIOR
NATIONAL PARK SERVICE

SS-31

THE FLOWERS, ANIMALS, WOODS, AND
THE LAND BELONG TO EVERYONE; PLEASE
BE CAREFUL NOT TO DAMAGE THEM.

UNITED STATES DEPARTMENT OF THE INTERIOR
NATIONAL PARK SERVICE

SS-32

A GOOD CAMPER

CAMPS IN A PREPARED SITE
KEEPS A CLEAN CAMP
BUILDS FIRES ONLY IN FIREPLACES
EXTINGUISHES FIRES BEFORE LEAVING CAMP
CARRIES UNBURNABLE REFUSE OUT
NEVER BUILDS FIRES NEAR TREES
NEVER DRIVES NAILS IN TREES
NEVER ALLOWS DOGS OR CATS TO RUN UNLEASHED
NEVER WASHES CLOTHES OR DISHES IN STREAMS

UNITED STATES DEPARTMENT OF THE INTERIOR
NATIONAL PARK SERVICE

SS-33

PLEASE
LEAVE THE FLOWERS
FOR OTHERS TO ENJOY

SS-34

Prescribed Standard
Protection Signs
Green on White

SYMBOL SIGNS

Now used throughout the world, symbols provide a common, non-verbal language to transmit information to visitors regardless of their native language. In line with this, Federal recreational symbol signs have been developed and approved by a Federal Interagency Committee. Adherence to the Interagency Committee's adopted symbols is important to achieve and maintain uniformity with other governmental entities who also use these symbols. Symbols are intended for use whenever they can be effectively substituted for a worded message. To determine whether or not a symbol sign would be appropriate for a specific use, the following criteria should be evaluated:

1. Is the use for a facility, service or activity? Symbols should be used to establish distinctions between facilities, services and activities.
2. Is the activity, service or facility obvious? The obvious should *not* be symbolized.
3. Is the symbol repetitious of text identification that already exists? Both should not be used. Worded signs or bulletins should continue to be used to explain detailed information which symbols cannot convey.
4. Does the symbol identify the activity, service or facility to the extent that an explanatory text is not required? If the symbol will not stand by its own merit, it should not be used.

Text, prohibitive wording and arrows will not be used on the main recreation symbol but will be separate plaques added below the main symbol. Special justification and the approval of the Regional Sign Coordinator are required for the use for supplemental text plaques.

Prohibitive symbols will show a red slash from the upper left to lower right of the plaque. Prohibitive text is not required (See footnote on page 4-34).

Secondary symbols shall only be used on signs in Category 1, 1A, 2 and 3, and only when absolutely necessary.

Permissible symbol plate sizes are dependent on roadway category as shown in the following chart:

	Base Symbol	W/Secondary Symbol
★ Category 1	24" x 24"	24" x 36"
Category 1, 1A, and 2	18" x 18"	18" x 28½"
Category 3	12" x 12"	12" x 18½"
Category 4	8" x 8"	N/A
Category 5 and 5A	6" x 6"	N/A

★ Oversized, to be used on high speed roads.

Recreational symbols are to be ordered on Form 10-84C, Recreation Symbol Requisition Form.

In certain cases approved recreational symbols will not meet a special need in a park. The Superintendent working with the Regional Sign Coordinator may then develop special symbol designs to be used only for this one specific instance or until such time as a new symbol is adopted by the Federal Interagency Committee.

Symbol RS-028 "International Symbol of Access for the Handicapped Sign" shall be displayed only on those facilities intended for public use in which a person in a wheelchair can enter unassisted, conduct his business, and return to the mainstream of pedestrian traffic or a parked automobile without meeting physical impediments of design or construction. Symbol shall be white on blue at all times.

Symbol RS-024 "First Aid" shall be white on brown background and a red cross.

FEDERAL RECREATION SYMBOLS

Accommodations



Restrooms
RS-022

Restrooms for both men and women.



Lodging
RS-018
Public overnight accommodations (hotel, lodge, motel, etc.).



*** Parking**
RS-034
No Parking



Food Service
RS-019
Restaurant, cafeteria, snack shop, lunchroom, etc.



Sleeping Shelter
RS-037
Trail sleeping shelter.



Men's Restroom
RS-021



*** Campground**
RS-038
No Camping
Public campground (primary symbol), all types of camping.
Closed to camping.



Women's Restroom
RS-023

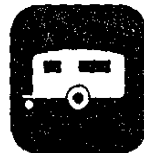

*** Trailer Sites**
RS-040
No Trailers
Campground restricted to hard sided vehicles (RV's, trailers, etc.) exclusively; sites with trailer backups.
Facility or area closed to trailers.

FEDERAL RECREATION SYMBOLS

Winter Recreation



Winter Recreation Area
RS-077

Primary symbol for winter sports recreation area.



Ski Touring
RS-046



* Ice Skating
RS-050
No Skating
Safe ice skating area.
Ice unsafe, or area closed to skating.



* Downhill Skiing
RS-047
No Downhill Skiing
Downhill ski trail
Area closed to downhill skiing.



* Ski Bobbing
RS-051
No Ski bobbing
Ski bobbing trail
An area or trail closed to ski bobbing.



Ski Jumping
RS-048
Ski jumping facility.



* Snowmobiling
RS-052
No Snowmobiles
Symbol adopted by International Snowmobile Conference to designate where snowmobiles are permitted or trails for their use.
Area or trail where snowmobiles are prohibited.



* Sledding
RS-049
No Sledding
Sledding and snow play area
Sledding and snow playing prohibited.



* Snowshoeing
RS-078
No Snowshoeing
Area where snowshoeing is permitted.
Area where snowshoeing is prohibited.

FEDERAL RECREATION SYMBOLS

Services

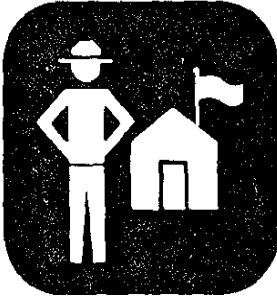

**Ranger Station
RS-015**

Ranger station or administrative office.



*** Drinking Water
RS-013**

Developed domestic water supply.



**Telephone
RS-025**

Public telephone.



**Information
RS-014**

Text "Information" required. Visitor information.



**Post Office
RS-026**



**Grocery Store
RS-020**

Groceries, food, or camp store.



**Mechanic
RS-027**

Automobile or boat repairs.



**First Aid
RS-024**

(Cross is red).
First aid station, or clinic.



**Mobility Impaired
RS-028**

Facility accessible to the mobility impaired.
(white on blue only)



Airport
RS-029

Public airport or landing strip.



Viewing Area
RS-036

Observation point from which scenic and historic areas can be seen or photographed.



Lockers
RS-030

Locked storage.



Picnic Shelter
RS-039



Bus Stop
RS-031

Bus or tour vehicle stop.

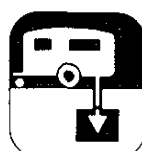

Trailer Sanitary Station
RS-041

Facility designed for dumping wastes from trailer holding tanks.



Gas Station
RS-032

Gas station or gas dock.



Trail Shelter
RS-043

Trail shelter providing some protection from the weather.



Vehicle Ferry
RS-033



*** Picnic Area**
RS-044

No Picnicking



Showers
RS-035

Shower facility (can be used with No. RS-021, 022, 023).



Kennel
RS-045

Public kennel for pets.



**Laundry
RS-085**

Area where washing and
drying facilities are available.



**Litter Receptacle
RS-086**

Receptacle or area
to deposit litter.

FEDERAL RECREATION SYMBOLS

General

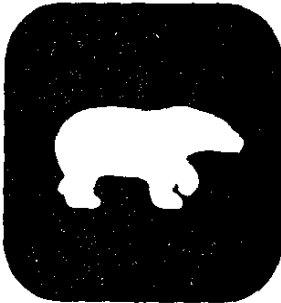

**Bear Viewing Area
RS-012**

Area where bear are habitual
and might be seen.



*** Firearms
RS-001
No Firearms**
Area where firearms
are permitted.
*Area where firearms are
prohibited. (Does not de-
scribe types of firearms.)*



**Tunnel
RS-005**

Tunnel (not a traffic sign)
for use on trails, etc.



*** Smoking
RS-002
No Smoking**
Area where smoking is per-
mitted.
Area closed to smoking.



**Lookout Tower
RS-006**

An observation, lookout, or
fire tower.



*** Automobiles
RS-003
No Vehicles**
Roadway or other facility
for automobiles.
Roadway closed to automobiles



**Lighthouse
RS-007**



*** Trucks
RS-004
No Trucks**
Roadway where trucks are
allowed, truck route.
*Roadway or other facility
closed to trucks.*



**Falling Rocks
RS-008**

Areas of falling rocks (not
a traffic sign) for use on
trails, etc.

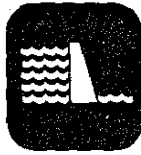

Dam
RS-009



Point of Interest
RS-080
Used to denote a scenic,
historical, cultural, etc.,
point of interest.



Deer Viewing Area
RS-011
Area where deer, elk or
other ungulates are
habitual, and might
be seen.



*** Pedestrian Crossing**
RS-016
No Crossing
Road crossing for use on
trails (not a traffic sign).



*** Pets on Leash**
RS-017
No Pets
Pets are permitted but must
be kept under physical
restrictive control.



*** Campfires**
RS-042
No Fires
Campfires permitted.
Campfires prohibited.



**** Environmental Study Area**
RS-076
Environmental Study Area,
or special environment
program area.

**** Permission to use RS-076 (Environmental Study Area)**
must be granted by, Director, National Park Service,
Washington, D.C. 20013-7127

FEDERAL RECREATION SYMBOLS

Land Recreation



Hiking Trail
RS-068
No Hiking



* **Horse Trail**
RS-064
No Horses
Horse riding trail.
Trail closed to horses or horses prohibited.



Playground
RS-069



* **Trail Bike Trail**
RS-065
No Trail Bikes
Trail open to trail bikes, scooters, or motorcycles.
Trail closed to trail bikes, scooters, or motorcycles.



Amphitheater
RS-070

Amphitheater, campfire circle, or other assembly point where programs are presented (not a visitor center).



* **Bicycle Trail**
RS-066
No Bicycles
Trail or road for bicycles.
Trail or road closed to bicycles.



Tramway
RS-071

Tramway, ski lift or similar device.



* **Recreation Vehicle Trail**
RS-067
No Off-road Vehicles
Trail or road for jeeps, 4-wheel drive, or other off-road recreation vehicles.
Trail or road closed to jeep, 4-wheel drive, or other off-road recreation vehicles.



* **Hunting**
RS-072
No Hunting - No Shooting
Area open to hunting (not to describe type of hunting permitted).
Area closed to hunting.



**Stable
RS-073**

Public horse or mule stable.



*** Rock Collecting
RS-083**

No Rock Collecting
Area where rock collecting is permitted.
Area where rock collecting is prohibited.



**Interpretive Trail
RS-074**

Interpretive trail with numbered markers or used with a guide booklet. (Oversized plates can be used for sequential numbers or to show directions).



*** Spelunking
RS-084**

No Spelunking
Area where spelunking or caving is permitted.
Area where spelunking or caving is prohibited.



**Interpretive Auto Road
RS-075**

Interpretive auto tour route with numbered markers or interpretive signs or used with guide booklet or other devices. (Oversized plates can be used for sequential numbers or to show directions).



*** Technical rock-climbing
RS-081**

No Rock-Climbing
Area where technical rock-climbing is permitted.
Area where technical rock-climbing is prohibited.



*** Climbing
RS-082**

No Climbing
Area where climbing is permitted.
Area where climbing is prohibited.

DOWNHILL SKIING SYMBOL (RS-047)

Trail marking system for three classes of ability.

**Easiest
(Green Circle)**



**More Difficult
(Blue Square)**



**Most Difficult
(Black Diamond)**



(18'' x 18'' maximum symbol size and 18'' x 6'' plaque size - Category 2)
(Arrow length - 3½'')

CROSS COUNTRY SKIING SYMBOL (RS-046)

Trail marking system
for three classes
of ability.

**Easiest
(Green Circle)**



**More Difficult
(Blue Square)**



**Most Difficult
(Black Diamond)**



(18" x 18" maximum symbol size and 18" x 6" plaque size - Category 2)
(Arrow length - 3½")

FEDERAL RECREATION SYMBOLS

Water Recreation



Marina
RS-053
Primary symbol for water-oriented recreation, boat dock, harbor, boat slips, or boat marina



Fish Hatchery
RS-010



*** Row Boating**
RS-057
No Row Boating
Area for hand-propelled boats (row boats, canoes, kayaks).
Water closed to hand-propelled boats.



*** Launching Ramp**
RS-054
No Launching
Boat launching ramp.
Boat launching prohibited.



*** Water Skiing**
RS-058
No Water Skiing
Water skiing permitted.
Water skiing prohibited.



*** Motor Boating**
RS-055
No Motor Boating
Area for motor boats or motor vessels.
Motor boats prohibited.



*** Surfing**
RS-059
No Surfing
Water or beach where surfing is permitted.
Water or beach closed to surfing.



*** Sailboating**
RS-056
No Sailboating
Area where sailboats are permitted.
Area where sailboats are prohibited.



*** Scuba Diving**
RS-060
No Scuba Diving
Scuba diving permitted.
Scuba diving prohibited.



* **Swimming**
RS-061
No Swimming
 Swimming permitted.
Swimming prohibited.



* **Wading**
RS-088
No Wading
 Area where wading is permitted.
Area where wading is prohibited.



* **Diving**
RS-062
No Diving
 Diving permitted.
Diving prohibited.



Prohibiting Red Slash



* **Fishing**
RS-063
No Fishing
 Water open to fishing (not to describe type of fishing allowed).
Water closed to fishing.

* This symbol can be used with a prohibiting red slash to prohibit this use or activity (per secondary text).



* **Canoeing**
RS-079
No Canoeing
 Area where canoeing is permitted.
Area where canoeing is prohibited.



Boat Tours
RS-087
 Interpretive boat-tour route, with numbered markers or interpretive signs, or for use with guide booklet or other devices. (Oversized plates may be used for sequential numbering or to show direction.)

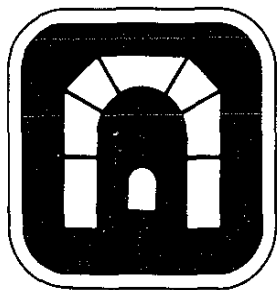

VEHICULAR SYMBOL PLATE

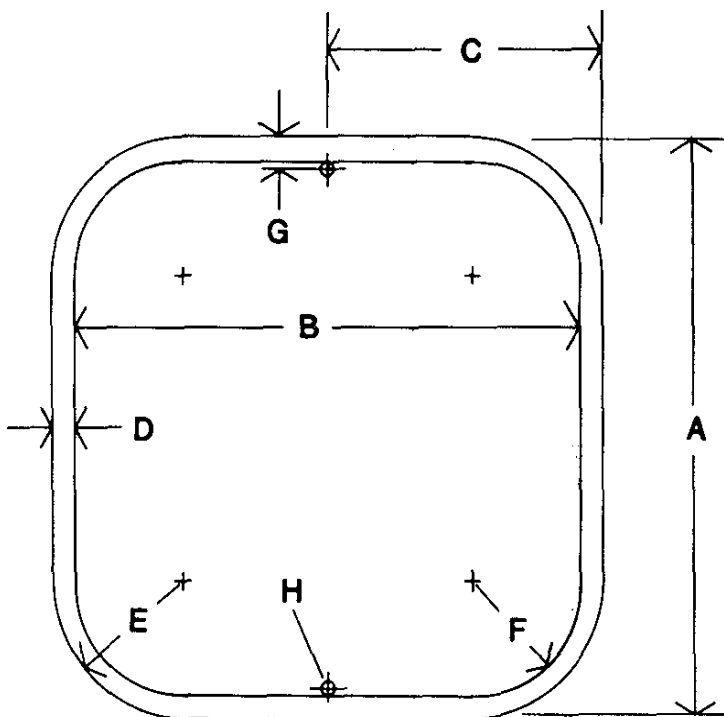

Vehicular symbol plate layout dimensioning

Category	A	B	C	D	E	F	G	H
1	24"	22½"	12"	¾"	4¾"	4"	1½"	3/8"
1A, 2	18"	16½"	9"	¾"	4¼"	3½"	1½"	3/8"
3	12"	11"	6"	½"	2¾"	2¼"	1"	3/8"

Note: E and F values are radii. H values are diameters.

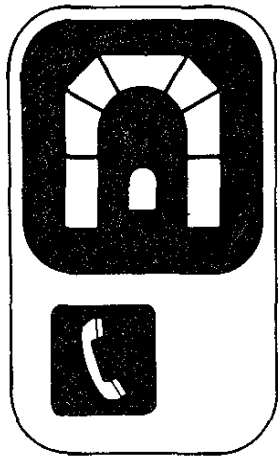

VEHICULAR
OVERSIZED SYMBOL PLATE
WITH SECONDARY SYMBOL

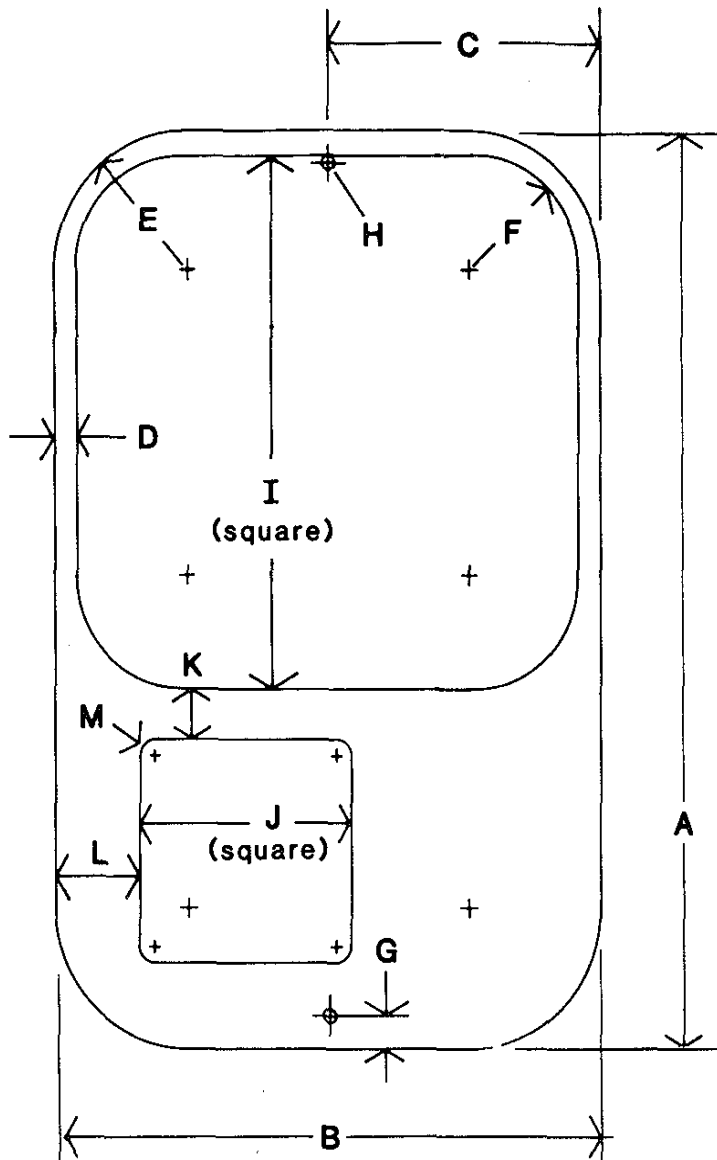

Vehicular oversized symbol plate with secondary symbol layout dimensioning

Category	A	B	C	D	E	F	G	H	I	J	K	L	M
1	36"	24"	12"	¾"	4¼"	4"	1½"	3/8"	22½"	11"	1"	2½"	2¼"
1A, 2	28½"	18"	9"	¾"	4¼"	3½"	1½"	3/8"	16½"	7"	1½"	2¾"	½"
3"	18½"	12"	6"	½"	2¾"	2¼"	1"	3/8"	11"	5"	½"	1½"	½"

Note: E, F and M values are radii. H values are diameters.



PEDESTRIAN SYMBOL PLATE

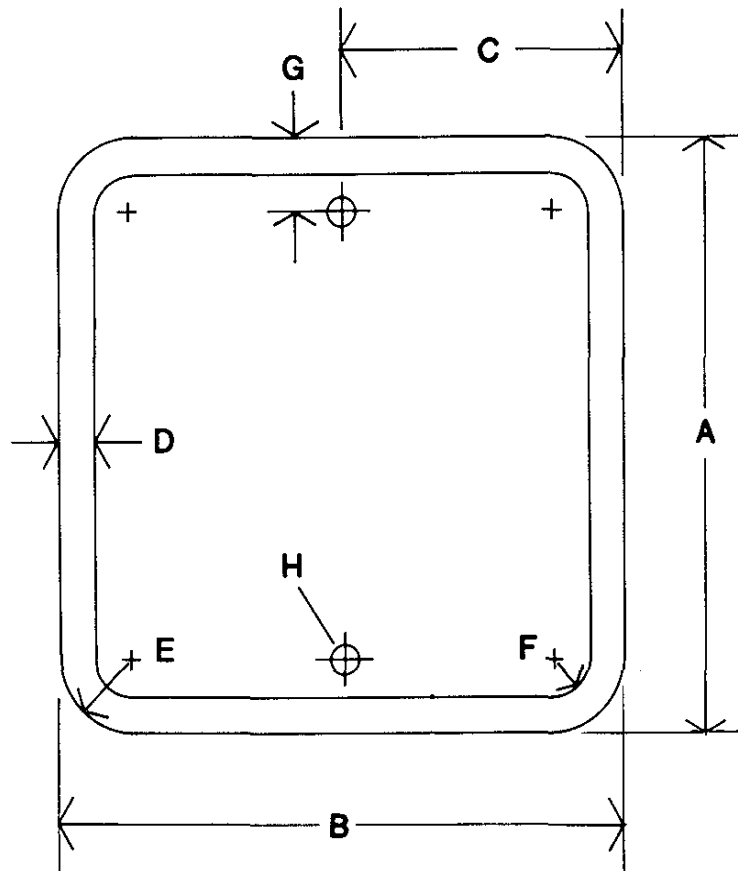

Pedestrian symbol plate layout dimensioning

Category	A	B	C	D	E	F	G	H
4	8"	7"	4"	½"	1"	½"	1"	¾"
5, 5A	6"	5"	3"	½"	1"	½"	1"	¾"

Note: E and F values are radii. H values are diameters.

HORIZONTAL/
VERTICAL
ARROW
DIMENSIONS

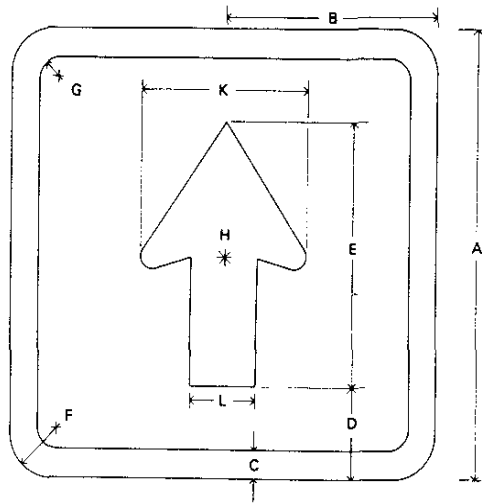

SYMBOL PLATE ARROW

USAGE CATEGORY	A	B	C	D	E	F	G	H*	J	K	L
1	12"	6"	1/2"	1 1/2"	9"	2 3/4"	2 1/4"	ROTATION POINT	3 5/8"	6 1/8"	4 1/2"
1A, 2	12"	6"	1/2"	1 1/2"	9"	2 3/4"	2 1/4"		3 5/8"	6 1/8"	4 1/2"
3	8"	4"	1/2"	1 1/8"	5 5/8"	1"	1/2"		2"	3 3/4"	2 5/8"
4	4"	2"	1/4"	7/8"	2 1/4"	3/8"	1/8"		1 1/2"	1 1/2"	27/32"
5	4"	2"	1/4"	7/8"	2 1/4"	3/8"	1/8"		1 1/2"	1 1/2"	27/32"

SEE ARROW SPECIFICATIONS FOR ARROW SIZE

* H = TRUE CENTER OF PLAQUE ARROW IS CENTERED ON THIS POINT FOR VERTICAL OR DIAGONAL PLACEMENT

DIAGONAL
ARROW
DIMENSIONS

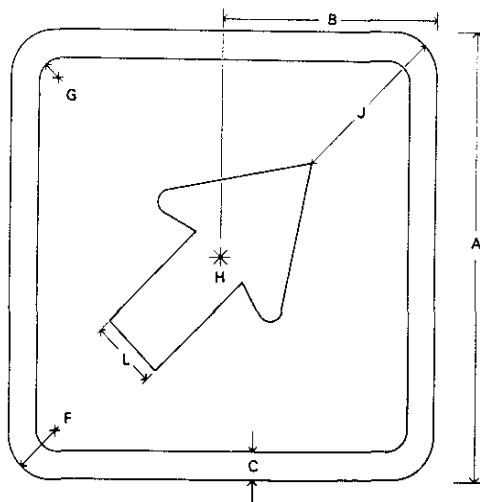

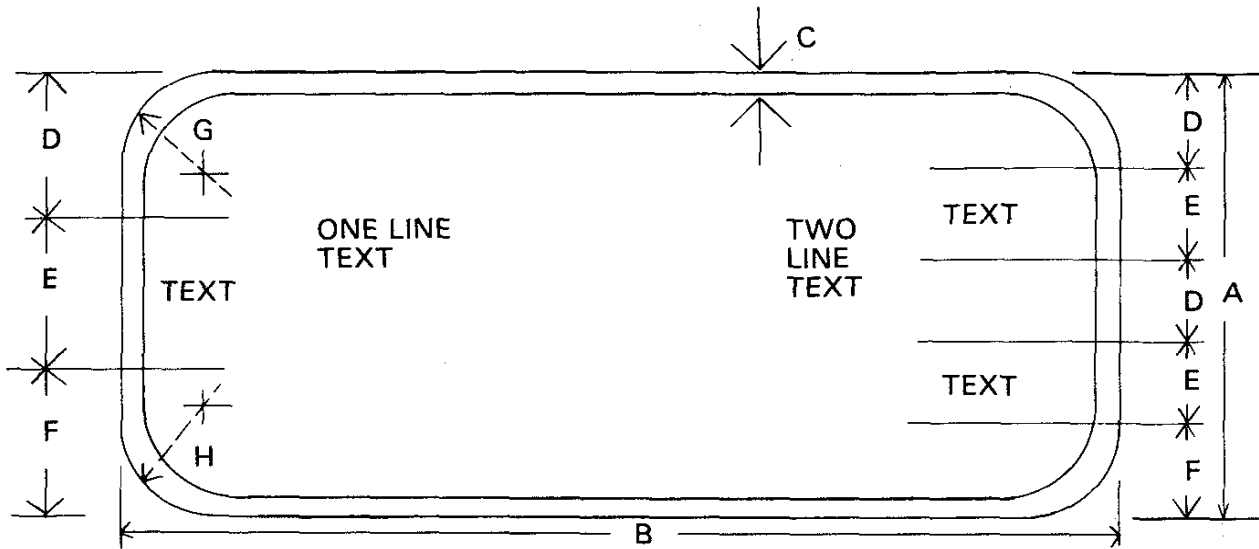

TEXT PLAQUE

USE CATEGORY		A	B	C	D	E	F	G	H
1	ONE LINE TEXT	8"	24"	½"	1¾"	3.75" UC 2.50" LC	2½"	2"	1½"
	TWO LINE TEXT	8"	24"	½"	1"	2.25" UC 1.50" LC	1½"	2"	1½"
1A	ONE LINE TEXT	6"	18"	½"	1½"	2.25" UC 1.50" LC	2¼"	1½"	1.0"
	TWO LINE TEXT	6"	18"	½"	7/8"	1" UC 1.50" LC	1¼"	1½"	1.0"
2	ONE LINE TEXT	6"	18"	½"	1½"	2.25" UC 1.50" LC	2¼"	1½"	1.0"
	TWO LINE TEXT	6"	18"	½"	7/8"	1.5" UC 1" LC	1¼"	1½"	1.0"
3	ONE LINE TEXT	4"	12"	3/8"	1"	1.5" UC 1" LC	1½"	1"	13/16"
	TWO LINE TEXT	4"	12"	3/8"	9/8"	1" UC .67" LC	7/8"	1"	13/16"
4	ONE LINE TEXT	3"	8"	1/8"	9/16"	1.5" UC 1" LC	15/16"	3/4"	5/8"
	TWO LINE TEXT	3"	8"	1/8"	.55"	.67" UC ONLY	.56"	3/4"	5/8"
5A	ONE LINE TEXT	3"	6"	1/8"	13/16"	1" UC .67" LC	13/16"	9/16"	7/16"
	TWO LINE TEXT	3"	6"	1/8"	.55"	.67" UC ONLY	.56"	9/16"	7/16"

CHAPTER 5: RULES FOR FORMULATING SIGN SIZE AND TEXT

GENERAL

The detailed guidelines on the following pages are the rules that govern the design of text, layout, and overall size for National Park Service signs. The critical determining factor of letter size is the maximum vehicle speed allowed and/or reading time. Minimum letter sizes can be determined for all sign types based on the charts and rules on the following pages.

Where sign size is not extremely critical, it is suggested that the final design be left up to the discretion of the manufacturer. The Park need only determine the message, general layout and size of letters required. In the case of signs ordered from UNICOR, the park shall fill out the appropriate order form and UNICOR will compute the necessary dimensions. If sign size is critical, the detailed steps outlined in this chapter should be followed.

SPECIFIC RULES

The following rules apply to Destination, Direction, and Information signs in Categories 1-5A and OTHER unless otherwise noted.

Position of Arrows

Arrows can be used to point in eight different directions: straight up or down, straight left or right (90 °), oblique right up or down (45 °), or oblique left up or down (45 °).

Arrows are to be positioned to the left of the message when pointing straight up, straight down, straight left, or oblique left up or down. They are to be positioned to the right of the message when pointing straight right or oblique right up or down.

On roads where site conditions dictate a narrow sign, and an arrow positioned to the left or right of the message would result in an overly wide sign, the arrow may be centered below the message. This is not applicable to directional signs with more than one arrow.

On trail signs with numerous destinations, for greater clarity a single arrow may be placed above a group of destinations with common directions. Arrows which are so placed shall take a flush left position for any arrow direction.

Spacing Guide (NPS Modified Clarendon, Categories 1-5A ONLY)

All margins are measured from outside edges of sign panel.

Minimum Horizontal Spaces: Between right or left edge of sign and message, arrow or symbol - one lowercase letter height (see layout chart dimension C).

Between words - factor 16 (Manual Factor Table).

Horizontal spacing between symbol and word, symbol and arrow, and between symbols - factor 16.

Each row of symbols to be centered on the sign.

Between word and arrow - factor 16.

Between number and an abbreviated term, e.g. 22 mi - factor 14 (Manual Factor Table).

Minimum Vertical Spaces: Between top edge of sign and top of an uppercase letter in first line - one lowercase letter height (see layout chart dimension C).

Between lines of legend - one uppercase letter height (see layout chart dimension A).

Between lines in name phrase - one lowercase letter height.

Between bottom of legend and bottom edge of sign - one lowercase letter height (see layout chart dimension C).

Vertical spacing between legend and symbol - one lowercase letter height (see layout chart dimension B).

Vertical spacing between top or bottom edge of sign and symbol - one lowercase letter height (see layout chart dimension C).

NOTE: For minimum horizontal and vertical spacing on Category OTHER signs, refer to layout Chart.

Rules for Capitalization (NPS Modified Clarendon, Categories 1-5A only).

Destinations are always spelled in upper and lowercase letters.

Directions are spelled in uppercase letter unless direction is a part of the destination. If a direction expression is a part of a destination, it will be spelled in uppercase and lowercase letters.

NOTE: All letters on Category OTHER signs are uppercase only.

Punctuation (NPS Modified Clarendon, Categories 1-5A only)

Space between period, comma, etc., and following word - factor 16.

Space between period and following capital letter in an abbreviation, e.g., U.S. - factor 14.

NOTE: Spacing of punctuation on Category OTHER signs to be optical.

Symbols

Symbol plate, arrow plate, and text plaque sizes are shown in Chapter 4.

Fractions

Fractions shall be used only on advanced notice signs on categories 1-3 roads. Advance notice signs with fractions shall be limited to " $\frac{1}{4}$ " or " $\frac{1}{2}$ " exclusively, e.g. "Turkey Run LEFT $\frac{1}{4}$ MILE". All other destination or advance notice signs with distances shall use mileage in decimals or feet, e.g. "1.3 mi" or "600 ft".

Layout and spacing of fractions shall be as follows:

Horizontal space between text and left edge of numerator - factor 16.

Horizontal space between right edge of denominator and text - factor 14.

Horizontal space between numerator (" $1''$ ") and denominator (" $2''$ " or " $4''$ ") - factor 16.

Horizontal space between numerator and left edge of diagonal slash - factor 2 for " $\frac{1}{4}$ " only. Numerator and left edge of diagonal slash line up or " $\frac{1}{2}$ ".

Thickness of diagonal slash between numerator and denominator of fraction - $\frac{1}{8}$ uppercase letter height, A (of adjoining text). Diagonal slash shall be inclined at 60° angle from line of text.

Total height of fraction - one and one-half uppercase letter height, $1\frac{1}{2}A$ (of adjoining text). Fraction is to be centered vertically on text to right and left of the fraction.

Vertical space between first line of text (destination) and second line (direction including fraction) - one uppercase letter height, A (letter size of destination), measured from text, not top of numerator.

Minimum vertical space between direction including fraction and bottom edge of sign - one lowercase letter height, B (letter size of destination), measured from text, not bottom of denominator.

RIGHT 1/4 MILE

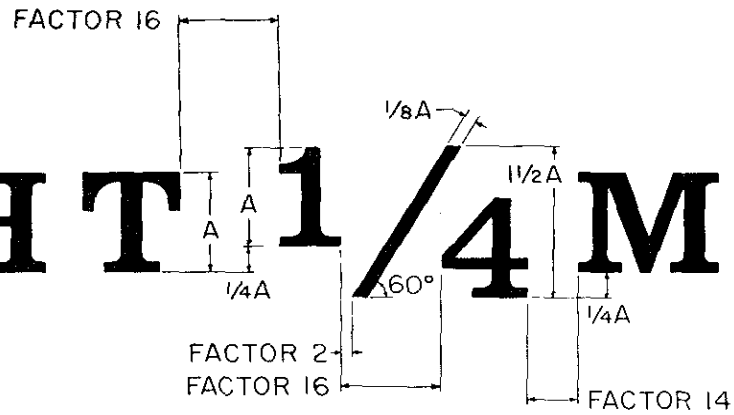

LEFT 1/2 MILE

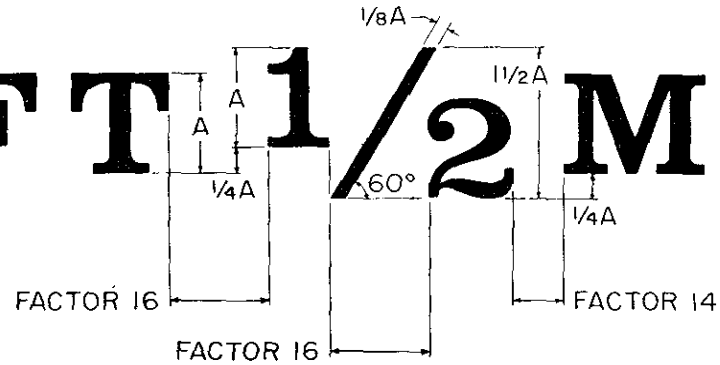

ROAD SIGNS (CATEGORIES 1, 1A, 2 and 3)

Formulating the Message

Road signs are designed for automobile traffic. Under normal driving conditions there is little time between being close enough to read the sign and passing the sign. Consequently, messages must be short. They should be confined to the essential; for example, destination and direction.

Message Rules: (Destination, Direction, and Information Signs)

1. Maximum of eight (8) words per sign.
2. Maximum of four (4) words per message, except where proper names are used (Examples: "Minute Man National Historical Park," and informational signs as "Wilderness Permits Required Pine Ridge.")
3. For signs with more than one message the following applies:
 - a. Maximum of three (3) worded messages per sign
 - b. Maximum of four (4) words per message
 - c. Total words not to exceed eight (8) words
4. If more than eight (8) words are contained in three (3) messages, the third message will be placed on a separate sign.
5. For signs combining worded and symbol messages the following applies:
 - a. Maximum of three (3) symbol plates per sign, each symbol being a separate message.
 - b. Maximum of one worded message per sign (Note: Although this worded message would normally be on one (1) line, it may be on two (2), or rarely three (3), lines if sign layout and unusual siting conditions so require. (See example below.)
 - c. Total of four (4) messages maximum.
6. To keep messages short, certain commonly recognized abbreviations may be used, e.g., "Mt." for "Mount," "Pt." for "Point," "St." for "Street." (Do not abbreviate historic proper names, e.g., "Washington" to "Wash.," "Arlington Cemetery" to "Arl. Cem." Use discretion and tact to avoid antagonizing local groups.)

Determination of Letter Size (Destination, Direction and Information Signs)

The letter size for signs to be used in a given location is determined by the maximum vehicle speed that is allowed at this point on the road system. When selecting the letter size required for road signs, refer to the following guidelines for each specific category.

Category 1: Divided roadways-Speed 50-55 m.p.h.

Major divided roadways and parkways having a moderate to high volume of traffic, such as the Baltimore-Washington Parkway and Suitland Parkway. Minimum size alphabet on guide signs (advance, exit direction and gore signs), uppercase height 9"; lowercase height 6"; arrow length 13⁵/₁₆" and arrow width 9". Symbol size 18" x 18".

Whenever engineering judgment warrants, the size of letter shall be increased to the next larger, uppercase height 12"; lowercase height 8"; arrow length 18⁵/₈" and arrow width 12¹/₈". Symbol size 24" x 24".

Category 1A: Roads - Speed 50-55 m.p.h.

Destination, Direction, and Information signs uppercase height 9"; lowercase height 6"; arrow length 13⁵/₁₆" and arrow width 9". Symbol size 18" x 18".

Category 2: Roads-Speed 35-45 m.p.h.

Destination, Direction, and Information signs, uppercase height 6"; lowercase height 4"; arrow length 9" and arrow width 6¹/₈". Symbol size 18" x 18".

Category 3: Roads-Up to 30 m.p.h.

Destination, Direction, and Information signs, uppercase height 3.75"; lowercase height 2.5"; arrow length 5⁵/₈" and arrow width 3.75". Symbol size 12" x 12".

Special Informational Signs

These signs label stream crossings, county and state lines, mountain peaks, elevations, etc. Letter size shall be 3.75" uppercase height, and 2.5" lowercase height, for categories 1-3.

NOTE: All guide signs Categories 1, 1A, 2 and 3 shall be manufactured using die-cut NPS Modified Clarendon letters.

Determination of Size of Message

The Tables of Character Widths, Spacing Charts and Manual Factor Table provide the means for measuring widths of every letter, numeral and punctuation mark in inches; determining the appropriate spacing factors between letters and words; and converting the spacing factors to inches. The values pertaining to a given message are taken from the tables together: the Character Width and Spacing Factor Values, when totalled, provide the length of a legend in inches.

Determination of Size of Sign

After the size of the message is determined, the minimum vertical and horizontal margins, and, in case of multiline messages, line spacing are added. Arrow and symbol spacings are also added, as necessary. Refer to the layout chart below, and examples at the end of this chapter.

LAYOUT CHART - ROAD SIGNS

		UC Letter A	LC Letter B	Margin Space C	Symbol Plate D	Size of Border E	Corner Radius F	Arrow Length (Minimum) G	Arrow Width H
Road Signs	Optional Category 1 50-55	12"	8"	8" min.	24"	1"	6"	18.125"	12.125"
	Categories 1, 1A 50-55	9"	6"	6" min.	18"	1"	6"	13.3125"	9.00"
	Category 2 35-45	6"	4"	4" min.	18"	.75"	4"	9"	6.125"
	Category 3 0-30	3.75"	2.50"	2.50" min.	12"	.75"	2.5"	5.625"	3.75"

Example

The following step-by-step instructions will illustrate the procedure. Sign to have text "Road", and be installed on a Category 2 road. Letter size thus will be 6" uppercase and 4" lowercase.

First Step: Determine the width of the required characters by using the Table of Character Widths on pages 5-14 & 5-15. In our example, the width of the "R" is 6.07 inches.

Second Step: Determine appropriate spacing by (1) selecting the spacing factors from the Spacing Charts on pages 5-16 through 5-27 and (2) determining the Space Factor Value from the Manual Factor Table. In the example, the spacing factor between letters "R" and "o" is 7, and its value is 1.612 inches.

Third Step: Determine legend length by adding the totals of letter widths and Space Factor Values. In our example the total of letter widths, 20.31", plus Space Factor Values, 4.841", equal legend length of 25.151 inches.

Example: Legend "Road"

Letter	R	o	a	d	
Letter Width (inches)	6.07"	+ 4.75"	+ 4.72"	+ 4.77"	= 20.31"
Space Factor	7	8	6		
Space Factor Value	1.612"	+ 1.761"	+ 1.468"		= 4.841"
Legend length (total)					25.151"

Fourth Step: Determine minimum sign size by adding the appropriate margins to legend length and height. One lowercase letter height, in our example 4", is the required minimum margin space at each end, and at top and bottom of sign. Minimum sign width is thus 33.151" (4" + 25.151" + 4"), and minimum sign height is 14" (4" + 6" + 4").

Fifth Step:

Signs are to be rounded off to the nearest 6'' horizontal and 2'' vertical increment. Therefore in this example at 33.151'' total width would be centered on a 36'' sign. The 6'' increments for horizontal measurements and 2'' increments for vertical measurements should be maintained where possible.

Example Layout: (Category 2)

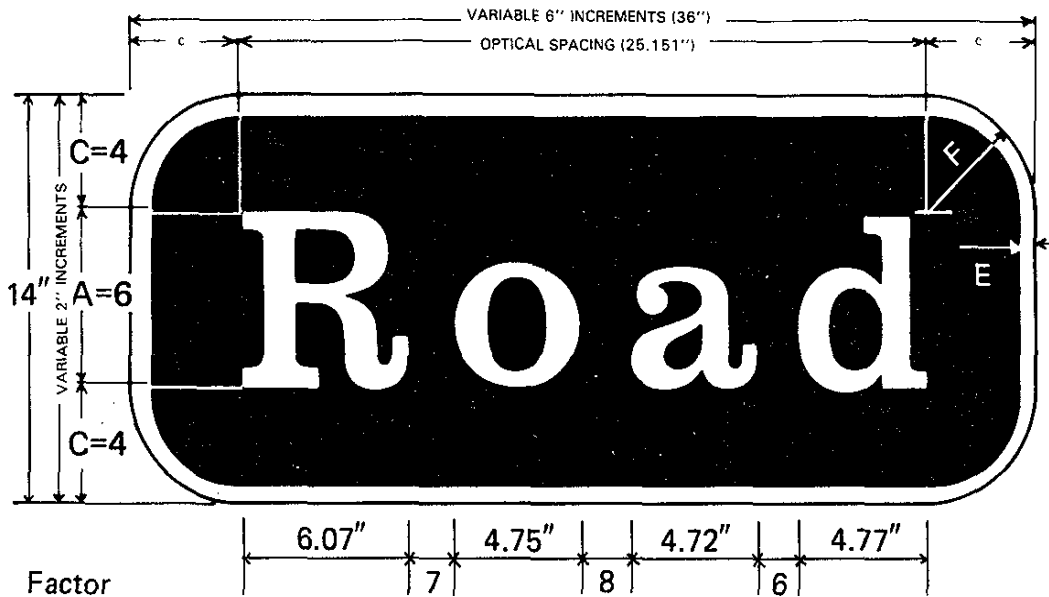

Even though the above is a simple example, the more complex ones follow the same pattern. It is recommended that a few layouts be drawn up for practice, because like every tool, this guide has to be worked with in order to be mastered.

PEDESTRIAN SIGNS (Categories 4, 5, 5A and OTHER)

These signs are used where pedestrian traffic is controlled through the use of sidewalks, trails, paths, etc. Because adequate time to read pedestrian signs is normally available, messages may be considerably more detailed than on road signs. Pedestrian signs may include directions, distances, instructions, listing, name plates, plaques, markers, object identification and descriptive texts.

Message Rules

Pedestrian Signs should be simple and concise. Text should be clear and wherever possible written in a positive, rather than negative sense.

Determination of Letter Size

Letter size for pedestrian signs is determined by location, volume of visitors using the area, and distance at which message is to be viewed.

Category 4: Uppercase height 2.25", lowercase height 1.5"; arrow length 3.5" and arrow width 2³/₈". Symbol size 8" x 8". As a general rule this category letter height can be seen at 75 to 100 feet.

Category 5: Uppercase height 1.5", lowercase height 1"; arrow length 2.25" and arrow width 1.5". Symbol size 6" x 6". As a general rule this category letter height can be seen at 50 to 75 feet.

Category 5A: Uppercase height 1", lowercase height 0.67"; arrow length 1.5" and arrow width 1¹/₂". Symbol size 4" x 4". As a general rule this category letter height can be seen at 0 to 50 feet.

NOTE: All pedestrian signs Categories 4, 5 and 5A shall be manufactured with NPS Modified Clarendon alphabet only.

Category OTHER: Letters are uppercase only. Sizes available are:

1" Arrow length	1.5";	Arrow width	1 ¹ / ₂ ";	Symbol size	4" x 4".
³ / ₄ " Arrow length	1 ¹ / ₈ ";	Arrow width	0.75";	Symbol size	3" x 3".
¹ / ₂ " Arrow length	0.75";	Arrow width	0.50";	Symbol size	2" x 2".

NOTE: All pedestrian signs Category OTHER shall be manufactured with Engineering Standard alphabet only.

All pedestrian signs Categories 4 and 5 can be manufactured using NPS Modified Clarendon die-cut or routed letters. Category 5A signs can be manufactured only with routed NPS Modified Clarendon letters. All pedestrian signs Category OTHER are available only with routed Engineering Standard letters. (See Pedestrian Sign Requisition, Form 10-84B.)

The minimum size NPS Modified Clarendon letters routed in wood are as follows:

1.5" uppercase, 1" lowercase (Category 5) - when routed in cedar, pine, fir, oak, hemlock, walnut, etc.

1" uppercase, .67" lowercase (Category 5A) - when routed in high density overlay plywood (see Chapter 6 for specification).

Determination of Size of Message

The procedure for pedestrian signs using NPS Modified Clarendon letters shall be as specified for Road Signs.

Spacing for all Engineering Standard routed letters shall be optical. Tables of character width and spacing factors have not been developed to date. Consequently, to determine size of message, test must be laid out and measured manually.

Determination of Size of Sign

Minimum vertical and horizontal margins, and in case of multiline messages, line spacings, are added to size of message. Arrow and symbol spacings are also added as necessary. Refer to layout charts on the following page, and examples at the end of this chapter.

Layout Chart - Pedestrian Signs (NPS Modified Clarendon letters)

		UC Letter A	LC Letter B	Margin Space C	Symbol Plate D	Size of Border E	Corner Radius F	Arrow Length (Minimum) G	Arrow Width H
Pedestrian and Trail Signs	Category 4	2.25 "	1.5 "	1.5 " min.	8 "	.50 "	1.5 "	3.5 "	2.375 "
	Category 5	1.5 "	1.0 "	1 " min.	6 "	.50 "	1.5 "	2.25 "	1.50 "
	Category 5A	1 "	0.67 "	1 " min.	6 "	.50 "	1.5 "	2.25 "	1.50 "

Layout Chart - Pedestrian Signs
Engineering Standard Letters

Pedestrian/Trail Signs Category OTHER	UC Letter Size a	Margin Space (minimum) b	Between lines of text; arrow above destination c	Between trail name and first arrow (vert.); destination and next arrow (vert.); destination and distance (horiz.) d	Between words (horiz.) e	Corner Radius f	Arrow Length (Minimum) g	Arrow Width h	Symbol Plate i
	1.0 "	1.5 "	1.0 "	1.5 "	1.0 "	.25 "	1.5 "	1-1/32 "	4 " x 4 "
	0.75 "	1.25 "	0.75 "	1.25 "	0.75 "	.25 "	1-1/8 "	0.75 "	3 " x 3 "
	0.50 "	0.75 "	0.50 "	0.75 "	0.50 "	.25 "	0.75 "	0.50 "	2 " x 2 "

Alternate Sizing

This example of alternate sign layouts combining symbols, a directional arrow and a single text message shows coping with varying site conditions, that may require minimum sign size. Signs are drawn to same scale. Dimensions shown apply to these signs on a category 2 road (35-45 mph: 6" uppercase and 4" lowercase letters, 18" symbols, and 6¹/₈" wide arrow. Arrow length shown is greater than standard 9" for visual balance).

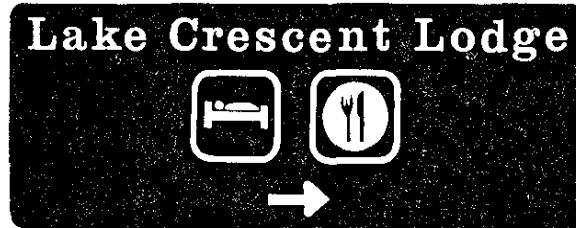

A) 10' x 3'10" (38.33 sq. ft.)

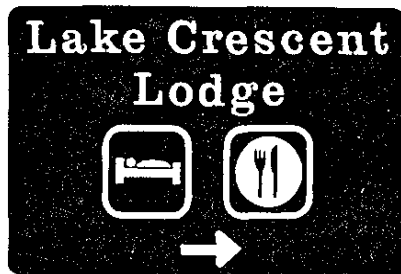

B) 7' x 4'8" (32.67 sq. ft.)

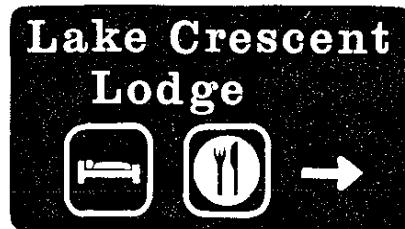

C) 7' x 3'10" (26.83 sq. ft.)

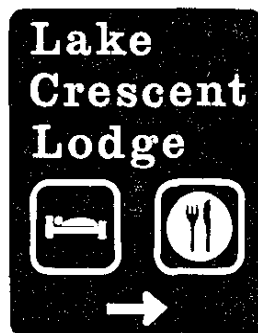

D) 4'6" x 5'6" (24.75 sq. ft.)

FINAL LAYOUT

Regional Offices are responsible for reviewing and approving the final design and layout of signs. The Regional Sign Coordinator will provide technical assistance to parks in the preparation of preliminary sign layouts. Chapter 6 contains information on ordering signs. The Regional Office is responsible for ensuring that designs are in conformance with these Specifications. In general, the decisions of sign placement, content, letter size, and so forth, will be made during preliminary planning by the area. Regional Offices will review and recommend adjustments in placement, text, symbols, size, and so forth, to increase their effectiveness.

OTHER METHODS OF DETERMINING SIGN SIZE

Computer

Exact width of individual lines of legends may be determined using a computer. The computer can be programmed with the different letter sizes and spacings. The operator needs only to know the letter height required and the legend desired. Different arrangements of Legend layout can be studied in this manner very easily. Software developed for this purpose has been made available to Regional Sign Coordinators.

Dictionary

The National Capital Region has developed a dictionary of all words that have been used in the Region. All words in the dictionary are shown with their size as determined using 1" uppercase/.67" lowercase letters. The user need only multiply this dimension by the required letter size to determine the exact length of the desired word. Spacing between words and margins are determined in the normal process. As new words are used they are added to the listings.

Quick Method for Estimating Informational Sign Messages

When an exact message length is to be determined, sign coordinators must refer to character width tables, spacing charts and the manual factor table in Appendix B of this sign manual. Many times, however, e.g. when developing alternate sign layouts, estimating sign costs, etc., a close approximation of message length will suffice.

The following quick method is based on a study of relative frequency of letters in common text, relative frequency of letters as first letters of text and an analysis of NPS Modified Clarendon spacing factors. This method generally is accurate to within $\pm 5\%$ of the exact value for words with first letter only capitalized. Do not use this method when sizing messages consisting of all caps.

★ multiply every letter (upper & lower case)	× 5.8"
★ add for every lower case g and w	+ 1"
★ add for every upper or lower case M or m	+ 2"
★ add for every upper case W	+ 4"
★ subtract for every lower case i, j, l or t: upper case J; and/or numeral 1	- 1"
★ subtract for every upper case I	- 3"
★ add for every space between words, when sizing a multiple word message only	+ 5.5"
★ deduct when message consists of lower case letters only (each word)	- 1.5"

The sum total provides the value in inches of a category 2 (6" upper case/4" lower case letter size) message.

To convert message length to other categories, the value must be multiplied by the appropriate factor listed below:

★ category 1 or 1A	(12" UC/8" LC)	× 2
★ category 1 or 1A	(9" UC/6" LC)	× 1.5
★ category 3	(3¾" UC/2½" LC)	× 0.625
★ category 4	(2¼" UC/1½" LC)	× 0.375
★ category 5	(1½" UC/1" LC)	× 0.25
★ category 5A	(1" UC/¾" LC)	× 0.167

MANUAL FACTOR TABLE
NPS Modified Clarendon — Uppercase/Lowercase Letter Heights
PEDESTRIAN SIGNS **ROAD SIGNS**

	Category 5A *1" U/C — .67" L/C	Category 5 1.50" U/C — 1" L/C	Category 4 2.25" U/C — 1.50" L/C	Category 3 (0-30) 3.75" U/C — 2.50" L/C	Category 2 (35-45) 6" U/C — 4" L/C	Categories 1,1A (50-55) 9" U/C — 6" L/C	Optional Categories 1,1A* (50-55) 12" U/C — 8" L/C
16	.914	1.370	2.056	3.426	5.482	8.223	10.964
15	.730	1.095	1.640	2.737	4.380	6.570	8.760
14	.459	.689	1.034	1.723	2.757	4.135	5.514
13	.416	.625	.937	1.562	2.500	3.750	5.000
12	.384	.576	.865	1.441	2.307	3.460	4.614
11	.365	.548	.822	1.370	2.193	3.289	4.386
10	.350	.525	.787	1.312	2.100	3.150	4.200
9	.318	.477	.716	1.194	1.911	2.866	3.822
8	.293	.440	.660	1.100	1.761	2.641	3.522
7	.268	.403	.604	1.007	1.612	2.418	3.224
6	.244	.367	.550	.917	1.468	2.202	2.936
5	.220	.330	.496	.826	1.323	1.984	2.646
4	.187	.281	.421	.703	1.125	1.687	2.250
3	.138	.208	.312	.520	.833	1.249	1.666
2	.106	.159	.238	.398	.637	.955	1.274
1	.048	.073	.109	.183	.293	.439	.586
0	.000	.000	.000	.000	.000	.000	.000

**Not available in die-cut letter fonts
 **To be used whenever engineering judgment warrants.

**CHARACTER WIDTH TABLE (NPS MODIFIED CLARENDON)
UPPER CASE & NUMERALS**

	*1"	1.50"	2.25"	3.75"	6"	9"	12"	
	U/C	U/C	U/C	U/C	U/C	U/C	U/C	
A	1.11	1.66	2.49	4.16	6.65	9.97	13.30	
B	.95	1.42	2.13	3.55	5.68	8.52	11.36	
C	.90	1.34	2.01	3.35	5.37	8.05	10.74	
D	1.02	1.52	2.28	3.80	6.09	9.13	12.18	
E	.95	1.42	2.14	3.56	5.70	8.55	11.40	
F	.89	1.34	2.00	3.34	5.35	8.02	10.70	
G	1.05	1.57	2.35	3.92	6.27	9.40	12.54	
H	1.08	1.62	2.42	4.04	6.47	9.70	12.94	
I	.47	.71	1.06	1.77	2.83	4.24	5.66	
J	.76	1.14	1.70	2.84	4.55	6.82	9.10	
K	1.07	1.61	2.41	4.03	6.45	9.67	12.90	
L	.89	1.33	2.12	3.32	5.32	8.50	10.64	
M	1.30	1.95	2.92	4.87	7.80	11.70	15.60	
N	1.08	1.62	2.42	4.04	6.47	9.70	12.94	
O	1.02	1.53	2.30	3.83	6.13	9.19	12.26	
P	.89	1.33	2.00	3.33	5.33	7.99	10.66	
Q	1.11	1.67	2.50	4.16	6.67	10.00	13.34	
R	1.01	1.52	2.27	3.79	6.07	9.10	12.14	
S	.86	1.28	1.92	3.21	5.13	7.69	10.26	
T	.92	1.37	2.06	3.44	5.50	8.25	11.00	
U	1.02	1.52	2.29	3.81	6.10	9.15	12.20	
V	1.05	1.57	2.36	3.93	6.29	9.43	12.58	
W	1.59	2.38	3.56	5.94	9.51	14.26	19.02	
X	1.11	1.66	2.48	4.14	6.63	9.94	13.26	
Y	1.07	1.60	2.41	4.01	6.42	9.63	12.84	
Z	.86	1.28	1.92	3.21	5.13	7.69	10.26	
1	.57	.86	1.28	2.14	3.43	5.14	6.86	
2	.83	1.24	1.86	3.10	4.96	7.44	9.92	
3	.82	1.23	1.85	3.08	4.93	7.39	9.86	
4	.83	1.24	1.86	3.09	4.95	7.42	9.90	
5	.82	1.23	1.85	3.07	4.92	7.38	9.84	
6	.79	1.19	1.78	2.97	4.76	7.14	9.52	
7	.76	1.14	1.70	2.84	4.55	6.82	9.10	
8	.82	1.25	1.85	3.08	4.93	7.39	9.86	
9	.79	1.19	1.78	2.97	4.76	7.14	9.52	
0	.86	1.29	1.93	3.22	5.16	7.74	10.32	
ampersand	&	1.08	1.61	2.42	4.03	6.45	9.67	12.90
dollar sign	\$.61	.91	1.36	2.27	3.64	5.46	7.28
cent sign	¢	.66	1.00	1.50	2.50	4.00	6.00	8.00
percent sign	%	.98	1.47	2.20	3.67	5.88	8.82	11.76

* Not available in die-cut letters.

**CHARACTER WIDTH TABLE (NPS MODIFIED CLARENDON)
LOWER CASE & PUNCTUATION**

	*.67"	1"	1.50"	2.50"	4"	6"	8"	
	L/C	L/C	L/C	L/C	L/C	L/C	L/C	
	(for	(for	(for	(for	(for	(for	(for	
	1"	1.50"	2.25"	3.75"	6"	9"	12"	
	U/C)	U/C)	U/C)	U/C)	U/C)	U/C)	U/C)	
a	.79	1.18	1.77	2.95	4.72	7.08	9.44	
b	.77	1.15	1.73	2.88	4.62	6.93	9.24	
c	.67	1.00	1.50	2.50	4.00	6.00	8.00	
d	.79	1.19	1.79	2.98	4.77	7.15	9.54	
e	.68	1.02	1.53	2.55	4.08	6.12	8.16	
f	.57	.85	1.28	2.13	3.41	5.11	6.82	
g	.88	1.32	1.99	3.31	5.30	7.95	10.60	
h	.82	1.23	1.85	3.08	4.93	7.39	9.86	
i	.41	.61	.92	1.53	2.45	3.67	4.90	
j	.47	.71	1.07	1.78	2.85	4.27	5.70	
k	.85	1.28	1.91	3.19	5.11	7.66	10.22	
l	.41	.61	.92	1.53	2.45	3.67	4.90	
m	1.26	1.89	2.83	4.71	7.55	11.32	15.10	
n	.82	1.22	1.84	3.06	4.90	7.35	9.80	
o	.79	1.19	1.78	2.96	4.75	7.12	9.50	
p	.79	1.19	1.78	2.96	4.75	7.12	9.50	
q	.79	1.19	1.78	2.96	4.75	7.12	9.50	
r	.60	.90	1.36	2.26	3.62	5.43	7.24	
s	.61	.91	1.36	2.27	3.64	5.46	7.28	
t	.50	.76	1.13	1.88	3.02	4.53	6.04	
u	.79	1.19	1.78	2.96	4.75	7.12	9.50	
v	.79	1.19	1.78	2.96	4.75	7.12	9.50	
w	1.14	1.71	2.57	4.28	6.85	10.27	13.70	
x	.83	1.24	1.86	3.09	4.95	7.42	9.90	
y	.86	1.28	1.92	3.20	5.13	7.69	10.26	
z	.63	.95	1.42	2.37	3.80	5.70	7.60	
comma/ semi-colon	, ;	.25	.37	.56	.93	1.50	2.25	3.00
period/ colon	. :	.22	.33	.50	.83	1.34	2.01	2.68
dash	-	.45	.67	1.00	1.66	2.67	4.00	5.34
question mark	?	.67	1.01	1.51	2.51	4.03	6.04	8.06
exclamation point	!	.24	.36	.53	.89	1.43	2.14	2.86
parenthesis	()	.30	.45	.67	1.11	1.79	2.68	3.58
quotes	" "	.54	.81	1.22	2.03	3.25	4.87	6.50
apostrophe	'	.27	.41	.61	1.02	1.63	2.44	3.25

*Not available in die-cut letters.

**SPACING CHART
UPPER CASE TO UPPER CASE**

	Second Letter											
	A	BK DL EM FN HP IR	C G O Q	J	S	T	U	V W	X	Y	Z	
A	7	7	5	6	7	4	5	1	8	1	9	
B	7	11	11	9	14	9	11	6	7	4	13	
C	6	11	13	12	14	13	12	10	9	9	13	
D	5	11	11	8	13	9	8	5	6	3	10	
E	7	13	13	9	14	12	11	7	10	7	14	
F	1	9	9	6	12	9	8	6	8	5	12	
G	4	9	8	6	10	8	6	4	6	3	9	
H,I,M	7	11	11	7	13	10	9	6	7	6	13	
J	2	9	8	5	10	9	9	7	7	6	13	
K	6	7	6	4	7	6	7	4	7	3	8	
L	7	10	8	7	12	5	4	3	7	2	9	
N	3	9	7	4	10	8	8	6	6	4	10	
O	5	11	11	8	13	9	8	5	6	3	10	
P	1	7	8	2	9	8	5	4	4	4	7	
Q	6	8	9	8	12	6	8	2	5	2	10	
R	6	8	9	8	12	6	8	2	5	2	10	
S	6	10	13	8	13	8	8	5	7	4	12	
T	4	7	9	5	11	10	9	7	7	6	10	
U	2	9	8	5	10	9	9	7	7	6	13	
V,W	1	6	5	1	8	7	7	7	6	5	8	
X	6	7	6	4	7	6	7	4	7	3	8	
Y	1	6	4	1	8	6	6	5	3	5	7	
Z	9	13	10	10	14	10	13	8	8	7	13	

**SPACING CHART
UPPER CASE TO LOWER CASE**

		Second Letter																										
		a	b	c																								
First Letter		h	d						m						v													
		k	e	f	g	i	j	n	p	s	t	u	w	x	y	z												
	l	o	q				r																					
A	5	6	4	7	4	5	3	5	4	6	4	3	1	4	2	6												
B	9	11	8	9	8	8	3	8	8	11	8	8	6	6	6	11												
C	9	11	9	9	8	9	3	7	12	8	8	9	6	7	5	11												
D	9	11	9	10	8	9	3	8	9	11	8	6	6	7	4	11												
E	12	13	10	12	9	11	5	11	10	13	10	10	8	9	8	13												
F	4	9	3	7	3	7	1	6	4	6	5	4	4	4	4	7												
G	8	9	7	10	7	7	2	8	8	9	8	6	6	6	5	8												
H,I,M	7	11	7	8	7	7	3	9	6	11	6	6	4	6	5	9												
J	5	9	4	5	3	6	1	4	5	7	4	4	3	3	3	6												
K	5	7	3	6	6	6	3	6	4	3	8	3	3	5	3	8												
L	9	10	8	10	7	9	6	9	7	12	6	7	4	7	5	10												
N	4	9	5	6	10	5	1	4	4	7	6	5	3	5	4	7												
O	9	11	9	10	8	9	3	8	9	11	8	6	6	7	4	11												
P	3	7	3	4	3	6	1	4	4	5	4	4	4	3	4	4												
Q	7	8	7	7	6	7	3	5	5	9	5	4	3	5	3	9												
R	7	8	7	7	6	7	3	5	5	9	5	4	3	5	3	9												
S	9	10	8	9	8	9	3	8	8	11	8	7	6	6	5	10												
T	4	7	4	7	4	7	3	6	6	6	5	5	5	5	4	7												
U	5	9	4	5	3	6	1	4	5	7	4	4	3	3	3	6												
V,W	1	6	1	3	1	2	0	3	2	3	3	2	2	2	3	3												
X	5	7	3	6	6	6	3	6	4	3	8	3	3	5	3	8												
Y	1	6	1	3	0	2	0	1	1	3	2	2	1	1	1	2												
Z	12	13	10	12	9	11	5	10	8	13	8	9	6	9	7	13												

**SPACING CHART
UPPER CASE TO PUNCTUATION**

First Letter	Second Character									
	· :	“ ’	” ’	!	?	-	()	&	
A	6	3	3	8	3	6	10	7	4	
B	7	4	4	13	8	10	14	11	9	
C	8	9	9	14	10	10	14	10	10	
D	8	8	8	14	10	13	13	11	13	
E	10	7	7	14	10	13	14	13	12	
F	6	7	7	13	8	6	13	9	8	
G	7	4	4	9	5	10	13	9	9	
H,I,M	6	7	7	13	8	8	14	11	9	
J	5	7	7	11	7	7	12	9	7	
K	6	6	6	8	4	6	8	7	5	
L	9	6	6	11	6	10	14	10	11	
N	5	6	6	10	6	5	12	9	8	
O	8	8	8	14	10	13	13	11	13	
P	4	6	6	11	8	7	11	7	5	
Q	6	4	4	11	6	7	11	8	8	
R	6	4	4	11	6	7	11	8	8	
S	7	4	4	12	7	10	14	10	11	
T	7	7	7	13	8	6	11	7	7	
U	5	7	7	11	7	7	12	9	7	
V,W	3	6	6	10	6	4	10	6	3	
X	6	6	6	8	4	6	8	7	5	
Y	3	6	6	8	6	3	9	6	2	
Z	10	8	8	13	8	11	13	13	11	

**SPACING CHART
UPPER CASE TO FIGURES**

		Second Figure											
First Letter		1	2	3	4	5	6	% 7	8	9	0	€	\$
	A		6	7	6	3	7	5	4	6	5	5	2
B		10	10	9	7	10	9	6	10	9	9	8	10
C		10	13	12	9	12	13	10	13	12	13	10	13
D		8	10	8	8	11	9	9	9	9	9	10	13
E		13	13	13	11	13	13	10	13	13	13	11	13
F		6	7	7	3	8	7	7	9	9	7	7	8
G		7	8	9	7	8	9	8	10	9	9	8	10
H,I,M		9	12	9	6	11	11	8	11	10	11	7	11
J		7	7	7	6	8	7	7	11	9	8	8	9
K		5	7	6	3	8	6	7	7	6	6	4	6
L		8	9	8	7	9	9	6	10	9	9	6	10
N		6	11	8	4	8	9	7	9	8	9	7	9
O		8	10	8	8	11	9	9	9	9	9	10	13
P		6	7	7	3	6	6	6	6	8	6	6	7
Q		7	8	8	6	9	8	5	8	9	8	7	7
R		7	8	8	6	9	8	5	8	9	8	7	7
S		9	10	8	6	11	10	7	10	10	10	8	10
T		7	7	8	4	8	9	8	9	11	9	7	8
U		7	7	7	6	8	7	7	11	9	8	8	9
V,W		5	6	4	2	5	5	5	6	5	5	3	5
X		5	7	6	3	8	6	7	7	6	6	4	6
Y		6	6	4	3	7	3	6	4	4	3	4	6
Z		11	12	13	10	12	10	10	13	10	10	12	12

**SPACING CHART
LOWER CASE TO UPPER CASE**

	Second Letter											
	A	BK DL EM FN HP IR	C G O Q	J	S	T	U	V W	X	Y	Z	
a	5	7	7	6	10	3	5	1	4	1	8	
b,e,o,p	4	11	10	8	11	4	4	1	3	1	10	
c	6	7	12	9	11	5	7	3	5	3	10	
d,l	7	9	10	6	11	7	8	4	7	3	11	
f	2	6	7	3	8	6	6	5	5	4	10	
g	2	4	8	6	9	5	4	1	3	1	7	
h,m,n	6	6	8	6	10	4	6	2	6	1	10	
i	7	7	9	6	10	6	4	3	7	3	9	
j	7	13	11	10	13	8	9	6	8	4	12	
k	4	6	7	6	10	5	3	2	5	1	9	
q	4	6	9	7	11	6	6	2	4	1	8	
r	3	4	10	5	11	6	5	2	4	2	9	
s	7	10	10	8	13	5	9	4	7	1	12	
t	6	8	10	6	11	6	7	3	6	2	10	
u	5	7	10	7	11	3	7	3	6	2	10	
v,w	1	4	6	4	10	5	3	2	3	1	9	
x	4	6	7	6	10	5	3	2	5	1	9	
y	1	4	6	4	10	5	3	2	3	1	9	
z	6	11	11	8	13	7	6	3	8	2	13	

SPACING CHART
LOWER CASE TO LOWER CASE

		Second Letter																																											
		a	b	c																																									
First Letter		l	k	o	f	g	i	j	m	n	p	s	t	u	v	w	x	y	z	a	b	c	d	e	f	g	h	i	j	k	l	m	n	o	p	q	r	s	t	u	v	w	x	y	z
	a	6	6	6	5	5	4	1	4	3	7	3	4	3	5	2	7	6	6	5	8	6	8	4	7	5	8	6	7	5	6	5	9												
b,e,o,p	8	7	7	7	9	7	1	7	6	11	6	7	5	5	5	9	8	7	7	7	9	7	1	7	6	11	6	7	5	5	5	9													
c	8	7	7	7	9	7	1	7	6	11	6	7	5	5	9	8	7	7	7	9	7	1	7	6	11	6	7	5	5	5	9														
d,l	6	9	7	7	8	7	2	8	6	10	6	7	4	6	4	9	6	9	7	7	8	7	2	8	6	10	6	7	4	6	4	9													
f	3	6	3	4	3	4	1	3	2	4	2	3	3	3	2	6	3	6	3	4	3	4	1	3	2	4	2	3	3	3	2	6													
g	6	4	4	6	4	7	3	6	4	7	4	6	4	4	4	7	6	4	4	6	4	7	3	6	4	7	4	6	4	4	4	7													
h,m,n	7	6	6	8	6	7	3	7	6	10	5	6	4	6	4	9	7	6	6	8	6	7	3	7	6	10	5	6	4	6	4	9													
i	7	7	7	8	6	6	3	6	6	8	6	6	4	4	5	9	7	7	7	8	6	6	3	6	6	8	6	6	4	4	5	9													
j	10	13	10	11	9	10	5	10	9	13	9	9	7	8	7	12	10	13	10	11	9	10	5	10	9	13	9	9	7	8	7	12													
k	6	6	5	8	6	8	4	7	5	8	6	7	5	6	5	8	6	6	5	8	6	8	4	7	5	8	6	7	5	6	5	8													
q	7	6	6	7	8	7	4	8	6	9	5	6	6	5	7	8	7	6	6	7	8	7	4	8	6	9	5	6	6	5	7	8													
r	6	4	5	7	5	7	3	7	5	8	7	6	6	5	5	9	6	4	5	7	5	7	3	7	5	8	7	6	6	5	5	9													
s	10	10	11	10	9	9	3	9	8	11	9	10	7	8	5	10	10	10	11	10	9	9	3	9	8	11	9	10	7	8	5	10													
t	8	8	8	9	8	7	3	9	8	10	7	8	5	6	4	12	8	8	8	9	8	7	3	9	8	10	7	8	5	6	4	12													
u	8	7	8	8	8	7	1	7	6	9	6	5	4	5	2	7	8	7	8	8	8	7	1	7	6	9	6	5	4	5	2	7													
v,w	5	4	5	6	7	6	1	6	6	7	6	4	5	5	4	7	5	4	5	6	7	6	1	6	6	7	6	4	5	5	4	7													
x	6	6	5	8	6	8	4	7	5	8	6	7	5	6	5	8	6	6	5	8	6	8	4	7	5	8	6	7	5	6	5	8													
y	5	4	5	6	7	6	1	6	6	7	6	4	5	5	4	7	5	4	5	6	7	6	1	6	6	7	6	4	5	5	4	7													
z	10	11	9	10	10	10	4	10	8	12	9	9	7	8	6	11	10	11	9	10	10	10	4	10	8	12	9	9	7	8	6	11													

**SPACING CHART
LOWER CASE TO PUNCTUATION**

		Second Character								
		./ :	"	'	!	?	-	()	&
First Letter	a	6	3	3	8	3	7	12	6	8
	b,e,o,p	7	4	4	11	5	10	12	7	11
	c	8	4	4	10	6	11	13	7	10
	d,l	6	3	3	10	7	8	12	9	8
	f	3	6	6	8	7	4	8	6	6
	g	7	4	4	10	6	7	11	4	8
	h,m,n	6	3	3	10	4	8	13	6	9
	i	5	4	4	9	5	8	11	7	8
	j	9	7	7	12	9	11	14	13	10
	k	7	4	4	8	6	8	10	6	8
	q	8	6	6	11	10	9	13	6	8
	r	8	4	4	9	7	9	10	4	8
	s	9	4	4	12	8	10	13	10	10
	t	8	6	6	9	6	9	12	8	12
	u	6	3	3	10	4	9	12	7	8
	v,w	7	5	5	9	6	7	11	4	7
	x	7	4	4	8	6	8	10	6	8
	y	7	5	5	9	6	7	11	4	7
	z	8	7	7	11	8	12	13	11	10

SPACING CHART
LOWER CASE TO FIGURES

Second Figure

	%											
	1	2	3	4	5	6	7	8	9	0	\$	
a	5	7	7	5	7	6	4	7	5	6	7	
b,e,o,p	7	9	9	6	9	10	5	8	9	10	10	
c	9	12	10	8	11	11	7	10	11	11	10	
d,l	7	10	8	6	10	9	8	9	10	9	9	
f	6	8	8	4	7	7	8	7	7	7	7	
g	4	9	7	5	7	7	6	8	8	7	8	
h,m,n	6	9	6	6	8	7	4	8	8	8	9	
i	6	8	8	4	8	8	5	8	9	8	9	
j	9	12	10	9	11	13	8	13	12	13	12	
k	6	9	8	6	8	7	7	6	8	7	9	
q	7	10	10	7	10	9	8	8	9	9	10	
r	8	9	9	6	9	10	7	9	8	10	10	
s	8	8	10	7	10	10	7	10	9	10	11	
t	10	10	10	8	10	11	8	10	11	11	10	
u	6	9	9	5	9	9	4	9	8	9	10	
v,w	6	9	8	5	7	6	7	6	8	6	10	
x	6	9	8	6	8	7	7	6	8	7	9	
y	6	9	8	5	7	6	7	6	8	6	10	
z	10	12	11	10	12	11	8	11	11	11	12	

**SPACING CHART
PUNCTUATION TO LOWER CASE**

Second Letter

				c															
		a	b	d	e	f	g	i	j	m	n	p	s	t	u	v	x	y	z
First Character	;	7	6	7	8	8	8	5	8	8	10	7	8	7	7	7	8		
	'	4	7	4	6	2	9	1	7	6	6	7	6	5	3	4	7		
	"	4	7	4	6	2	9	1	7	6	6	7	6	5	3	4	7		
	!	10	13	11	13	9	11	6	10	11	13	13	11	9	8	8	11		
	?	5	9	5	7	4	8	2	7	7	7	7	5	5	5	5	8		
	-	9	8	10	10	8	10	3	8	9	11	8	0	7	8	6	12		
	(7	11	7	8	7	7	3	9	6	11	6	6	4	6	5	11		
)	13	14	12	12	12	12	5	13	13	13	11	11	4	10	7	13		
	&	10	11	10	9	9	11	5	10	10	11	9	8	7	8	6	13		

**SPACING CHART
PUNCTUATION TO UPPER CASE**

Second Letter

				BK													
		A	BK	C	DL	EM	FN	HP	O	J	S	T	U	V	X	Y	Z
First Character	;	6	6	8	6	8	7	5	3	6	3	10					
	'	3	7	8	0	6	7	7	6	6	6	8					
	"	3	7	8	0	6	7	7	6	6	6	8					
	!	8	13	14	6	13	13	11	10	8	8	13					
	?	1	9	7	4	9	6	7	4	5	4	8					
	-	6	8	13	7	10	6	7	4	6	3	11					
	(7	11	11	7	13	10	9	6	7	6	13					
)	10	14	13	7	13	11	12	10	8	9	13					
	&	6	11	10	7	9	5	6	3	4	3	10					

**SPACING CHART
PUNCTUATION TO PUNCTUATION**

		Second Character								
		⋮ ⋮ ⋮	” ’	” ’	!	?	-	()	&
First Character	⋮ ⋮ ⋮	10	6	6	13	7	10	13	6	10
	”	6	10	10	11	8	6	11	7	3
	”	6	10	10	11	8	6	11	7	3
	!	13	11	11	13	10	10	14	13	10
	?	6	6	6	10	8	7	12	9	6
	-	10	6	6	10	5	12	13	8	12
	(6	7	7	13	8	8	14	11	9
)	13	11	11	14	12	13	14	14	13
	&	10	6	6	13	8	13	14	11	12

**SPACING CHART
PUNCTUATION TO FIGURES**

		Second Figure										
		1	2	3	4	5	6	%	7	8	9	0
First Character	⋮ ⋮ ⋮	7	8	8	5	6	7	5	7	8	7	12
	”	8	8	7	3	6	8	6	4	4	8	8
	”	8	8	7	3	6	8	6	4	4	8	8
	!	10	13	13	10	13	14	12	13	13	14	14
	?	8	10	7	6	8	9	9	10	10	9	11
	-	9	11	8	10	13	13	9	10	11	13	11
	(9	12	9	6	11	11	8	11	10	11	11
)	10	13	13	12	14	13	13	14	11	13	13
	&	11	11	11	8	10	11	9	10	13	11	13

**SPACING CHART
FIGURES TO LOWER CASE**

Second Letter

First Figure	b		c		f	g	i	j	m		p	s	t	u	v		x	y	z
	a	h	d	e					n	r					w				
1	6	7	4	7	6	5	1	4	4	7	4	3	2	5	3	8			
2	10	10	8	10	9	9	4	8	10	12	8	7	6	7	5	11			
3	9	11	8	9	8	8	3	8	8	11	8	8	6	6	6	11			
4	9	9	8	9	7	8	3	9	7	10	6	7	4	6	5	10			
5	9	10	8	9	7	9	4	9	10	10	7	7	4	6	6	10			
6	10	10	9	10	8	9	3	8	9	11	8	8	6	7	6	10			
7	3	6	3	5	1	3	1	3	3	3	4	3	2	1	2	4			
8	9	11	8	9	8	8	3	8	8	11	8	8	6	6	6	11			
0,9	9	11	9	10	8	9	3	8	9	11	8	6	6	7	4	11			
d	9	7	8	10	8	8	3	8	10	9	9	7	6	7	7	10			

**SPACING CHART
FIGURES TO UPPER CASE**

Second Letter

First Figure	A	BK		J	S	T	U	V		X	Y	Z
		DL	EM					W	X			
1	6	7	4	5	8	3	3	2	6	1	7	
2	7	10	9	7	13	7	9	4	6	2	10	
3	7	11	11	9	14	9	11	6	7	4	13	
4	7	9	8	7	10	4	6	2	5	3	10	
5	4	10	9	7	11	8	7	4	6	3	11	
6	5	10	9	8	13	7	8	5	6	4	10	
7	1	6	5	1	8	4	6	4	3	4	7	
8	7	11	11	9	14	9	11	6	7	4	13	
0,9	5	11	9	8	13	9	8	5	6	3	10	
d	4	10	10	9	12	7	8	4	4	3	9	

**SPACING CHART
FIGURES TO PUNCTUATION**

		Second Character								
		·	”	”	!	?	-	()	&
First Figure	1	6	3	3	8	5	8	9	7	9
	2	8	6	6	11	8	10	14	10	11
	3	7	4	4	13	8	10	14	11	9
	4	8	4	4	10	6	12	14	9	11
	5	9	4	4	11	7	12	14	10	11
	6	10	4	4	12	9	13	11	10	11
	%7	6	7	7	8	7	6	11	6	4
	8	7	4	4	13	8	10	14	11	9
	0,9	8	8	8	14	10	13	13	11	13
	¢	8	4	4	10	6	11	13	10	10

**SPACING CHART
FIGURES TO FIGURES**

		Second Figure												
		1	2	3	4	5	6	%	7	8	9	0	¢	\$
First Figure	1	6	6	6	3	8	4	4	6	5	4	6	6	
	2	10	11	10	7	10	9	7	10	9	9	10	11	
	3	10	10	9	7	10	9	6	10	9	9	8	10	
	4	7	11	8	7	9	8	5	9	8	8	8	9	
	5	8	10	9	7	8	9	7	10	10	9	8	12	
	6	10	8	11	6	11	9	7	9	9	9	9	11	
	7	6	6	5	2	5	5	6	5	5	5	4	5	
	8	10	10	9	7	10	9	6	10	9	9	8	10	
	0,9	9	11	8	7	10	9	8	9	9	9	10	13	
	\$	10	11	11	7	11	10	11	10	11	10	10	11	
¢	9	12	10	8	10	10	8	11	10	10	9	12		

ARROW SPECIFICATIONS

LETTER SIZE (UPPER CASE)	A	B	C	D	E	G	H
1/2"	3/16"	7/32"	3/8"	1/32"	1/32"	3/4"	1/2"
3/4"	9/32"	5/16"	9/16"	3/64"	1/16"	1-1/8"	3/4"
1"	3/8"	7/16"	3/4"	1/16"	5/64"	1-1/2"	1-1/32"
1-1/2"	9/16"	5/8"	1-1/8"	1/8"	1/8"	2-1/4"	1-1/2"
2-1/4"	7/8"	1"	1-3/4"	3/16"	3/16"	3-1/2"	2-3/8"
3-3/4"	1-7/16"	1-5/8"	2-7/8"	3/16"	1/4"	5-5/8"	3-3/4"
6"	2-1/4"	2-5/8"	4-1/2"	3/8"	7/16"	9"	6-1/8"
9"	3-5/16"	3-13/16"	6-11/16"	1/2"	11/16"	13-5/16"	9"
12"	4-1/2"	5-3/16"	9-1/8"	11/16"	7/8"	18-1/8"	12-1/8"

STANDARD HIGHWAY SIGN ARROW DESIGN

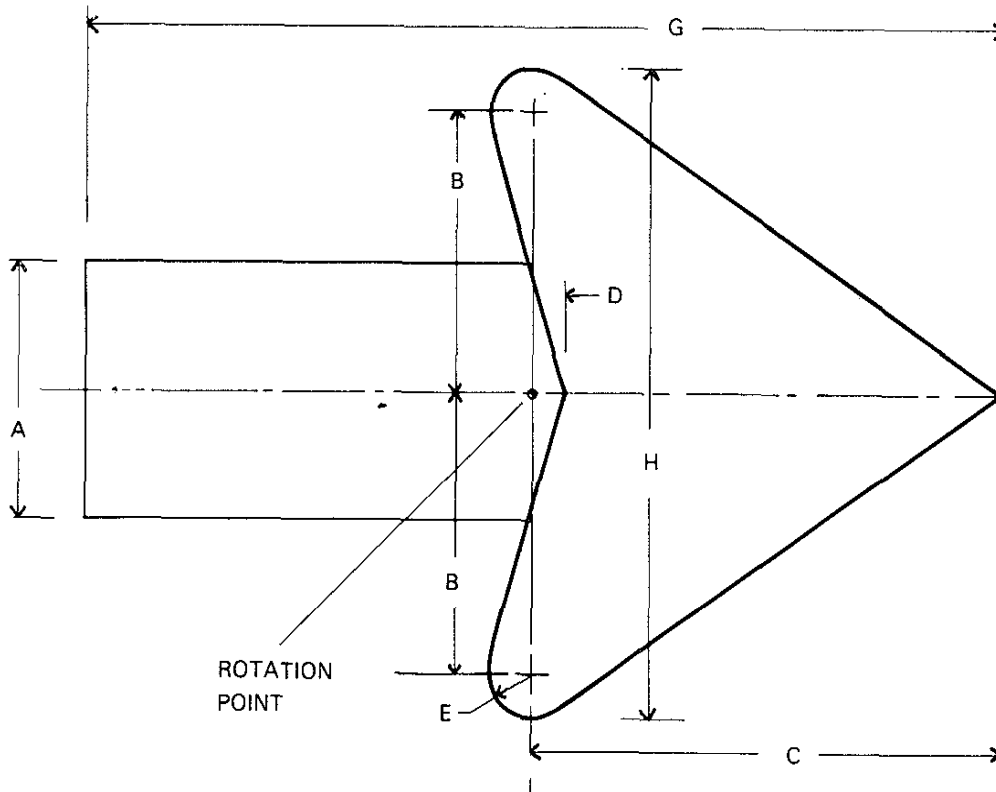

ROAD SIGN - CATEGORY 1-3

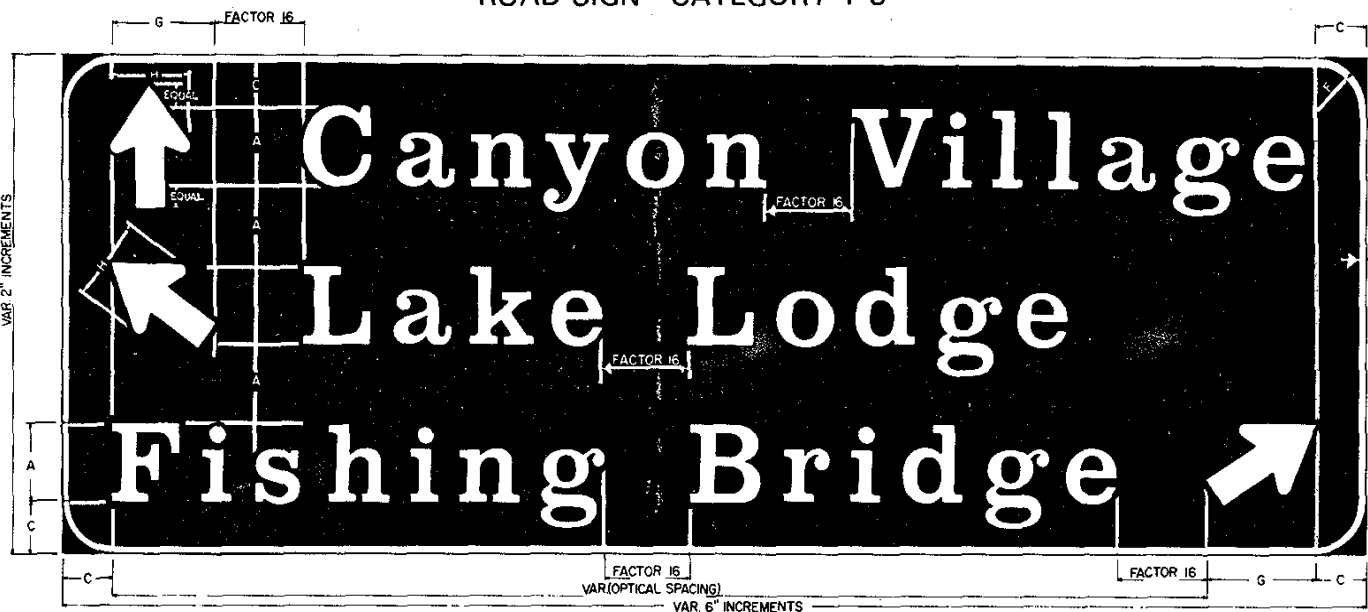

5-29

ROAD SIGN – CATEGORY 2--3

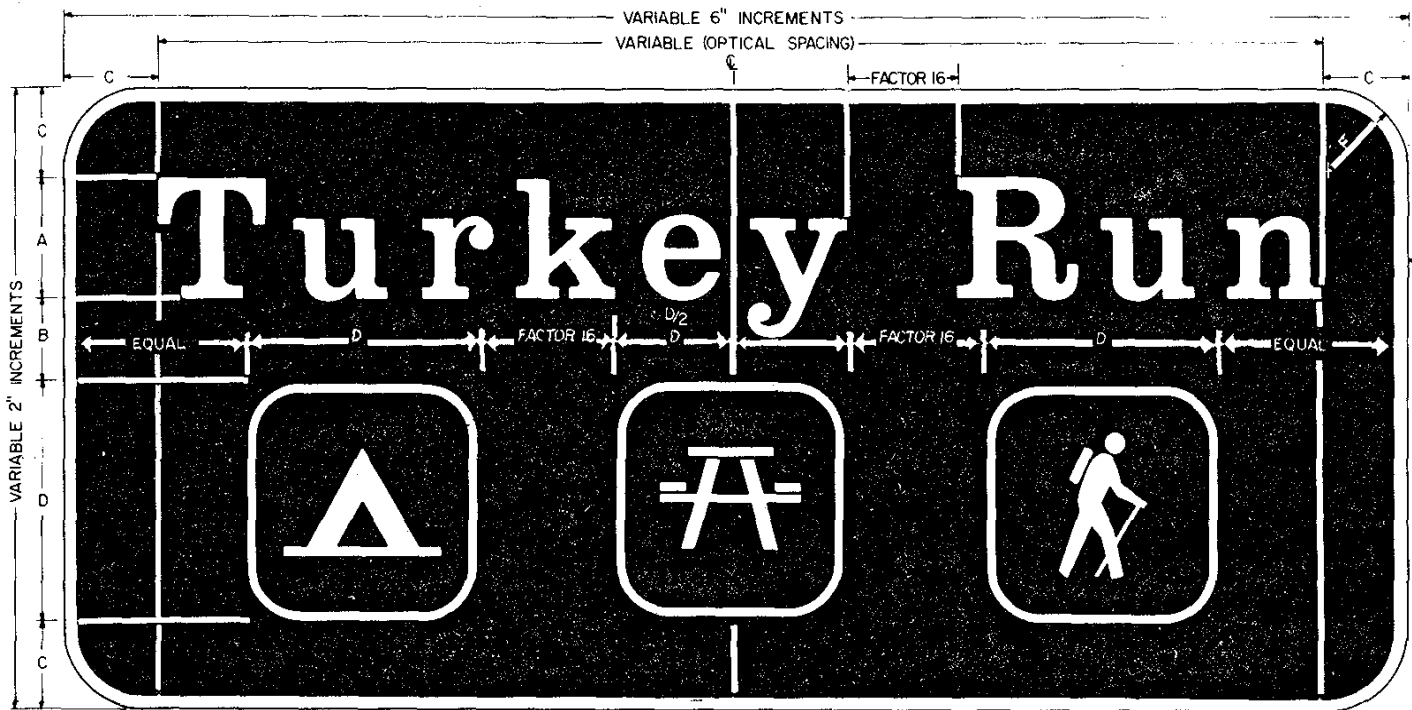

5-30

ROAD SIGN – CATEGORY 1–3

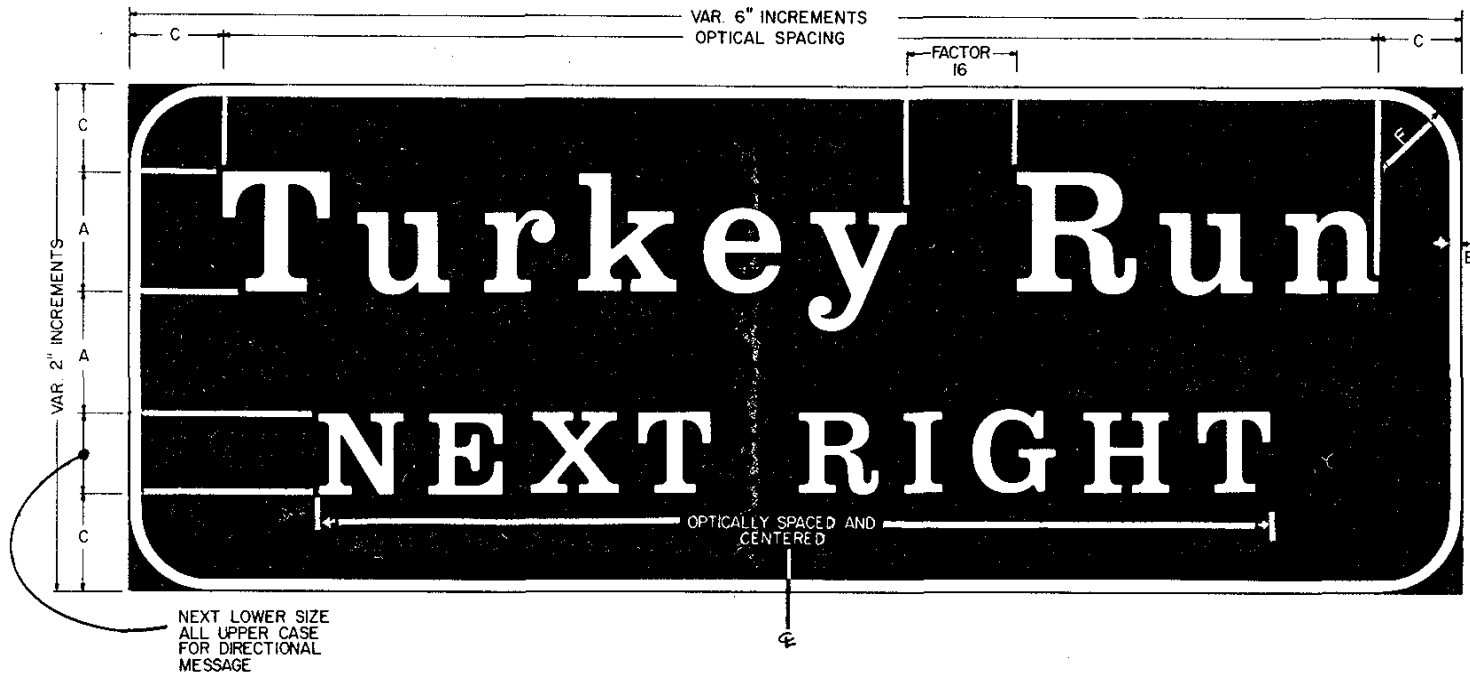

ENTRANCE SIGN - CATEGORY 1-3

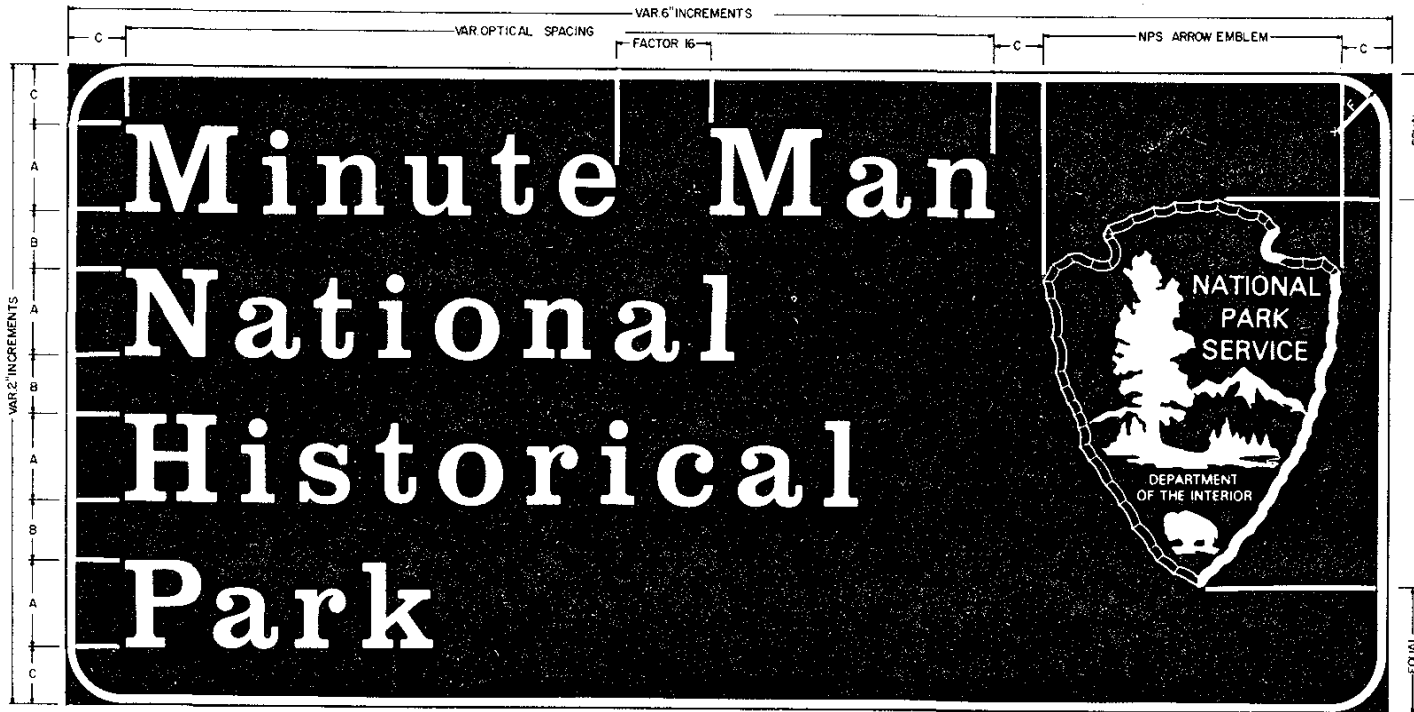

5-32

ROAD SIGN – CATEGORY 1-3

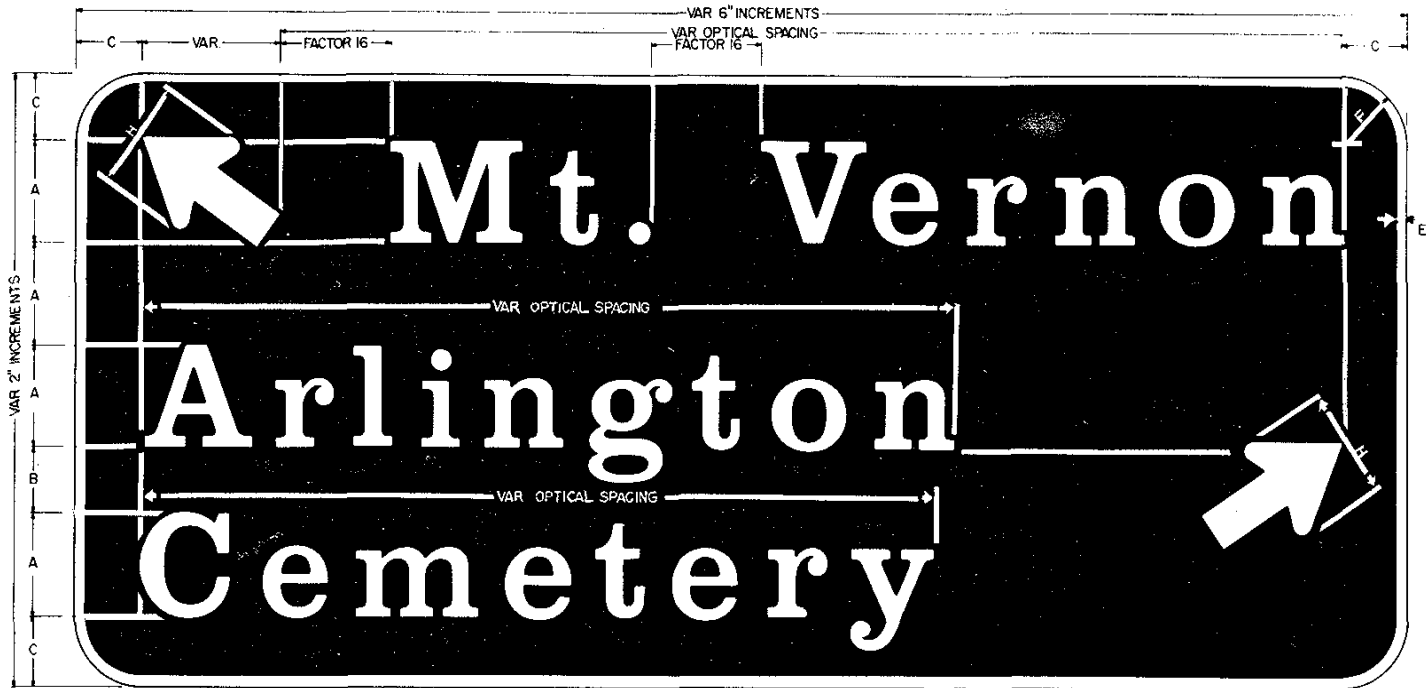

5-33

PEDESTRIAN / TRAIL SIGN – CATEGORY OTHER
(ROUTED SIGNS)

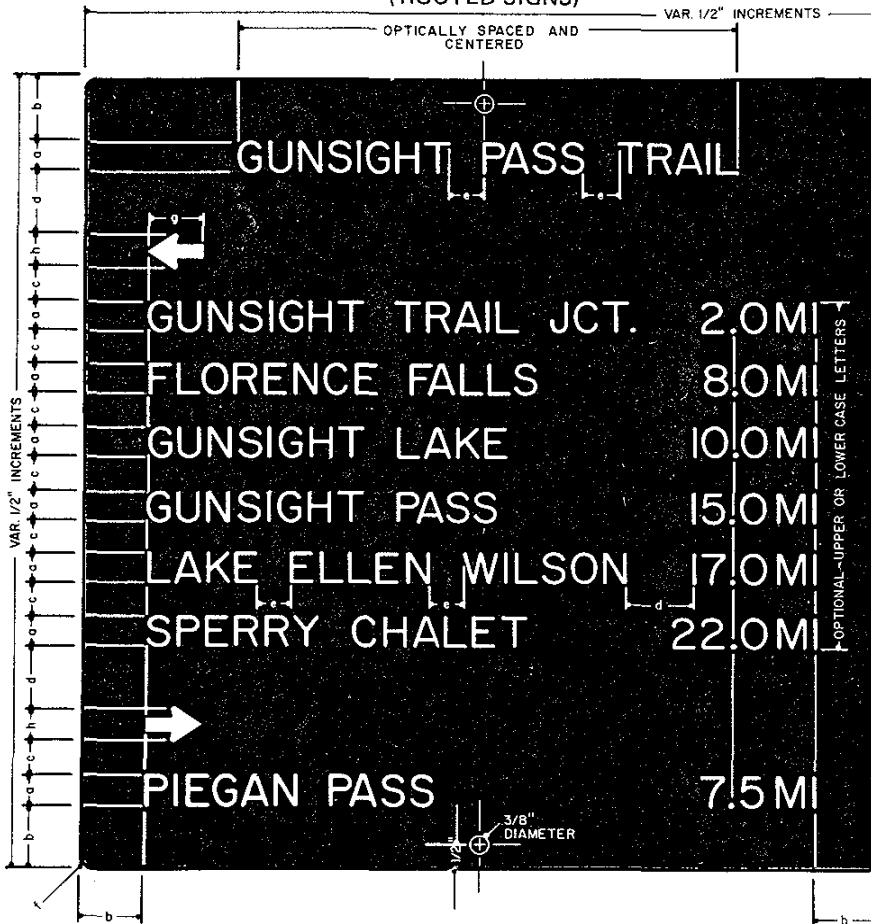

Pickett's Charge

On July 3, 1863 fifteen thousand Confederates, emerging from the woods on the left, attacked the Union line behind the stone wall on the right. The charge, climax of the battle, was repulsed with a loss of nearly ten thousand men.

NATIONAL PARK SERVICE ROUTE MARKER



Standard size 15" diameter 3 3/4" caps & numerals

3/4" wide border white on brown color

OFFICIAL NATIONAL PARK SERVICE EMBLEM



U. S. DEPARTMENT OF THE INTERIOR

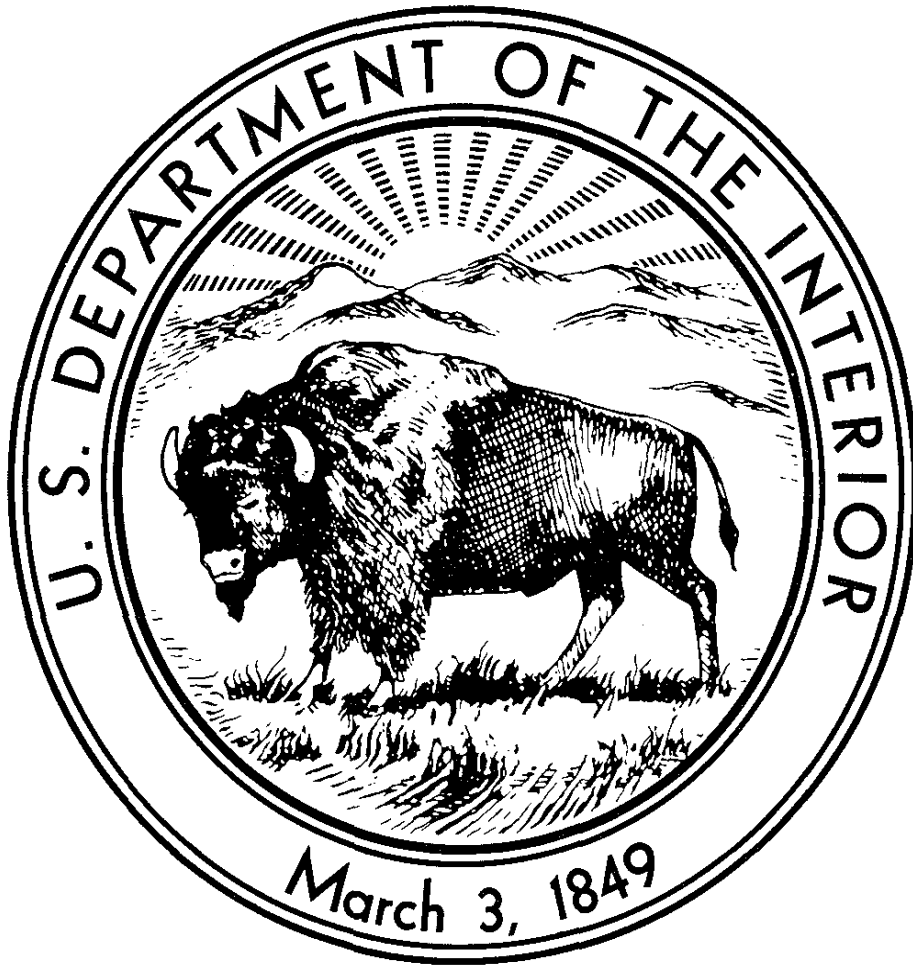

U. S. FEE AREA SYMBOL

Available in 18" & 9" sizes

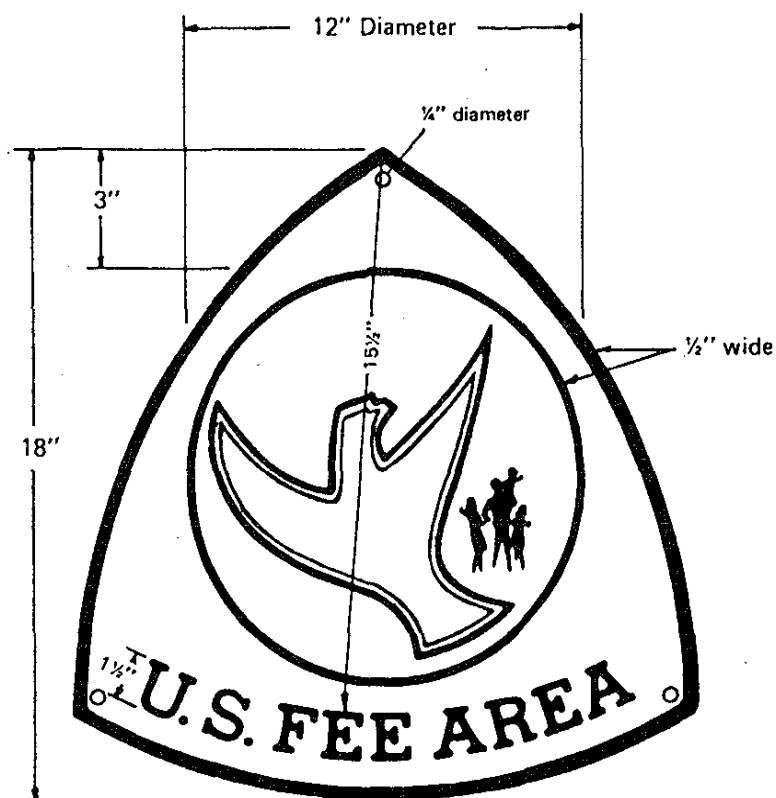

NOTE: For 9" symbol, all dimensions are half of 18" size

COLOR KEY

1. Background and Eagle – Gold Scotchlite / ReflectORIZED Paint / PMS 130
2. Background Circle – White
3. Borders, Figures, and Type – Midnight Blue / PMS 282

SIGN MATERIAL – .032" Aluminum

SOURCE: Federal Register, Vol. 39, No: 180, Monday, Sep. 16, 1974.

PACIFIC CREST TRAIL

Available in 18", 9" & 3½" sizes



APPALACHIAN TRAIL

Available in 18", 9" & 3½" sizes



NORTH COUNTRY TRAIL

Available in 18", 9" & 3½" sizes



CHAPTER 6 SPECIFICATIONS FOR MANUFACTURE OF SIGNS

CONTENTS

6-10	DESCRIPTION OF STANDARDS AND OPTIONS
6-20	REFLECTORIZED SIGNS
6-30	ROUTED WOOD SIGNS
6-40	NATIONAL PARK SERVICE (NPS) ARROWHEAD EMBLEMS
6-50	PACKAGING, ORDERING, SHIPPING
6-60	APPLICABLE DOCUMENTS, PUBLICATIONS, AND STANDARDS
6-70	QUALITY CONTROL
6-80	SIGN MOUNTING HARDWARE AND MISCELLANEOUS APPURTENANCES

NOTE:

THE MENTION OF COMPANY AND/OR PRODUCT NAMES IN THIS MANUAL IS INTENDED SOLELY FOR GUIDANCE, AND IS NOT TO BE CONSTRUED AS MANDATORY, OR AN ENDORSEMENT IN ANY MANNER BY THE NATIONAL PARK SERVICE.

INDIVIDUAL CONTRACTING OFFICERS ARE RESPONSIBLE FOR INSURING THAT FEDERAL PROCUREMENT REGULATIONS ARE FOLLOWED FOR EACH INDIVIDUAL PROCUREMENT.

6-10 DESCRIPTION OF STANDARDS AND OPTIONS

CONTENTS

6-11	EXPLANATION OF STANDARD BASIC SIGNS AND OPTIONS
6-11.10	TRAFFIC CONTROL SIGNS
6-11.11	Basic Sign
6-11.12	Options
6-11.20	GUIDE, INFORMATIONAL, AND ENTRANCE SIGNS (VEHICULAR SIGNS)
6-11.21	Basic Sign
6-11.22	Options
6-11.30	PEDESTRIAN DIRECTION SIGNS
6-11.31	Basic Design
6-11.32	Options
6-11.40	NPS ARROWHEAD EMBLEMS
6-11.41	Basic Design
6-11.42	Options

6-10 DESCRIPTION OF STANDARDS AND OPTIONS

6-11 EXPLANATION OF STANDARD BASIC SIGNS AND OPTIONS.

Basic sign compositions are described below to enable the sign manufacturer to develop unit prices for contract work.

6-11.10 TRAFFIC CONTROL SIGNS

6-11.11 Basic Sign

- a. *Color:* As specified in MUTCD.
- b. *Copy:* As specified in MUTCD.
- c. *Size:* As specified in MUTCD and Standard Highway Signs Book unless otherwise specified.
- d. *Substrate:* High density overlay (HDO) plywood.
- e. *Reflectivity:* Reflective sheeting with silkscreen copy and border.
- f. *Edges:* Painted dark brown.
- g. *Sign Back:* Unpainted.
- h. Transparent film on top edge of sign.

6-11.12 Options

- a. *Substrate:* Aluminum, FRP panel (polyplate).
- b. *Copy:* Die-cut alphabets, numerals, arrows, and symbols.
- c. *Sign Back:* Painted brown.

6-11.20 GUIDE, INFORMATIONAL, AND ENTRANCE SIGNS (VEHICULAR SIGNS)

6-11.21 Basic Sign

- a. *Color:* White legend and border on brown background.
- b. *Copy:* NPS Modified Clarendon alphabet.
- c. *Size:* As determined using NPS Modified Clarendon lettering and spacing, for the designated sign category.
- d. *Substrate:* High density overlay (HDO) plywood.
- e. *Reflectivity:* Reflective sheeting background with die-cut reflective legend and borders.
- f. *Edges:* Painted dark brown.
- g. *Sign Back:* Unpainted.
- h. Transparent film on top edge of sign.

6-11.22 Options

- a. Aluminum or FRP panel substrate.
- b. Sign back painted dark brown.
- c. Dimensional lumber with routed copy, painted or stained background and nonreflective painted copy (entrance sign only).
- d. Routed HDO plywood, painted. Copy on one side only, unless otherwise specified (entrance sign only).
- e. White legend and border on green background, standard highway alphabet as specified in MUTCD.
- f. Any standard approved alphabet.

6-11.30 PEDESTRIAN DIRECTION SIGNS

6-11.31 Basic Design

- a. *Color:* White legend and border on brown background.
- b. *Copy:* NPS Modified Clarendon alphabet.
- c. *Size:* As determined using NPS Modified Clarendon lettering and spacing, for the designated sign category.
- d. *Substrate:* High-density overlay (HDO) plywood.
- e. *Reflectivity:* Reflective sheeting background with die-cut or silkscreened reflective legend and borders.

- f. *Edges:* Painted dark brown.
- g. *Sign Back:* Unpainted.
- h. Transparent film on top edge of sign.

6-11.32

Options

- a. *Substrate:* Dimensional lumber, anodized aluminum, aluminum plate.
- b. *Routed Copy:* NPS Modified Clarendon, Engineering Standard or an approved standard alphabet. (Painted, natural or burned finish).

6-11.40

NPS ARROWHEAD EMBLEMS

6-11.41

Basic Design

- a. *Substrate:* Dimensional lumber.
- b. *Copy/Art Work:* Routed letters and graphics, photographically reproduced from NPS drawing no. PG-1005-A.
- c. *Size:* As determined by NPS Sign Manual.
- d. *Painted Colors: matching Federal Standard 595a*

Background	Cocoa brown	#20233
Trees and buffalo outline	Dark blue/green	#34058
Mountain and lake	Cream	#23690
Lettering	White	#17875

6-11.42

Options

- a. HDO plywood substrate with routed and painted copy and artwork.
- b. High-density rigid polyurethane foam substrate with molded and painted copy and artwork.
- c. Silkscreened decal on reflective or non-reflective sheeting.

6-20 REFLECTORIZED SIGNS

CONTENTS

6-21	REFLECTORIZED SIGNS
6-21.10	DESCRIPTION
6-22	MATERIALS
6-22.10	SUBSTRATE
6-22.11	Aluminum
6-22.12	Plywood
6-22-20	REFLECTIVE MATERIALS
6-22.21	Reflective Background, Legend, Border, and Symbols
6-22.21a	<i>Retroreflective Sheeting – Type II</i>
6-22.21b	<i>Retroreflective Sheeting – Type III</i>
6-22.21c	<i>Legend, Border, and Symbols</i>
6-22.22	<i>Top Edge Treatment Film</i>
6-22.30	TREATMENT OF PLYWOOD SIGN EDGES
6-22.31	Wood Primer
6-22.32	Enamel
6-23	CONSTRUCTION
6-23.10	WORKMANSHIP
6-23.20	WOODWORKING
6-23.21	Board Joining and Cleating
6-23.22	Machining
6-23.23	Dimension Tolerances
6-23.24	Edge Sanding and Finishing
6-23.25	Panel Surfaces
6-23.26	Plywood Storage and Handling
6-23.30	PREPARING PLYWOOD PANELS FOR RETROREFLECTIVE SHEETING
6-23.31	Sanding and Cleaning
6-23.32	Paint Room Facilities
6-23.33	Priming and Enamel Application

6-23.34	Panel Face Cleaning
6-23.40	METALWORKING
6-23.41	Surface Preparation
6-23.50	RETROREFLECTIVE SHEETING
6-23.51	Colors
6-23.52	Application Methods
6-23.60	RETROREFLECTIVE LEGEND
6-23.61	Legend Type
6-23.62	Use of Positionable Legend
6-23.63	Legend Series
6-23.64	Legend Spacing and Layout
6-23.64a	<i>Spacing and Layout for Standard Traffic Signs</i>
6-23.64b	<i>Spacing and Layout for Modified Clarendon Lettering</i>
6-23.65	Tolerance for Horizontal Alignment
6-23.66	Tolerance for Vertical Placement
6-23.70	NONREFLECTIVE LEGEND
6-23.71	Legend Series
6-23.72	Tolerance for Horizontal and Vertical Alignment
6-23.73	Tolerance for Vertical Alignment
6-23.74	Silkscreening
6-23.80	TOP EDGE TREATMENT
6-24	SURFACES
6-24.10	SILKSCREENING
6-25	DECALS AND MARKINGS
6-25.10	ANTIVANDALISM DECALS
6-25.20	MAKER'S MARK
6-25.30	INSTALLATION DATE MARK
6-26	METHOD OF MEASUREMENT
6-27	BASIS OF PAYMENT

6-20 REFLECTORIZED SIGNS

6-21 REFLECTORIZED SIGNS

6-21.10 DESCRIPTION. This specification applies to the furnishing of reflective signs constructed on plywood or aluminum substrate or plastic panels to the dimensions in these specifications and as ordered on the sign requisitions. Work shall include the furnishing of all materials, labor, tools, equipment, and supplies to construct; packaging for shipping; obtain carrier; and shipping the signs via Government Bill of Lading or Parcel Post.

6-22 MATERIALS

6-22.10 SUBSTRATE

6-22.11 Aluminum. The aluminum substrate shall be 6061-T6 and otherwise in conformance with ASTM STD B-209. The thickness shall be 0.080 inches for all signs.

6-22.12 Plywood. This shall be High Density Overlay (HDO), two sides, 3/4 inch 7-ply, Douglas fir, exterior plywood, Product Standard PS 1-74, Group 1, with a B grade veneer on both faces. *Mill-oiled concrete form, plywood shall be prohibited.* Surfacing overlay material weight shall be high density 60-60, non-oiled, resin impregnated fiber permanently fused to the base panel under heat and pressure. Panel weight shall be approximately 2.2 pounds per square foot. Overlay color shall be black. Each panel shall be edge-branded HDO B-B G1 EXT PS 1-74. The Contractor shall supply the Contracting Officer (CO) with APA certification that the plywood meets all the above requirements.

6-22.20 REFLECTIVE MATERIALS

6-22.21 Reflective Background, Legend, Border and Symbols. Retroreflective materials shall comply with "Standard Specifications for Construction of Roads and Bridges on Federal Highway Projects", FP-85 and Federal Specification L-S-300C.

The Contractor shall furnish a certification that the materials comply with the requirements of FP-85 and L-S-300.

The Contractor shall indelibly mark each carton of retroreflective materials showing the date received. No more than 12 months shall have elapsed from the date of purchase from the manufacturer to the date of application on the substrate.

6-22.21a Retroreflective Sheeting - Type II. The materials as listed in these specifications shall comply with FP-85, Section 718 and L-S-300C as indicated below:

Colors shall be as specified in specifications for Standard Highway Sign Colors (FHWA, HTO-21).

6-22.21b Retroreflective Sheeting - Type III. The materials as listed in these specifications shall comply with FP-85, Section 718 and L-S-300C as shown below:

Colors shall be as specified in specifications for Standard Highway Sign Colors (FHWA, HTO-21).

6-22.21c Legend, Border, and Symbols. The materials as specified on the requisition shall comply with section 6-22.21.

Type L-1 - screen process, applied, or

Type L-3 - direct applied characters (depending on the type of sign ordered).

6-22.22 Top Edge Treatment Film. Film shall be 3" wide, clear and transparent with a sun-resistant pressure sensitive, non-yellowing adhesive, "Scotchcal"

transparent film #639 or CO-approved equivalent.

6-22.30 TREATMENT OF PLYWOOD SIGN EDGES

6-22.31 Wood Primer. The wood primer shall be as recommended by paint (enamel) manufacturer.

6-22.32 Enamel. Benjamin Moore PENTAFLEX enamel or CO-approved equivalent.

6-23 CONSTRUCTION

6-23.10 WORKMANSHIP. Construction shall be high quality with no visible defects in the finished product. Fabrication shall be in accordance with these specifications, drawings, and detailed diagrams.

6-23.20 WOODWORKING

6-23.21 Board Joining and Cleating. Signboard panels shall be fabricated without cleats or joints.

6-23.22 Machining. Drilling shall be done with high-speed drills. To avoid chipping of the back overlay, a solid backing block shall be used during drilling. High-speed saws shall be used. Saw cuts shall be clean and true. Power saws used for cutting shall have little or no set and have as much lead as possible. Panels shall be fed through saws slowly to avoid damage to the brittle overlay. Table saws shall be set so that the blade extends through the panel not less than ½ inch.

6-23.23 Dimension Tolerances. Dimensions for signboard panels shall be as shown on the detail drawings, with a tolerance of ± ¼ inch.

6-23.24 Edge Sanding and Finishing. All panel edges shall be sanded clean and free of splinters and burrs and shall be smooth to the touch.

6-23.25 Panel Surfaces. These shall be free of warp, checking, slits, open joints, loose knots, and any other defects which interrupt smooth continuity of the panel surface (edges included).

6-23.26 Plywood Storage and Handling. The Contractor shall store the plywood for signs in an enclosed and well-ventilated building. Stored plywood shall not be placed directly on dirt or concrete surfaces. Panels shall be stacked flat. Care shall be used in handling plywood to prevent damage to corners, edges, and faces.

6-23.30 PREPARING PLYWOOD PANELS FOR RETROREFLECTIVE SHEETING

6-23.31 Sanding and Cleaning. Sign face overlay surface of each sign panel shall be sanded with 50 to 60 grit sandpaper on an orbital sander.

Overlay surfaces shall be clean. Edges shall be sanded prior to priming and painting. All panel edges shall be sanded clean. Coregap holes on the edge shall be filled with Mameco International Vulcan 116 polyurethane sealant, Thiokol Pecora Synthacalk GC-9 polysulfide sealant, or a CO-approved glazing compound to produce a flat, smooth surface.

6-23.32 Paint Room Facilities. Primer and enamel shall be applied and dried at an air temperature of not less than 65°F in a well-ventilated, dust-free, enclosed paint room. The paint room shall be separated by full partitions from shop wood-working areas.

6-23.33 Priming and Enamel Application. Sign surfaces shall be clean and free of loose material prior to painting. The sign panel faces shall not be primed or painted. All sign panel edges shall be primed and enameled. One coat of the specified primer (Section 6-22.31) shall be applied to the panel edges prior to application of retroreflective sheeting. One coat of the enamel (Section 6-22.32) shall be applied after application of retroreflective sheeting. Cure time between enamel coats shall be as specified in writing by the manufacturer. Prime plus paint thickness shall provide a minimum of 2 mils ± ½ mil thickness of dry paint film.

6-23.34 Panel Face Cleaning. Successful adhesion of retroreflective sheeting is dependent upon a totally clean and well-scarified panel face to receive the adhesive. Before application of the sheeting, the face shall be free of all foreign matter such as paint or dust.

6-23.40 METALWORKING. The aluminum shall be free of burrs and pits on both sides, including edges and holes, and shall be made ready for application of the sheeting.

6-23.41 Surface Preparation. The aluminum shall be thoroughly cleaned and degreased with solvent and alkaline emulsion cleaner by immersion, spray, or vapor degreasing and dried prior to application of the sheeting coat. The aluminum shall be new and corrosion-free with holes drilled or punched, corners rounded to the radii shown in the drawings, and all edges smoothed prior to application of the sheeting.

6-23.50 RETROREFLECTIVE SHEETING

6-23.51 Colors. These colors shall be as prescribed in the MUTCD or attached requisitions.

6-23.52 Application Methods. The method of application of sheeting, letters, numerals, and symbols shall be precisely as prescribed in writing by the manufacturer of the sheeting. The applicator diaphragm shall have at least two pyrometers centrally attached. The applicator shall also have a cycle control unit approved by the sheeting manufacturer.

Temperature control calibration and accuracy monitoring of the approved cycle control unit shall be required each day that the heat and vacuum applicator is operated. "Teletemp Temperature Recorders" (temperature measuring devices) shall be used. Applicator operating temperature shall be calibrated with the specified temperature measuring device each day of operations, and:

1. Whenever different substrate materials are being used.
2. Whenever a diaphragm, light-bulb, cycle-control unit, or thermocouple is replaced.
3. Whenever different types or different colors of reflective sheeting are used.

The sheeting shall be precut to size or trimmed to the edges. The entire face of the panel shall be covered with one unspliced sheet.

Flexible sheeting shall be positioned to provide $\frac{1}{8}$ inch to $\frac{5}{32}$ inch overlap onto all panel edges after trimming. Use of two reflective faces (dual face) on one plywood panel is prohibited.

6-23.60 RETROREFLECTIVE LEGEND

6-23.61 Legend Type. The legend shall be applied by using die-cut, adhesive-backed letters, numerals, and symbols.

6-23.62 Use of Positionable Legend. If Class 1 adhesive-backed legend is used, characters shall be firmly squeegeed, after proper alignment, to ensure complete adhesion. No loose or curled edges and no bubbles or blisters will be permitted.

6-23.63 Legend Series. All regulatory, warning, construction, and maintenance signs shall conform to the MUTCD. All directional guide/informational signs shall use NPS Modified Clarendon letters and numerals unless otherwise specified.

6-23.64 Legend Spacing and Layout.

6-23.64a Spacing and Layout for Standard Traffic Signs. Spacing and Layout for all standard regulatory, warning, construction, and maintenance signs shall conform to the "Standard Highway Signs Book".

6-23.64b *Spacing and Layout for Modified Clarendon Lettering.* Spacing and Layout for all signs constructed for NPS Modified Clarendon alphabet shall conform with Chapter 5 of the NPS Sign Manual.

6-23.65 **Tolerance for Horizontal Alignment.** Letters, numerals, and symbols shall be horizontally aligned to a tolerance of $\pm \frac{1}{16}$ inch. Tests of each sign-board shall be as follows:

Place a metal straightedge along the bottom of a series of letters forming each line of the sign. In each line, letters shall not vary more than $\frac{1}{16}$ inch from that line.

6-23.66 **Tolerance for Vertical Alignment.** Letters, numerals, and symbols shall be vertically aligned to a tolerance of $\pm \frac{1}{16}$ inch. The following tests shall be performed on each letter in each line:

Place a metal straightedge along the bottom of a series of letters forming each line of the sign. Place a square along the straightedge and test the trueness of vertical faces of individual letters. Letters shall be normal to the square within $\frac{1}{16}$ inch.

6-23.70 **NONREFLECTIVE LEGEND**

6-23.71 **Legend Series.** All letters, numerals, and symbols shall be as prescribed in Section 6-23.64.

6-23.72 **Tolerance for Horizontal Alignment.** As described in Section 6-23.65.

6-23.73 **Tolerance for Vertical Alignment.** As described in Section 6-23.66.

6-23.74 **Silkscreening.** Letter styles shall conform to specifications for die-cut legend in Section 6-23.64.

Screen processing, when used, shall be of careful workmanship with neat, clean lines and corners, performed strictly as prescribed by the manufacturer of the transparent colors.

6-23.80 **TOP EDGE TREATMENT.** After all legend has been applied, the sign panel shall be recycled in the heat and vacuum applicator for two minutes at a temperature of approximately 190 °F under 21 inches of vacuum. When the sign panels have cooled, the top edge of each sign shall be covered with a clear, three-inch-wide transparent film ("Scotchcal" #639 film or a CO-approved equivalent) with a sun-resistant, pressure-sensitive adhesive that does not turn yellow under exposure to ultraviolet radiation. Film shall be applied in lengths not to exceed 24 inches.

Where more than one piece is required, film shall be applied from each corner of the top edge toward the center of the top edge. End overlap of two inches or more shall be required where one film piece joins another.

6-24 **SURFACES**

6-24.10 **SILKSCREENING.** The screening of inks shall be as herein defined. All screen work shall be of high quality. Images shall be clean, crisp, and clear. The screen-inks shall be drawn over the screen with a firm, even pressure. As needed, three to five minutes shall be allowed for the ink to flow out so that it has a smooth surface.

6-25 **DECALS AND MARKINGS**

6-25.10 **ANTIVANDALISM DECALS.** The decal shall be installed on the back bottom left corner of the sign. Decals will be supplied by the National Park Service.

6-25.20 **MAKER'S MARK.** Each sign shall be permanently marked on the lower right corner of the back side with the month and year of manufacture and a suitable

maker's mark. The maker's mark shall be applied prior to painting in event sign back is to be painted.

6-25.30 INSTALLATION DATE MARK. Each sign shall be permanently marked near the lower right corner of the back side with the month and year of installation, by the sign installer.

6-26 METHOD OF MEASUREMENT. Where signs shown in the Schedule of Items list the unit as *square foot*, signs shall be measured for the actual square footage of surface area on each reflectorized face of the sign to the nearest $\frac{1}{2}$ square foot, completed and accepted.

The Method of Measurement for other signs where the unit is listed as *each* shall be the actual number of signs, completed, and accepted.

6-27 BASIS OF PAYMENT. The quantities, determined as provided in Section 6-26, shall be paid for at the contract price per unit of measurement for each of the particular pay items listed.

Price and payment shall be full compensation for furnishing all materials, labor, equipment, tools, and incidentals needed to complete the work prescribed in the specifications.

6-30 ROUTED WOOD SIGNS

CONTENTS

6-31	ROUTED SOLID WOOD SIGNS
6-31.10	DESCRIPTION
6-31.20	MATERIALS
6-31.21	Dimensional Lumber
6-31.22	Adhesive
6-31.23	Paints
6-31.24	Stain and Sealer
6-31.24a	<i>Gray Stain</i>
6-31.24b	<i>"Redwood" Stain</i>
6-31.24c	<i>Dark Brown Stain</i>
6-31.24d	<i>Bleaching Oil</i>
6-31.25	Metal Rod
6-31.26	Wood Dowel
6-31.27	Plywood Backing (Optional)
6-31.30	CONSTRUCTION
6-31.31	Dimensional Lumber
6-31.32	Doweling (Optional)
6-31.33	Preparation of Surface Joints
6-31.34	Temperatures
6-31.35	Glue Application
6-31.36	Clamping and Curing
6-31.37	Machining
6-31.38	Edge Rounding
6-31.39	Plywood Backing (Optional)
6-31.40	LEGEND: LAYOUT AND TOLERANCES
6-31.41	Graphic Layout
6-31.42	Horizontal Alignment

6-31.43	Vertical Alignment
6-31.44	Routing
6-31.50	FINISHING
6-31.51	Sanding
6-31.52	Cleaning
6-31.53	Maker's Mark
6-31.54	Painting
6-31.55	Staining
6-31.56	Natural Weathered (Optional)
6-31.56a	<i>Wire Brushing</i>
6-31.56b	<i>Bleaching Oil</i>
6-31.60	METHOD OF MEASUREMENT
6-31.70	BASIS OF PAYMENT
6-32	ROUTED HDO PLYWOOD SIGNS
6-32.10	DESCRIPTION
6-32.20	MATERIALS
6-32.21	HDO Plywood
6-32.22	Paints
6-32.30	CONSTRUCTION
6-32.31	Storage and Handling
6-32.32	Board Joining
6-32.33	Machining
6-32.34	Coregap Filling
6-32.35	Edge Rounding
6-32.40	LEGEND: LAYOUT AND TOLERANCES
6-32.41	Graphic Layout
6-32.42	Horizontal Alignment
6-32.43	Vertical Alignment

6-32.44	Routing
6-32.50	FINISHING
6-32.51	Sanding
6-32.52	Maker's Mark
6-32.53	Painting
6-32.60	METHOD OF MEASUREMENT
6-32.70	BASIS OF PAYMENT
6-33	ROUTED WOOD FOAM CORE SIGNS
6-33.10	DESCRIPTION
6-33.20	MATERIALS
6-33.21	Dimensional Lumber
6-33.22	Foam Core
6-33.23	Adhesive
6-33.24	Stain and Sealer/Marine Oil
6-33.24a	<i>Gray Stain</i>
6-33.24b	<i>"Redwood" Stain</i>
6-33.24c	<i>Dark Brown Stain</i>
6-33.24d	<i>Sealer/Marine Oil Application</i>
6-33.30	CONSTRUCTION
6-33.31	Preparation of Front and Back Panels
6-33.31a	<i>Dimensional Lumber</i>
6-33.31b	<i>Preparation of Surface Joints</i>
6-33.31c	<i>Temperatures</i>
6-33.32	Preparation of Core
6-33.32a	<i>Edge Core</i>
6-33.32b	<i>Foam Core Preparation</i>
6-33.33	Assembly
6-33.33a	<i>Glue Application</i>
6-33.33b	<i>Final Clamping and Curing</i>

6-33.34	Machining
6-33.35	Edge Rounding
6-33.40	LEGEND: LAYOUT AND TOLERANCES
6-33.41	Graphic Layout
6-33.42	Horizontal Alignment
6-33.43	Vertical Alignment
6-33.44	Routing
6-33.50	FINISHING
6-33.51	Sanding
6-33.52	Cleaning
6-33.53	Maker's Mark
6-33.54	Staining
6-33.55	Sealer/Marine Oil Application
6-33.60	METHOD OF MEASUREMENT
6-33.70	BASIS OF PAYMENT

6-30 ROUTED WOOD SIGNS

6-31 ROUTED SOLID WOOD SIGNS

6-31.10 DESCRIPTION. This specification applies to the furnishing of routed solid wood signs as ordered on the attached requisition. This work shall include the furnishing of all materials, labor, tools, equipment, and supplies to construct, package, and ship the signs via Government Bill of Lading or Parcel Post.

6-31.20 MATERIALS

6-31.21 Dimensional Lumber. Dimensional lumber should be kiln-dried, vertical grain with maximum moisture content of 19 percent. Nominal thickness and type of lumber shall be specified by Contracting Officer (CO). Recommended types include:

- (1) Clear vertical grain heart redwood with maximum moisture content of 12%,
- (2) Western red cedar, B or better grade, selected for vertical grain, with maximum moisture content of 19%,
- (3) Red or White oak, rough sawn, air dried, hardwood lumber grade No. 1 common or better (used for trail signs only).

6-31.22 Adhesive. Adhesive shall be (1) a phenolic resin glue waterproof to 180°F., Bordon Chemical "Wonderbond" W-926A; (2) an all solids (without extender or thinner) epoxy adhesive, Chem-Tech T-88; (3) an urea-formaldehyde thermosetting resin glue conforming to Federal Specifications MMM-A-188C (e.g. Weldwood Plastic Resin) or CO-approved equivalent.

6-31.23 Paints. Primer and finish coats for sign backs, faces, edges, and lettering shall be Benjamin Moore's ready-mixed, exterior type, PENTAFLEX, or CO-approved equivalent. Color for backs, faces and edges of signs shall be Federal Standard 595a Color No. 20059(brown). Color for lettering shall be Federal Standard 595a Color No. 17875(white). Thinner and solvent shall be as recommended by the manufacturer.

6-31.24 Stain and Sealer.

6-31.24a Gray Stain. Shall be composed of the following mixture: Three (3) parts Olympic Semitransparent Stain No. 908 or CO-approved equivalent, and one (1) part of Cabot's Colorless Creosote No. 230 or CO-approved equivalent.

6-31.24b "Redwood" Stain. Shall be composed of the following mixture: Three (3) parts Olympic Semitransparent Stain No. 717 or CO-approved equivalent and one (1) part of Cabot's Colorless Creosote No. 230 or CO-approved equivalent.

6-31.24c Dark Brown Stain. Shall be composed of the following mixture: Three (3) parts Olympic Semitransparent Stain No. 725 or CO-approved equivalent and one (1) part of Cabot's Colorless Creosote No. 230 or CO-approved equivalent.

6-31.24d Bleaching Oil. Shall be Cabot's Bleaching oil or CO-approved equivalent.

6-31.25 Metal Rod. Shall be steel, all thread rod, ½ inch diameter, minimum 36 inches in length.

6-31.26 Wood Dowel. Shall be ¾ inch diameter maple wood dowel maximum 36 inches in length.

6-31.27 Plywood Backing (Optional). Shall be ¾ inch exterior-grade plywood.

6-31.30 CONSTRUCTION. Construction shall be of high quality with no internal or visible defects in the finished product. Dimensions and corner radii shall be as specified on attached drawings, with an allowable tolerance of ± ¼ inch. When the

first order is placed, the Contractor shall complete a sample signboard and submit it to the CO for approval before proceeding with further construction.

6-31.31 Dimensional Lumber. Sign panels shall be fabricated from boards not more than eight inches nor less than four inches in width. End grain on each board shall be reversed to minimize checking and sign warpage. Joined boards shall match on all surfaces within a tolerance of $\frac{1}{32}$ inch. Vertical joints shall not be used.

6-31.32 Doweling (Optional). When used, holes for doweling shall be machine drilled through boards 16 inches on center starting three inches in from edge. Holes shall be oversized $\frac{1}{16}$ inch. When vertical dimension is 36 inches or less a wood dowel shall be used.

When vertical dimension is greater than 36 inches, a metal dowel shall be used and counter sunk one inch and plugged.

6-31.33 Preparation of Surface Joints. Wood surfaces to be glued shall be smooth and true, free from machine-jointing marks and chipped or loosened grain. Glueline surfaces shall be free from dust, grease, and other foreign matter.

6-31.34 Temperatures. Boards to be joined by gluing shall be stacked on stickers at air temperatures between 70°F and 90°F for not less than 24 hours prior to gluing. During the glue application and curing processes, air temperatures shall be not less than 70°F nor more than 90°F.

6-31.35 Glue Application. Glue shall be applied in accordance with manufacturer's recommendations to the entire surface of each joint face. Maximum allowable time between start of glue application and final setting of clamps on the sign panel shall be in accordance with manufacturer's recommendations.

6-31.36 Clamping and Curing. Clamping pressure and curing times shall conform to manufacturer's recommendations. Allow to cure 48 hours prior to any machining.

6-31.37 Machining. All cuts and drilling shall be accurate and clean. Table saws shall be set so that the blade extends through the panel not less than $\frac{1}{2}$ inch. Drilling should be done with high-speed drills to avoid chipping.

6-31.38 Edge Rounding. Following the cutting of sign panel to size, all face and back edges shall be rounded to a radius to $\frac{1}{8}$ inch.

6-31.39 Plywood Backing (Optional). Following gluing and curing of dimensional lumber, the plywood shall be cut to match the sign backs and glued and clamped in place. Clamping pressure and curing times shall conform to manufacturer's recommendations.

6-31.40 LEGEND: LAYOUT AND TOLERANCES

6-31.41 Graphic Layout. Graphic layout shall be as shown on attached drawings. Artwork is to be accurately reproduced, enlarged in size to meet dimensions shown on scaled drawings. Allowable reproduction tolerance is $\pm \frac{1}{2}\%$. An accurate grid shall be used to insure layout is level and plumb.

6-31.42 Horizontal Alignment. Letters, numerals, and symbols shall be horizontally aligned to a tolerance of $\pm \frac{1}{16}$ inch. Test method for horizontal alignment is as follows:

Place a metal straightedge along the bottom of a series of letters forming one line on the sign. In each line, letters shall not vary more than $\frac{1}{16}$ inch from that line.

6-31.43 Vertical Alignment. Letters, numerals, and symbols shall be vertically aligned to a tolerance of $\pm \frac{1}{16}$ inch. Test method for alignment is as follows:

Place a metal straightedge along the bottom of a series of letters forming one line of the sign. Place a square along the straightedge; individual letters shall be normal to the square with a tolerance of $\frac{1}{16}$ inch.

6-31.44 Routing. Routed letters and graphics on signs shall be the size specified on supplementary drawings. Letters shall be NPS Modified Clarendon letter style or as noted on contract drawings. All letters and graphics shall be machine-routed with a v-grooved or oval-sided flat-bottom bit. One inch letters and smaller shall be routed $\frac{1}{8}$ inch to $\frac{3}{16}$ inch depth, letters 1 $\frac{1}{2}$ inches and larger shall be routed $\frac{1}{4}$ inch to $\frac{3}{8}$ inch depth or as specified on drawings. Routing depth shall be consistent for each letter size on any one sign.

6-31.50 FINISHING

6-31.51 Sanding. All burrs on edges or routed channels shall be removed by sanding with the grain of the wood. Final sanding shall be with an 80 or 100 medium-grit sandpaper and shall leave the sign face, back, and edges smooth without gouge marks.

6-31.52 Cleaning. All sign surfaces shall be wiped, airblown, or vacuumed clean before painting or staining to insure removal of sawdust.

6-31.53 Maker's Mark. Sign manufacturer shall mark the lower right corner of the back of each sign, identifying manufacturer and manufacturing date.

6-31.54 Painting. All painting shall be accomplished in a well-ventilated, dust-free paint room separated by full partitions from shop woodworking areas. Paint shall be applied and allowed to cure at air temperatures specified by the manufacturer. Paint shall be thoroughly mixed prior to each use and at frequent intervals during use to insure against pigment separation. Paint shall be applied to all surfaces in a minimum of four coats to provide a dry paint film thickness of 4 mils \pm 0.5 mil. Color schedule shall be as specified on supplementary drawings.

Two coats shall be applied by brush or spray to provide continuous primer across all sign surfaces. Finish paint in routed areas of sign face shall be applied by brush, spray or puddling, providing coverage of entire vertical portion of routed areas. Finish paint on sign face, back, and edges shall be applied by spray or roller. A short nap roller is recommended to prevent paint from dripping into routed areas. Drying time between coats shall be specified by the paint manufacturer.

Signs which show alligatoring, nicks or slopping of paint in and around routed areas shall be rejected.

6-31.55 Staining (Optional). All surfaces shall receive a minimum two coats of stain. Color schedule shall be as specified on supplementary drawings. Stain shall be liberally and uniformly applied to the edges, back, and face of the sign by brush or roller, and to routed surfaces by brushing. Stain shall be thoroughly mixed prior to each use and at frequent intervals during use to insure against pigment separation. All stain is to be thoroughly brushed in. Excess stain remaining shall then be removed by wiping.

6-31.56 Natural Weathered (Optional).

6-31.56a Wire Brushing. Face of panel shall be mechanically brushed in the direction of the wood grain to remove the soft wood grains to a nominal depth of $\pm \frac{1}{8}$ inch.

6-31.56b Bleaching Oil. Oil shall be applied and allowed to cure according to manufacturer's specifications.

6-31.60 METHOD OF MEASUREMENT. Where the Schedule of Items lists the unit as *square foot*, measurement shall be made for the actual square footage of surface area on the face of each sign, measured to the nearest $\frac{1}{2}$ square foot, completed and accepted. The method of measurement for other signs where the unit is listed as *each* shall be the actual number of signs completed and accepted.

6-31.70 BASIS OF PAYMENT. The quantities shall be paid for at the contract price per unit of measurement for each of the particular pay items listed, which pay-

ment shall be full compensation for furnishing all materials, labor, equipment, tools, and incidentals needed to complete the work prescribed in the specifications.

6-32 ROUTED HDO PLYWOOD SIGNS

6-32.10 DESCRIPTION. This specification applies to the furnishing of routed HDO plywood signs as ordered on the attached requisition. This work shall include the furnishing of all materials, labor, tools, equipment, and supplies to construct, package, and ship the signs via Government Bill of Lading or Parcel Post.

6-32.20 MATERIALS

6-32.21 HDO Plywood. Plywood shall be $\frac{3}{4}$ inch thick, 7-ply, marine A-A face, all Douglas Fir grade B or better core, and otherwise conform to U.S. Product Standard PS1-74. Each plywood sheet shall be branded as follows:

HDO-AA-G1 Marine-APA-PS1-74

Sign panels which are warped or show signs of checking, splits, open joints, loose knots or other surface defects shall be rejected.

6-32.22 Paints. Primer and finish coats shall be Benjamin Moore's ready-mixed, exterior type, PENTAFLEX or Contracting Officer (CO)-approved equivalent. Color for backs, faces, and edges of signs shall be Federal Standard 595a Color No. 20059(brown). Color for lettering shall be Federal Standard 595a Color No. 17875(white). Thinner and solvent shall be as recommended by the paint manufacturer.

6-32.30 CONSTRUCTION. Construction shall be of high quality with no internal or visible defects in the finished product. Dimensions and corner of radii shall be as specified on attached drawings, with an allowable tolerance of $\pm \frac{1}{4}$ ". When the first order is placed, the Contractor shall complete a sample signboard and submit it to the CO for approval before proceeding with further construction.

6-32.31 Storage and Handling. Panels shall be stacked flat in an enclosed and well-ventilated building. Stored plywood shall not be placed directly on dirt or concrete surfaces. Care shall be used in handling plywood to prevent damage to corners, edges, and faces. Damaged plywood panels shall be rejected.

6-32.32 Board Joining. No board joining shall be allowed for routed HDO plywood signs.

6-32.33 Machining. All cuts and drilling shall be accurate and clean. Panels shall be fed through saws slowly to avoid damage to the overlay. Table saws shall be set so that the blade extends through the panel not less than $\frac{1}{2}$ inch. Drilling should be done with high speed drills to avoid chipping of the back of sign.

6-32.34 Coregap Filling. Edge coregap holes shall be filled with Mameco International Vulcan 116 polyurethane sealant, Thiokol Pecora Synthacalk GC-9 polysulfide sealant, or CO-approved equivalent to produce a flat, gap-free surface. Edge filler shall be cured in accordance with manufacturer's recommendations, and then sanded smooth.

6-32.35 Edge Rounding. All face and back edges shall be rounded to a radius of $\frac{1}{16}$ inch.

6-32.40 LEGEND: LAYOUT AND TOLERANCES

6-32.41 Graphic Layout. Graphic layout shall be as shown on attached drawings. Artwork is to be accurately reproduced, enlarged in size to meet dimensions shown on scaled drawings. Allowable reproduction tolerance is $\pm \frac{1}{2}$ %. An accurate grid shall be used to insure layout is level and plumb.

6-32.42 Horizontal Alignment. Letters, numerals, and symbols shall be horizontally aligned to a tolerance of $\pm \frac{1}{16}$ inch. Test method for horizontal alignment is as follows:

Place a metal straightedge along the bottom of a series of letters forming one line on the sign. In each line, letters shall not vary more than $\frac{1}{16}$ inch from that line.

6-32.43 Vertical Alignment. Letters, numerals, and symbols shall be vertically aligned to a tolerance of $\pm \frac{1}{16}$ inch. Test method for alignment is as follows:

Place a metal straightedge along the bottom of a series of letters forming one line of the sign. Place a square along the straightedge; individual letters shall be normal to the square with a tolerance of $\frac{1}{16}$ inch.

6-32.44 Routing. Routed letters and graphics on signs shall be the size specified on the supplementary drawings. Letters shall be NPS Modified Clarendon style or as noted on drawings. All letters and graphics shall be machine-routed with an oval-sided flat-bottom bit. Routing depth shall be $\frac{1}{16}$ inch.

6-32.50 FINISHING

6-32.51 Sanding. Prior to painting, sign face, back, and panel edges shall be sanded with 50 to 60 grit sandpaper. Sanding shall leave surfaces smooth without gouge marks.

6-32.52 Maker's Mark. Sign manufacturer shall mark the lower right corner of the back of each sign, identifying the manufacturer and manufacturing date.

6-32.53 Painting. All painting shall be accomplished in a well-ventilated, dust-free paint room separated by full partitions from shop woodworking areas. Paint shall be applied and allowed to cure at air temperatures specified by the paint manufacturer. Paint shall be thoroughly mixed prior to each use and at frequent intervals during use to insure against pigment separation. Paint shall be applied to all surfaces in a minimum of four coats to provide a dry paint film thickness of 4 mils $\pm \frac{1}{2}$ mil. Color schedule shall be as specified on supplementary drawings.

Two coats shall be applied by brush or spray to provide continuous primer across all sign surfaces. Finish paint in routed areas of sign face shall be applied by brush, spray or puddling, providing coverage of entire vertical portion of routed areas. Finish paint on sign face, back and edges shall be applied by spray or roller. A short nap roller is recommended to prevent paint from dripping into routed areas. Drying time between coats shall be as specified by the paint manufacturer.

Signs which show alligating, nicks, or stopping of paint in and around routed areas shall be rejected.

6-32.60 METHOD OF MEASUREMENT. Where the Schedule of Items lists the unit as *square foot*, measurement shall be made for the actual square footage of surface area on the face of each sign, measured to the nearest $\frac{1}{2}$ square foot, completed and accepted. The method of measurement for other signs where the unit is listed as *each* shall be the actual number of signs completed and accepted.

6-32.70 BASIS OF PAYMENT. The quantities shall be paid for at the contract price per unit of measurement for each of the particular pay items listed, which payment shall be full compensation for furnishing all materials, labor, equipment, tools, and the incidentals needed to complete the work prescribed in the specifications.

6-33 ROUTED WOOD FOAM CORE SIGNS

6-33.10 DESCRIPTION. This specification applies to the furnishing of wood signs with a rigid polyurethane foam core construction signs as ordered on the attached requisition. Work shall include the furnishing of all materials, labor, tools, equipment, and supplies to construct, package, and ship the signs via Government Bill of Lading or Parcel Post.

6-33.20 MATERIALS

6-33.21 Dimensional Lumber. Dimensional lumber for face panels, back panels, wood blocking (if any), and edge closeout shall be one of the following, as specified on the attached requisition:

- (1) Clear vertical grain heart redwood with maximum moisture content of 12%.
- (2) Western red cedar, B or better grade, selected for vertical grain, with maximum moisture content of 19%.

Nominal thickness of lumber for use in face and back panels shall be 1 inch. Edge core closeout material shall be 1 1/2" thick, unless otherwise specified on the attached requisition. The grain pattern in every piece of wood shall be aligned with that of the surface panels.

6-33.22 Foam Core. The core shall be 1 1/2" thick high density rigid polyurethane foam, Last-A-Foam FR-3704 (General Plastics Mfg. Co., Tacoma, Washington) or Contracting Officer (CO)-approved equivalent.

6-33.23 Adhesive. Adhesive (glue) shall be an urea-formaldehyde thermosetting resin adhesive conforming to Federal Specifications MMM-A-118C (e.g. Weldwood Plastic Resin) or CO-approved equivalent.

6-33.24 Stain and Sealer/Marine Oil

6-33.24a Gray Stain. Shall be composed of the following mixture: Three (3) parts Olympic Semitransparent Stain No. 908 or CO-approved equivalent, and one (1) part of Cabot's Colorless Creosote No. 230 or CO-approved equivalent.

6-33.24b "Redwood" Stain. Shall be composed of the following mixture: Three (3) parts Olympic Semitransparent Stain No. 717 or CO-approved equivalent, and one (1) part of Cabot's Colorless Creosote No. 230 or CO-approved equivalent.

6-33.24c Dark Brown Stain. Shall be composed of the following mixture: Three (3) parts Olympic Semitransparent Stain No. 725 or CO-approved equivalent, and one (1) part of Cabot's Colorless Creosote No. 230 or CO-approved equivalent.

6-33.24d Sealer/Marine Oil Application. Shall consist of Deks Olje #1 (matte finish) or Deks Olje #2 (gloss finish) or CO-approved equivalent.

6-33.30 CONSTRUCTION. Construction shall be of high quality with no internal or visible defects in the finished product. Dimensions and corner radii shall be as specified on attached drawings, with an allowable tolerance of $\pm 1/4$ inch. When the first order is placed, the Contractor shall complete a sample signboard and submit it to the CO for approval before proceeding with further construction.

6-33.31 Preparation of Front and Back Panels.

6-33.31a Dimensional Lumber. Sign panels made of dimensional lumber shall be fabricated from boards not more than eight inches nor less than four inches in

width. Boards shall be butt jointed, reversing end grain on each board to minimize checking and sign warpage. Joining boards shall match on all surfaces. Vertical joints shall not be used.

6-33.31b Preparation of Surface Joints. Wood surfaces to be glued shall be smooth and true, free from machine-jointing marks, chipped or loosened grain, dust, grease, and other foreign matter.

6-33.31c Temperatures. Boards to be joined by gluing shall be stacked on stickers at air temperatures between 70°F and 90°F for not less than 24 hours prior to gluing. During the glue application and curing processes, air temperatures shall be not less than 70°F nor more than 90°F.

6-33.32 Preparation of Core

6-33.32a Edge Core. Edge core lumber shall be cut to fit periphery of the rear panel.

6-33.32b Foam Core Preparation. Foam core shall be cut to snug fit in cavity formed by edge core with no voids. At each point indicated in supplemental drawings, foam shall be cut to accommodate wood blocks, to fit exactly with no voids.

6-33.33 Assembly. Fabrication is to resemble the construction of a shallow box formed by the glued up back panel, to which is glued the edge closeout stock. Rigid polyurethane foam sheet stock is cut to fit closely into the cavity formed by edge closeouts, and glued all around and to back panel. Any wood blocking shown on drawings shall be inserted into foam core previously cut for that purpose, and shall be glued all around and to back panel. The box is then closed by glueing face panel to the foam core, any wood blocks and edge closeouts (see figure #1). The procedure is to be one continuous glueing operation, conducted within the allowable working time of the specified adhesive.

6-33.33a Glue Application. Glue shall be applied according to glue manufacturer's recommendations to the entire surface of each glue joint. Maximum allowable time between start of glue application and final setting of clamps on the sign panel shall be in accordance with glue manufacturer's recommendations.

6-33.33b Final Clamping and Curing. Clamping pressure and curing times shall be in accordance with glue manufacturer's recommendations.

6-33.34 Machining. All cuts and drilling shall be accurate and clean. Table saws shall be set so that the blade extends through the panel not less than ½ inch. Drilling should be done with high-speed drills to avoid chipping.

6-33.35 Edge Rounding. Following the fabrication of the panel, all edges on the sign shall be rounded to a radius of ¼ inch.

6-33.40 LEGEND: LAYOUT AND TOLERANCES

6-33.41 Graphic Layout. Graphic layout shall be as shown on attached drawings. Artwork is to be accurately reproduced, enlarged in size to meet dimensions shown on scaled drawings. Allowable reproduction tolerance is $\pm \frac{1}{2}\%$. An accurate grid shall be used to insure layout is level and plumb.

6-33.42 Horizontal Alignment. Letters, numerals, and symbols shall be horizontally aligned to a tolerance of $\pm \frac{1}{16}$ inch. Test method for horizontal alignment is as follows:

Place a metal straightedge along the bottom of a series of letters forming one line on the sign. No letter shall vary more than $\frac{1}{16}$ inch from that line.

6-33.43 Vertical Alignment. Letters, numerals, and symbols shall be vertically aligned to a tolerance of $\pm \frac{1}{16}$ inch. Test method for alignment is as follows:

Place a metal straightedge along the bottom of a series of letters forming one line of the sign. Place a square along the straightedge; individual letters shall be normal to the square with a tolerance of $\frac{1}{16}$ inch.

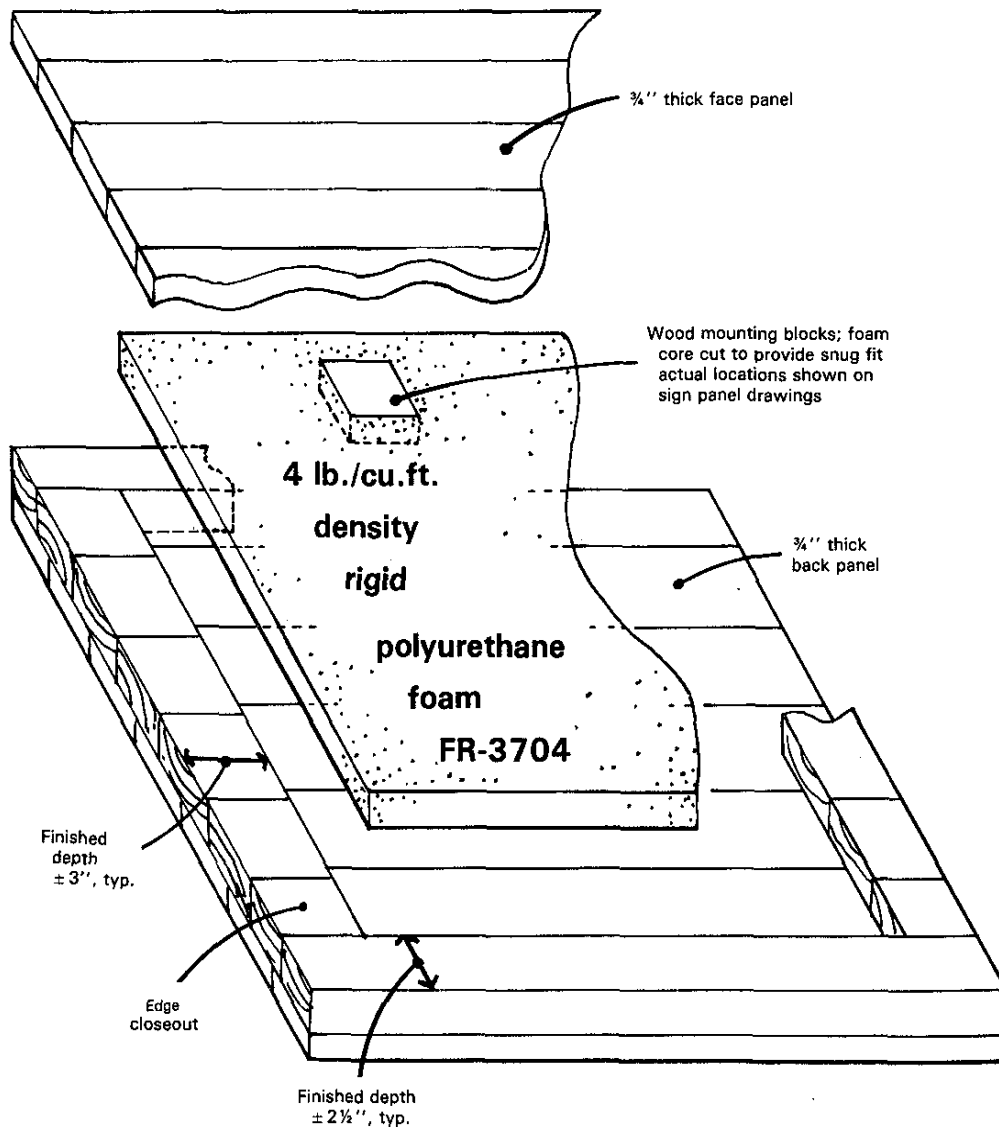

Figure 1. Typical rigid polyurethane foam core sign panel (exploded view)

6-33.44 Routing. Routed letters and graphics on signs shall be the size specified on the supplementary drawings. Letters shall be NPS Modified Clarendon style or as shown on attached drawings. All letters and graphics shall be machine routed with a V-grooved or oval-sided flat-bottom bit. Routing depth shall be $\frac{1}{4}'' \pm \frac{1}{16}''$ and shall be consistent for all routing on any one sign.

6-33.50 FINISHING

6-33.51 Sanding. All burrs on edges of routed channels shall be removed by sanding with the grain of the wood. Final sanding shall be with an 80 or 100 medium-grit sandpaper and shall leave the sign face, back, and edges smooth without gouge marks.

6-33.52 Cleaning. All sign surfaces shall be wiped, airblown, or vacuumed clean before staining or oiling to insure removal of sawdust.

6-33.53 Maker's Mark. Sign manufacturer shall mark the lower right corner of the back of each sign, identifying the manufacturer and manufacturing date.

6-33.54 Staining. All surfaces shall receive at least two coats of stain, allowing a minimum 24 hours drying time between applications. Color schedule shall be as specified on supplementary drawings. Stain shall be liberally and uniformly applied to the edges, back, and face of the sign by brush or roller, and to routed surfaces by brushing. Stain shall be thoroughly mixed prior to each use and at frequent intervals during use to insure against pigment separation. All stain is to be thoroughly brushed in. Excess stain remaining shall then be removed by wiping. Signs shall be dried face-up a minimum of 24 hours before sealing and packaging.

6-33.55 Sealer/Marine Oil Application. Oil finish shall be applied in a dust-free area, and according to the recommendations of the product manufacturer. Matte finish or glossy finish shall be specified on the supplementary drawings or on the attached requisition.

6-33.60 METHOD OF MEASUREMENT. Where the Schedule of Items lists the unit as *square foot*, measurement shall be made for the actual square footage of surface area on the face of each sign, measured to the nearest $\frac{1}{2}$ square foot, completed and accepted. The method of measurement for other signs where the unit is listed as *each* shall be the actual number of signs completed and accepted.

6-33.70 BASIS OF PAYMENT. The quantities shall be paid for at the contract price per unit of measurement for each of the particular pay items listed, which payment shall be full compensation for furnishing all materials, labor, equipment, tools, and incidentals needed to complete the work prescribed in the specifications.

6-40 NPS ARROWHEAD EMBLEMS

CONTENTS

6-41	ROUTED WOOD EMBLEMS
6-41.10	DESCRIPTION
6-41.20	MATERIALS
6-41.21	Dimensional Lumber
6-41.22	Plywood Backing(Optional)
6-41.23	Paint
6-41.24	Adhesive
6-41.30	CONSTRUCTION
6-41.31	Preparation of Surface Joints
6-41.32	Temperature
6-41.33	Glue Application
6-41.34	Clamping and Curing
6-41.35	Coregap Filling
6-41.36	Chamfered Edges
6-41.40	GRAPHIC LAYOUT
6-41.41	Routing
6-41.50	FINISHING
6-41.51	Sanding
6-41.52	Cleaning
6-41.53	Painting
6-41.60	METHOD OF MEASUREMENT
6-41.70	BASIS OF PAYMENT
6-42	SILKSCREENED EMBLEM DECALS
6-42.10	DESCRIPTION
6-42.20	MATERIALS

6-42.21	Substrate
6-42.21a	<i>Aluminum</i>
6-42.21b	<i>Plywood</i>
6-42.22	Background Sheeting
6-42.22a	<i>Reflective Emblem Color</i>
6-42.22b	<i>Nonreflective Emblem Color</i>
6-42.23	Treatment of Plywood Sign Edges
6-42.23a	<i>Wood Primer</i>
6-42.23b	<i>Enamel</i>
6-42.30	CONSTRUCTION
6-42.31	Workmanship
6-42.32	Preparing Plywood Panels for Sheeting
6-42.32a	<i>Sanding and Cleaning</i>
6-42.32b	<i>Paint Room Facilities</i>
6-42.32c	<i>Priming and Enamel Application</i>
6-42.32d	<i>Panel Face Cleaning</i>
6-42.33	Metalworking
6-42.33a	<i>Surface Preparation</i>
6-42.34	Application Methods
6-42.35	Silkscreening
6-42.40	LAYOUT
6-42.50	FINISHING (Not Applicable)
6-42.60	METHOD OF MEASUREMENT
6-42.70	BASIS OF PAYMENT

6-40 NPS ARROWHEAD EMBLEMS

6-41 ROUTED WOOD EMBLEMS

6-41.10 DESCRIPTION. This specification applies to the furnishing of routed wood emblems as ordered on the attached requisition. This work shall include the furnishing of all materials, labor, tools, equipment, and supplies to construct, package, and ship the emblem via Government Bill of Lading or Parcel Post.

6-41.20 MATERIALS

6-41.21 Dimensional Lumber. Dimensional lumber shall be kiln-dried, vertical grain with maximum moisture content of 19 percent. Redwood, cedar, cypress or other durable stock shall be used. Recommended lumber includes:

- (1) Clear vertical grain heart redwood with maximum moisture content of 12%,
- (2) Western red cedar, B or better grade, selected for vertical grain, with maximum moisture content of 19%,
- (3) Bald cypress, incense cedar or other wood as specified by the Contracting Officer.

Nominal thickness is to be two inches for sizes up to 21 ½" x 27". Emblems 14 ¼" x 18" and larger shall be backed with ¾" AC exterior grade plywood. Nominal thickness for emblems 30" x 40" and larger shall be 3".

6-41.22 Plywood Backing(Optional). Plywood shall be ¾" thick, AC exterior grade.

6-41.23 Paint. Primer and finish coat for emblem backs, faces, edges graphics, and lettering shall be a catalized automotive enamel or Contracting Officer (CO)-approved equivalent. Color for background, edges and back shall be cocoa brown Federal Standard (F.S.) 595a Color No. 20233 (semi-gloss). Color for trees and buffalo shall be dark blue green, F.S. 595a Color No. 34058 (flat). Color for mountain tops and lake shall be cream, F.S. 595a Color No. 23690 (semigloss). Color for lettering shall be white, F.S. 595a Color No. 17875 (glossy). Specified color numbers are those found in Federal Standard 595a, dated January 2, 1968, Change Notice 1, January 2, 1968. Thinner and solvent shall be as recommended by the paint manufacturer. For improved durability, official colors may be specified as all glossy finish.

6-41.24 Adhesive. Adhesive shall be (1) a phenolic resin glue waterproof to 180 °F, Borden Chemical "Wonderbond" W-926A; (2) an all solids (without extender or thinner) epoxy adhesive, Chem Tech T-88; (3) an urea-formaldehyde thermosetting resin glue conforming to Federal Specification MMM-A-188C (e.g. Weldwood Plastic Resin) or CO-approved equivalent.

6-41.30 CONSTRUCTION. Construction shall be of high quality with no internal or visible defects in the finished product. Dimensions shall be as specified on attached drawings, with an allowable tolerance of ± ¼". When the first order is placed, the Contractor shall complete a sample emblem and submit it to the CO for approval before proceeding with further construction. All joints between dimensional lumber boards shall be simple butt joints.

6-41.31 Preparation of Surface Joints. Wood surfaces to be glued shall be smooth and true, free from chips or loosened grain. Surfaces shall be free from dust, grease, and other foreign matter.

6-41.32 Temperature. During the glue application and curing process, air temperatures shall be not less than 70°F nor more than 90°F.

6-41.33 Glue Application. Glue shall be applied in accordance with manufacturer's recommendations to the entire surface of each joint face. Maximum allowable time between start of glue application and final setting of clamps on the sign panel shall be in accordance with manufacturer's recommendations.

6-41.34 Clamping and Curing. Clamping pressure and curing times shall conform to manufacturer's recommendations. Allow to cure 48 hours prior to any machining.

6-41.35 Coregap Filling. Edge coregap holes shall be filled with Mameco International Vulkem 116 polyurethane sealant, Thiokol Pecora Synthacalk GC-9 polysulfide sealant, or CO-approved equivalent to produce a flat, gap-free surface. Edge filler shall be cured in accordance with manufacturer's recommendations, and then sanded smooth.

6-41.36 Chamfered Edges. Following the cutting of the emblem panel to size, all face edges shall be chamfered 45° to resemble the flaking of an arrowhead. Chamfer depths are determined by the chamfer width, which is fixed for each emblem size by the proportions shown on drawing no. PG-1005-A (see figure 2).

6-41.40 GRAPHIC LAYOUT. Graphic layout shall be as shown on attached drawing no. PG-1005-A (see figure 2). Artwork is to be accurately reproduced, enlarged in size to meet the specified vertical dimensions. Allowable reproduction tolerance is $\pm \frac{1}{2}\%$. An accurate grid shall be used to insure layout is level and plumb.

6-41.41 Routing. Letters and graphics shall be routed in accordance with the following table.

Emblem Size		Routing Depth
10''	x 8''	$\frac{1}{8}$ ''
12''	x 9½''	$\frac{1}{8}$ ''
15½''	x 12¼''	$\frac{1}{8}$ ''
18''	x 14¼''	$\frac{1}{4}$ ''
27''	x 21½''	$\frac{1}{4}$ ''
40''	x 31¾''	$\frac{3}{8}$ ''
	and larger	$\frac{3}{8}$ ''

6-41.50 FINISHING.

6-41.51 Sanding. All burrs on edges or routed channels shall be removed by sanding with the grain of the wood. Final sanding shall be with an 80 or 100 medium-grit sandpaper and shall leave the sign face, back, and edges smooth without gouge marks.

6-41.52 Cleaning. All sign surfaces shall be wiped, airblown, or vacuumed clean before painting or staining to insure removal of sawdust.

6-41.53 Painting. All painting shall be accomplished in a well-ventilated, dust-free paint room separated by full partitions from woodworking areas. Paint shall be applied and allowed to cure at air temperatures specified by the manufacturer. Paint shall be thoroughly mixed prior to each use and at frequent intervals during use to insure against pigment separation. Paint shall be applied to all surfaces in a minimum of four coats to provide a dry paint film thickness of 4 mils $\pm \frac{1}{2}$ mil. Color schedule shall be as specified on supplementary drawing.

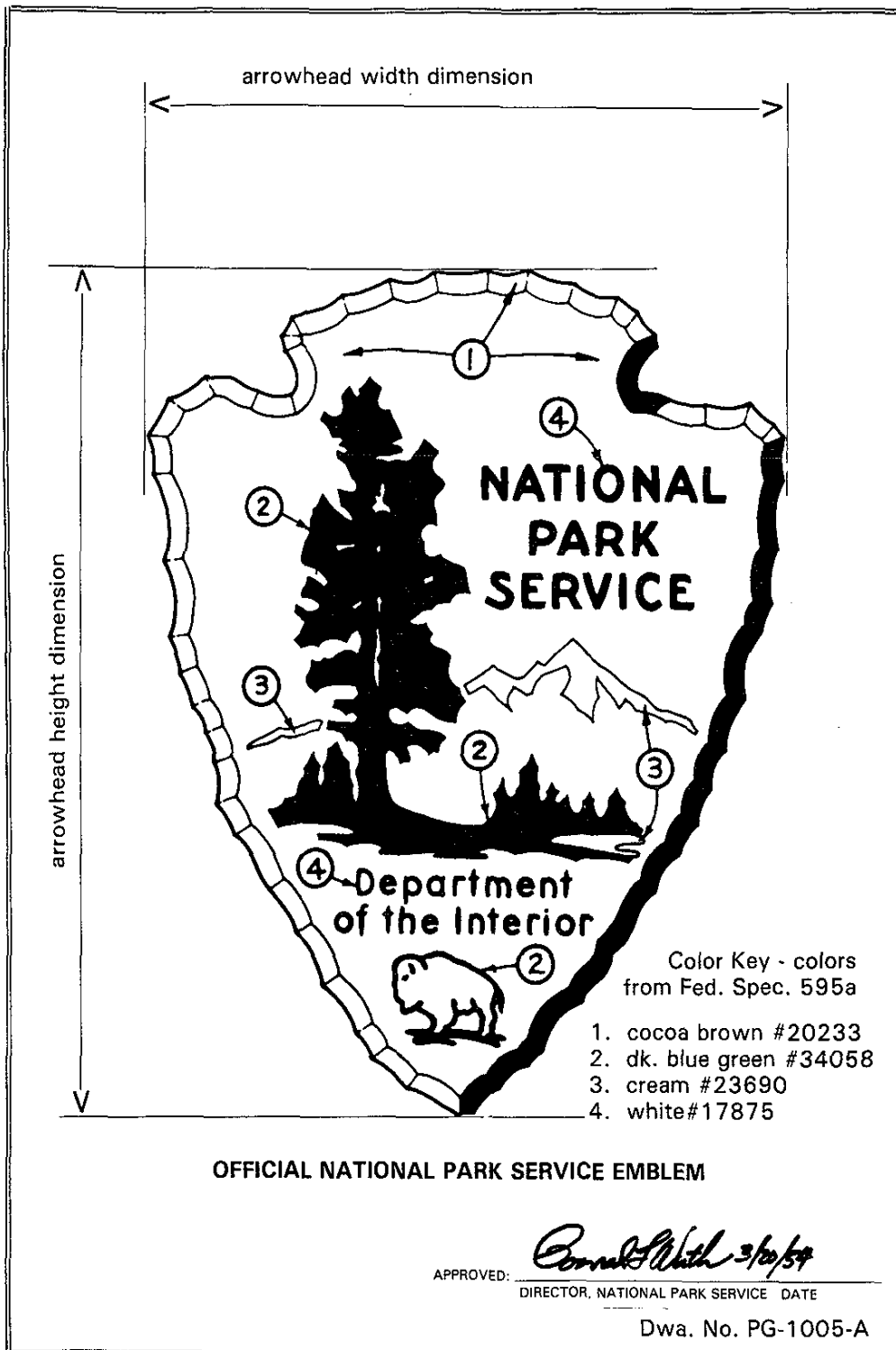

Figure 2

Two coats shall be applied by brush or spray to provide continuous primer across all sign surfaces. Finish paint in routed areas of sign face shall be applied by brush, spray or puddling, providing coverage of entire vertical portion of routed areas. Finish paint on sign face, back, and edges shall be applied by spray or roller. Short nap roller is recommended to prevent paint from dripping into routed areas. Drying time between coats shall be specified by the paint manufacturer.

Signs which show alligating, nicks, or slopping of paint in and around routed areas shall be rejected.

6-41.60 METHOD OF MEASUREMENT. The method of measurement for emblems where the unit is listed as *each* shall be the actual number of emblems completed and accepted.

6-41.70 BASIS OF PAYMENT. The quantities shall be paid for at the contract price per unit of measurement for each of the particular pay items listed, which payment shall be full compensation for furnishing all materials, labor, equipment, tools, and incidentals needed to complete the work prescribed in the specifications.

6-42 SILKSCREENED EMBLEM DECALS

6-42.10 DESCRIPTION. This specification applies to the furnishings of silk-screened emblem decals as ordered on the attached requisition. This work shall include the furnishing of all materials, labor, tools, equipment, and supplies to construct, package, and ship the emblem via Government Bill of Lading or Parcel Post.

6-42.20 MATERIALS.

6-42.21 Substrate.

6-42.21a Aluminum. The aluminum substrate shall be 6061-T6 and otherwise be in conformance with ASTM STD B-209. The thickness shall be 0.080 inches for all emblems.

6-42.21b Plywood. This shall be High Density Overlay (HDO), two sides, 3/4-inch 7-ply, Douglas fir, exterior plywood, Product Standard PS 1-74, Group 1, with a B grade veneer on both faces. *Mill-oiled concrete form plywood shall be prohibited.* Surfacing overlay material weight shall be high density 60-60, non-oiled, resin impregnated fiber permanently fused to the base panel under heat and pressure. Panel weight shall be approximately 2.2 pounds per square foot. Overlay color shall be black. Each panel shall be edge-branded HDO B-B G1 EXT PS 1-74. The Contractor shall supply the CO with APA certification that the plywood meets all the above requirements.

6-42.22 Background Sheeting. Sheeting materials shall comply with "Standard Specifications for Construction of Roads and Bridges on Federal Highway Projects," FP-85 and Federal Specification L-S-300C. Contractor shall furnish certification that the materials comply with the requirements of FP-85 and L-S-300C. Contractor shall indelibly mark each carton of materials showing the date received. No more than 12 months shall have elapsed from date of purchase from the manufacturer to the date of application on substrate. Background sheeting shall be Type II, Class 1 or 2 and the color shall be white.

6-42.22a Reflective Emblem Colors. All of the following 3M Co. Screen Process inks or CO-approved equivalents, will be used as specified.

BORDER SHADOW: Opaque Black, No. 725

TREE: Green, No. CF 263

Color Formula for Green

		<i>Weight</i>
Opaque Color 23-817 Lt. Green	.152	1 lb. 15 3/4 oz.
Opaque Color 23-805 White	.136	2 lb. 1 1/2 oz.
Opaque Color 725 Black	.239	1 lb. 15 3/4 oz.
Opaque Color 23-872 Dk. Green	.473	5 lb. 0 oz.
		11 lb. 1 oz.

NOTE: May substitute Naz Dar #59-148 Dark Green.

BACKGROUND: Cocoa Brown, No. CF 890-3

Color Formula for Cocoa Brown

		<i>Weight</i>
Transparent Color 713 Rustic Brown	.330	2 lb. 9 1/2 oz.
Transparent Color 707 Toner	.650	5 lb. 4 oz.
Transparent Color 722 Yellow	.20	0 lb. 2 1/2 oz.
		8 lb. 0 oz.

MOUNTAIN, LAKE, AND TEXT: White Reflective Sheeting.

6-42.22b Nonreflective Emblem Colors. All of the following screen process inks or CO-approved equivalent will be used as specified.

6-42 SILKSCREENED EMBLEM DECALS

6-42.10 DESCRIPTION. This specification applies to the furnishings of silk-screened emblem decals as ordered on the attached requisition. This work shall include the furnishing of all materials, labor, tools, equipment, and supplies to construct, package, and ship the emblem via Government Bill of Lading or Parcel Post.

6-42.20 MATERIALS.

6-42.21 Substrate.

6-42.21a Aluminum. The aluminum substrate shall be 6061-T6 and otherwise be in conformance with ASTM STD B-209. The thickness shall be 0.080 inches for all emblems.

6-42.21b Plywood. This shall be High Density Overlay (HDO), two sides, 3/4-inch 7-ply, Douglas fir, exterior plywood, Product Standard PS 1-74, Group 1, with a B grade veneer on both faces. *Mill-oiled concrete form plywood shall be prohibited.* Surfacing overlay material weight shall be high density 60-60, non-oiled, resin impregnated fiber permanently fused to the base panel under heat and pressure. Panel weight shall be approximately 2.2 pounds per square foot. Overlay color shall be black. Each panel shall be edge-branded HDO B-B G1 EXT PS 1-74. The Contractor shall supply the CO with APA certification that the plywood meets all the above requirements.

6-42.22 Background Sheeting. Sheeting materials shall comply with "Standard Specifications for Construction of Roads and Bridges on Federal Highway Projects," FP-85 and Federal Specification L-S-300C. Contractor shall furnish certification that the materials comply with the requirements of FP-85 and L-S-300C. Contractor shall indelibly mark each carton of materials showing the date received. No more than 12 months shall have elapsed from date of purchase from the manufacturer to the date of application on substrate. Background sheeting shall be Type II, Class 1 or 2 and the color shall be white.

6-42.22a Reflective Emblem Colors. All of the following 3M Co. Screen Process inks or CO-approved equivalents, will be used as specified.

BORDER SHADOW: Opaque Black, No. 725

TREE: Green, No. CF 263

Color Formula for Green

		<i>Weight</i>
Opaque Color 23-817 Lt. Green	.152	1 lb. 15 3/4 oz.
Opaque Color 23-805 White	.136	2 lb. 1 1/2 oz.
Opaque Color 725 Black	.239	1 lb. 15 3/4 oz.
Opaque Color 23-872 Dk. Green	.473	5 lb. 0 oz.
		11 lb. 1 oz.

NOTE: May substitute Naz Dar #59-148 Dark Green.

BACKGROUND: Cocoa Brown, No. CF 890-3

Color Formula for Cocoa Brown

		<i>Weight</i>
Transparent Color 713 Rustic Brown	.330	2 lb. 9 1/2 oz.
Transparent Color 707 Toner	.650	5 lb. 4 oz.
Transparent Color 722 Yellow	.20	0 lb. 2 1/2 oz.
		8 lb. 0 oz.

MOUNTAIN, LAKE, AND TEXT: White Reflective Sheeting.

6-42.22b Nonreflective Emblem Colors. All of the following screen process inks or CO-approved equivalent will be used as specified.

panel edges prior to application of reflective sheeting. One coat of the enamel shall be applied after application of reflective sheeting.

Cure time between enamel coats shall be as specified in writing by the manufacturer. Prime plus paint thickness shall provide a minimum of 2 mils \pm 1/2 mil thickness of dry paint film.

6-42.32d Panel Face Cleaning. Successful adhesion of reflective sheeting is dependent upon a totally clean and well-scarified panel face to receive the adhesive. Before application of the sheeting, the face shall be free of all foreign matter such as paint or dust.

6-42.33 Metalworking. The aluminum shall be free of burrs and pits on both sides, including edges and holes, and shall be made ready for application of the sheeting.

6-42.33a Surface Preparation. The aluminum shall be thoroughly cleaned and degreased with solvent and alkaline emulsion cleaner by immersion, spray, or vapor degreasing and dried prior to application of the sheeting coat. The aluminum shall be new and corrosion-free with holes drilled or punched, and all edges smoothed prior to application of the sheeting.

6-42.34 Application Methods. The method of application of sheeting shall be precisely as prescribed in writing by the manufacturer of the sheeting.

The applicator shall have at least two pyrometers centrally attached. The applicator shall also have a cycle control unit approved by the sheeting manufacturer.

Temperature control calibration and accuracy monitoring of the approved cycle control unit shall be required each day that the heat and vacuum applicator is operated.

"Teletemp Temperature Records" (temperature measuring devices) shall be used.

Applicator operating temperature shall be calibrated with the specified temperature measuring device each day of operation, and:

1. Whenever different substrate materials are being used.
2. Whenever a diaphragm, light-bulb, cycle-control unit, or thermocouple is replaced.
3. Whenever different types or different colors of reflective sheeting are used.

The sheeting shall be precut to size or trimmed to the edges. The entire face of the panel shall be covered with one unspliced sheet.

Flexible sheeting shall be positioned to provide 1/8-inch to 5/32-inch overlap onto all panel edges after trimming. Use of two reflective faces on one panel (dual face) is prohibited.

6-42.35 Silkscreening. Screen processing shall be of careful workmanship with neat, clean lines and corners, performed strictly as prescribed by the manufacturer of the transparent or opaque colors. The screen inks shall be drawn over the screen with a firm, even pressure. As needed, three to five minutes shall be allowed for the ink to flow out so that it has a smooth surface.

6-42.40 LAYOUT. Exact layout to the specified size on attached requisition shall be produced by the Contractor by enlarging the attached drawing.

6-42.50 FINISHING. Not Applicable.

6-42.60 METHOD OF MEASUREMENT. The method of measurement for emblems where the unit is listed as *each* shall be the actual number of emblems completed and accepted.

6-42.70 BASIS OF PAYMENT. The quantities shall be paid for at the contract price per unit of measurement for each of the particular pay items listed, which payment shall be full compensation for furnishing all materials, labor, equipment, tools, and incidentals needed to complete the work prescribed in the specification.

6-50 PACKAGING, ORDERING, AND SHIPPING

CONTENTS

6-51	PACKAGING
6-51.10	ALL SIGNS
6-51.11	Reflective Sign Packaging
6-51.12	Small Routed Wooden Sign Packaging
6-51.13	Large Routed Wooden Sign Packaging
6-52	SHIPPING
6-52.10	FROM COMMERCIAL SOURCES

6-50 PACKAGING, ORDERING, AND SHIPPING

6-51 PACKAGING

6-51.10 ALL SIGNS. Signs protected as required below shall be packaged according to individual Areas. Signs ordered by two or more Areas shall not be placed in the same package.

The sign package shall be strapped with a viscose webbing strapping system, "Avistrap," or an equivalent approved by the Contracting Officer (CO), with not less than two straps, cinched down tight to prevent any movement or chafing.

After the bundle is strapped, the Contractor shall place a copy of the sign requisition and invoice in a heavily constructed envelope and attach it securely to the package.

The painted portions of signs, symbols, and shields shall be covered with slip sheets. Stained signs shall not be covered with slip sheets. All signs packaged together shall be turned face to face.

6-51.11 Reflective Sign Packaging. Signs shall be wiped clean prior to packaging.

Signs may be packaged singly or in multiples, provided that the individual weight of sign packages does not exceed 90 pounds. Signs may be packaged in fiberboard boxes, provided that the boxes conform to Federal Specifications PP-636-H; Type CF (corrugated fiberboard); Class - Domestic, Variety DW (double wall); Grade 275. Signs packaged separately shall have the sign face covered with 1/8 inch pressed board, smooth side toward the sign face.

Signs may be taped together prior to packaging with filament tape only if slip sheets completely cover the exposed surface of the signs prior to taping.

Sign faces, or a sign face and the pressed board, shall be separated by liners removed from reflective sheets (plastic side down), with the exception of Type III sheeting which shall be separated by 3M SCW 822 slip sheets or CO-approved equivalent.

6-51.12 Small Routed Wooden Sign Packaging. All sawdust shall be removed from the finish sign prior to packaging for shipment. The face of each sign shall be separated with corrugated packaging paper that meets Federal Specification PPP-P-291E, Type I (light duty), Style 1 (backing sheet mandatory). Signs shall be shipped in packages weighing not more than 65 pounds. Each package shall be wrapped in corrugated wrapping paper which meets Federal Specifications PPP-P-291E; Type III (heavy duty); Style 1 (backing sheet mandatory). Fiberboard boxes may be used as specified in 6-51.11.

6-51.13 Large Routed Wooden Sign Packaging. Signs shall be packaged separately. Required arrowhead emblems or logo plaques shall be included with each sign and shall be strapped, or otherwise affixed securely to a cleat and faced against the back of the sign.

All signs shall be packaged with the smooth side of the 1/8 inch thick nontempered, pressed board covering the sign face. The pressed board shall be well-secured with 4-penny, cement-coated nails, to the protective strips nailed to the signboard edges. Protective strips of nominal 2" x 4" lumber shall be extended past all sign board corners so as to join for nailing.

The package shall then be wrapped with corrugated wrapping paper as specified in 6-51.12.

6-52 SHIPPING

6-52.10 FROM COMMERCIAL SOURCES. Shipments shall be via Government Bill of Lading (GBL), or by the most economical method, such as Parcel Post, prepaid, and added as a separate item on the invoice.

**6-60 APPLICABLE DOCUMENTS, PUBLICATIONS,
AND STANDARDS**

CONTENTS

6-61	DESCRIPTION
6-61.10	FEDERAL SPECIFICATIONS AND STANDARDS
6-61.20	MILITARY SPECIFICATIONS AND STANDARDS
6-61.30	MANUAL ON UNIFORM TRAFFIC CONTROL DEVICES (MUTCD)
6-61.40	OTHER

6-60 APPLICABLE DOCUMENTS, PUBLICATIONS, AND STANDARDS

6-61 DESCRIPTION The following documents are a part of these specifications to the extent specified and as currently amended.

6-61.10 FEDERAL SPECIFICATIONS AND STANDARDS

Standard or Specification	Description
QQ-S-775	Steel sheets, carbon, zinc-coated.
FS-595a	Colors.
TT-P-25E	Primer Coating, exterior (undercoat for wood ready-mixed, white and tints).
FED-STD-141	Paint, varnish, lacquer, and related materials. Method of inspection, sampling and testing.
L-S-300C	Sheeting and tape, reflective and nonreflective; nonexposed lens, adhesive backing.
MMM-A-181C	Adhesive, phenol resorcinol, or malamine base.
TT-C-1060A	Coating, compound, reflective.
TTS-S-708A	Stain, oil: semi-transparent, wood, exterior.
PPP-B-636H	Boxes, shipping fiberboard.
PPP-P291 E	Paperboard, wrapping, and cushioning.

6-61.20 MILITARY SPECIFICATIONS AND STANDARDS

Standard or Specification	Description
MIL-43719 and MIL-M-43719	General Specifications for adhesive, elastomeric, and pigmented marking materials and markers.

6-61.30 MANUAL ON UNIFORM TRAFFIC CONTROL DEVICES (MUTCD).

Includes (1) Standard Alphabets for Highway Signs, (2) Standard Highway Signs Book and, (3) Specifications for Standard Highway Sign Colors.

Copies of the above MUTCD and the Standard Highway Signs Book are available from the Superintendent of Documents, U.S. Government Printing Office, Washington, D.C. 20403. The subsidiary documents (Standard Alphabets for Highway Signs and Specifications for Standard Highway Sign Colors) are available from the Federal Highway Administration, Office of Traffic Operations, Washington, D.C. 20590.

6-61.40 OTHER

Standard or Specification	Description
U.S.-PS-1-74	U.S. Products Standard No. 1-74; for softwood plywood, construction and industrial (Application for copies should be addressed to the Products Standards Section, National Bureau of Standards, Washington, D.C.).

ASTM-STD-B-208

American Society of Testing and Materials.
(Application for copies should be addressed to the Executive Secretary, American Society for Testing and Materials, 1916 Race St., Philadelphia, PA 19103)

APA Test STD

American Plywood Association Test Standard Preliminary Tests for Exterior Coatings.

(Application for copies should be addressed to the Executive Secretary, American Plywood Association, 119 A St., Tacoma, Washington 98401.

FP-85

Standard Specifications for Construction of Roads and Bridges on Federal Highway Projects, Section 718.

Copies of Section 718 are available from the Federal Highway Administration, Office of Traffic Operations, Washington, D.C. 20590.

LM-PB

Product Bulletin for Colors and Clears.

LM-IF

Color Application Installation.

CS 122-60

U.S. Commercial Standards.

CS 259-63

U.S. Commercial Standards.

6-70 QUALITY CONTROL

CONTENTS

6-71	PLYWOOD
6-71.10	PLYWOOD TESTS
6-71.11	Contamination Test
6-71.12	Adhesion Test
6-72	TEMPERATURE CALIBRATION
6-72.10	HEAT AND VACUUM APPLICATOR
6-72.20	TEST PROCEDURE
6-73	PAINT
6-73.10	PAINT THICKNESS
6-74	CERTIFICATION
6-74.10	MATERIALS CERTIFICATION
6-75	INSPECTION AND ACCEPTANCE
6-75.10	SIGNS ORDERED FROM COMMERCIAL SOURCES
6-76	GUARANTEE
6-76.10	REFLECTORIZED SIGN
6-76.20	ROUTED WOOD SIGNS

6-70 QUALITY CONTROL

6-71 PLYWOOD

6-71.10 PLYWOOD TESTS. The Contractor shall furnish copies of the vendor's invoice for the plywood, including certification that the plywood meets the following test requirements.

6-71.11 Contamination Test. The plywood contamination test panels shall be cut three inches long and two inches wide. The panels shall be wiped with a tack rag to remove any dust or loose particles, and then the required reflective sheeting shall be applied to both faces of the panels. The test panels shall be conditioned for 24 hours at room temperature (75 °F), and then placed in a pressure vessel and held submerged in cold tap water. A vacuum of 24 inches of mercury shall be drawn and maintained for 45 minutes, followed immediately by the application of 40 to 50 psi of water pressure for 45 minutes.

NOTE: Proper test procedures are assured if the panel does not float after the above treatment.

Test panels shall then be removed from the pressure vessel and each placed in a glass container (400 ml beaker) containing approximately 50 ml of water. The beaker shall then be covered with a glass lid, such as a petri dish, and placed in an oven at 150 ° for 24 hours. At the end of the 24 hour interval, remove the panel from the oven, wipe the sheeting surface to remove any residue, and visually examine for deterioration. Any evidence of staining, discoloration, or other degradation of the applied sheeting shall constitute failure of the plywood to comply with the specification.

6-71.12 Adhesion Test. Panels of the plywood selected for adhesion testing shall be cut approximately one foot square. The application surfaces of the panels shall be cleaned. The reflective sheeting or film shall be cut to the appropriate size for completely covering the prepared, dust-free plywood surface in accordance with the recommendations of the sheeting or film manufacturer. The panels shall be subjected to accelerated conditioning in an oven for one hour at 150 °F, then cooled to room temperature. The sheeting or film shall be struck with a test spatula, using short, sharp jabs. The adhesive bond shall resist removal other than in small pieces at the point of spatula impact.

NOTE: Plywood (HDO) shall be certified for adhesion and shall be free of contamination in compliance with PS-1-74 and the applicable American Plywood Association (APA) requirements. This certification is to ensure that the high density overlay is of a suitable quality for application of reflective sheeting and paint.

6-72 TEMPERATURE CALIBRATION

6-72.10 HEAT AND VACUUM APPLICATOR. Teletemp Temperature Recorders (temperature-measuring devices) shall consist of a graded series of three heat-sensitive papers calibrated at 180 °, 190 °, and 200 °F to measure temperature accurately by means of a change in color. Each paper shall show an irreversible color change from white to black at a specific temperature. Accuracy of color change shall be within two percent of indicated temperature. Stored indicators shall be kept clean, dry, and at less than 80 °. Response time shall not exceed two seconds. See the following procedures and tables.

6-72.20 TEST PROCEDURE.

1. Allow the applicator temperature control to warm up at least ½ hour.
2. Allow the heat and vacuum applicator to warm up by running at least two complete cycles.
3. Peel teletemp temperature measuring device from tape backing. Place device on top of sign face, on an unscreened section of the material.
4. Place the test sign face in the heat and vacuum applicator, near the center of the diaphragm and under the thermister.
5. Place a slip sheet, glossy side down, over the sign face. Turn the vacuum on. Lower the diaphragm. Adjust sign face position so that the temperature measuring device is not on a diaphragm seam or under the thermister-patched area.
6. Run a complete cycle. Remove the test sign face. Compare temperature measuring device readings to the following table. Make adjustments as indicated.
7. Remove the temperature measuring device from the sign face. Place the device on the calendar for the corresponding day. Place all devices used for test evaluations on the calendar.

Temperature-Measuring Device Reading	Action Required For Sheeting	
	Type II	Type III
None blacked out	Temperature is too low. Increase temperature and re-run test.	Temperature is too low. Increase temperature and re-run test.
80 °F blacked out	Temperature is too low. Increase temperature and re-run test.	Temperature is in correct range.
80 °F, 190 ° blacked out	Temperature is too low. Increase temperature and re-run test.	Temperature is too high. Decrease temperature and re-run test.
80 °, 190 °, and 200 °F blacked out	Temperature is within correct range.	Temperature is too high. Decrease temperature and re-run test.

NOTE: For 5 by 12 foot applicator only.

6-73 PAINT

6-73.10 PAINT THICKNESS. Dry film thickness shall be tested periodically by use of a commercial film thickness tester. Such test results by the Contractor shall be furnished to the Contracting Officer (CO) upon request.

6-74 CERTIFICATION

6-74.10 MATERIALS CERTIFICATION. It is the responsibility of the sign Contractor to obtain materials certification from each manufacturer of substrates, adhesives, sheeting, and coatings, and to see that the material meets all requirements as specified in this and related documents.

The sign Contractor shall also provide certification that the finished product meets all of the requirements specified in this document and that all other certifications are on file and available to the CO on request.

6-75 INSPECTION AND ACCEPTANCE

6-75.10 SIGNS ORDERED FROM COMMERCIAL SOURCES. Inspection and acceptance shall be in accordance with the General Provisions, Standard Form 23A.

6-76 GUARANTEE

6-76.10 REFLECTORIZED SIGNS. The Contractor shall warrant the materials and workmanship of each sign in accordance with the maximum limits of material warranties extended by manufacturers of raw materials, subject to the conditions they specify, and the production specifications provided by the National Park Service. In general, signs are expected to maintain a useful life span of at least five years. When sign failure occurs prior to five years and an inspection demonstrates that the failure is caused by materials warranted to Contractor to endure at least that long, the sign will be replaced or repaired free of materials charges. When failure occurs and inspection demonstrates that such failure is due to poor workmanship, the sign will be replaced or repaired at Contractor's expense, including shipping charges.

6-76.20 ROUTED WOOD SIGNS. Contractor shall guarantee materials and workmanship of signs for two years from the date of the maker's mark. Contractor shall be liable for total replacement cost of signs including materials, fabrication costs and shipping, at the time of failure of original materials and/or workmanship.

6-80 MISCELLANEOUS APPURTENANCES

CONTENTS

6-81	DESCRIPTION
6-82	MATERIALS
6-82.10	BACKING STIFFENERS
6-82.20	SIGN MOUNTING HARDWARE
6-82.30	METAL TUBING
6-83	SIGN SUPPORTS
6-83.10	STEEL POST SELECTION
6-83.20	TIMBER POST SELECTION
6-83.30	TIMBER POST BREAKAWAY
6-83.40	SIGN BRACING

6-80 MISCELLANEOUS APPURTENANCES

6-81 DESCRIPTION. This item shall consist of furnishing the specified hardware materials as ordered on the sign requisitions. This work shall include the furnishing of all materials, labor, tools, equipment, and supplies to construct; packaging for shipping; obtaining carrier; and shipping the signs via Government Bill of Lading.

6-82 MATERIALS

6-82.10 BACKING STIFFENERS. Backing stiffeners, when specified, shall be 3" 6061-T6 aluminum zees, 2.33 lbs/ft. (Fentron Highway Products, Seattle, Washington) or CO-approved equivalent. Unless otherwise specified, stiffeners will be provided on signs sized at 32" high and 48" wide or larger. Stiffeners shall be installed as shown.

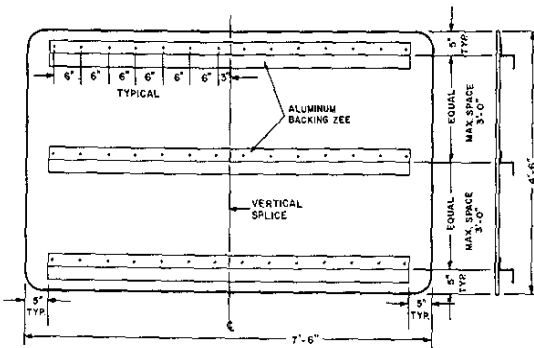

PLYWOOD SIGN PANEL

STEEL POST	WOOD POST	2024-T4 ALUMINUM SIZES ARE MINIMUM		
		BOLT SIZE	NUT SIZE	WASHER SIZE
2" x 2"		3/8" x 3/8"	3/8"	1" O.D. 7/16" I.D.
4" x 2 1/2"	4" x 4"	3/8" x 1/2"	3/8"	1" O.D. 7/16" I.D.
4" x 6"	4" x 6"	3/8" x 7/8"	3/8"	1" O.D. 7/16" I.D.
	6" x 6"	3/8" x 7/8"	3/8"	1" O.D. 7/16" I.D.

NOTE:
 ALUMINUM BACKING ZEES ARE TO BE INSTALLED ON PLYWOOD SIGNS HAVING A MINIMUM SIZE OF 42" WIDE 30" HIGH.
 ALL PLYWOOD SIGN REQUIRING VERTICAL SPLICES SHALL HAVE A MINIMUM OF TWO ALUMINUM BACKING ZEES.

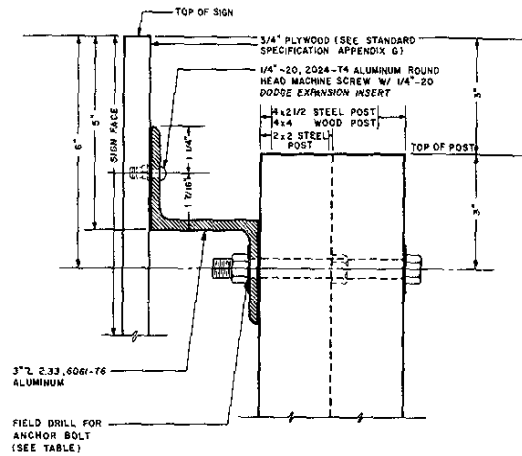

ALUMINUM BACKING ZEE DETAIL

ALUMINUM BACKING ZEES AND SIGN BACKS SHALL BE PAINTED BEFORE ATTACHING BACKING ZEES.

6-82.20 SIGN MOUNTING HARDWARE. Vandal-resistant hardware shall be used where possible. This hardware shall be as manufactured by THE TUFNUT WORKS, 236 Montezuma Street, Santa Fe, New Mexico 87501, (505) 983-2522, or CO-approved equivalent.

6-82.30 METAL TUBING (WEATHERING STEEL). Hot rolled, flashing, welded mechanical steel tubing ASTM A 500.

EXAMPLE

VANDLGARD-NUT-INSTALLATION AND REMOVAL

INSTALLATION

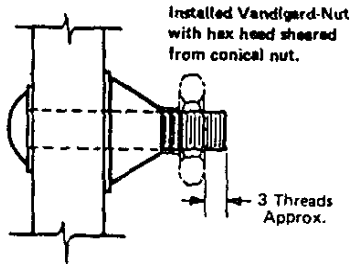

1. Install Vandgard nut by tightening hex until it shears.
2. Use nylon washers.

REMOVAL

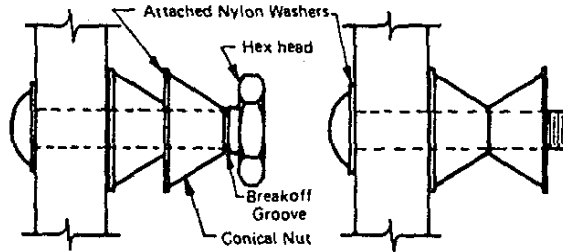

1. Thread on second Vandgard and twist off hex. Remove the remaining conical nut.
2. Install this conical nut in the inverted position.

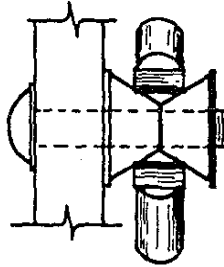

3. Squeeze both nuts firmly with vise-grips and remove both nuts together.

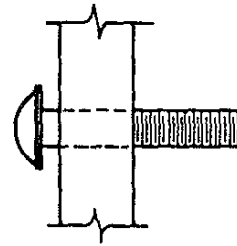

4. Original bolt is undamaged and ready for reuse.

Available from:

Federal Prison Industries

Voi-Shan, P.O. Box 512
Culver City, Calif. 90230

Ojo Caliente Craftmen Inc.
Ojo Caliente, N. Mex. 87549

ASSEMBLY COMPONENTS	DESCRIPTION	MATERIAL	FINISH & COLOR
VCB 144	Bolt—5/16-18 x 6" Round head	C1018 Steel or equiv.	Cadmium plate per QQ-P-416 Type II Cl. 2 or zinc plate per QQ-Z-325 Type II Cl. 1 } Olive drab Dichromate
VCN 145-5	Nut—5/16-18 Vandgard	Aluminum alloy QQ-A-430	Anodize per MIL-A-8625 Color: Green
VCW 146	Washer—5/16 I.D. x 7/8 O.D. x 1/16" thick	6/6 Nylon	Brown
VC 147	Complete Hardware Assembly		

EXAMPLE

Sign Installation Hardware "Tufnut" (Pyramidal nuts) Anti-theft, Anti-vandal Fasteners

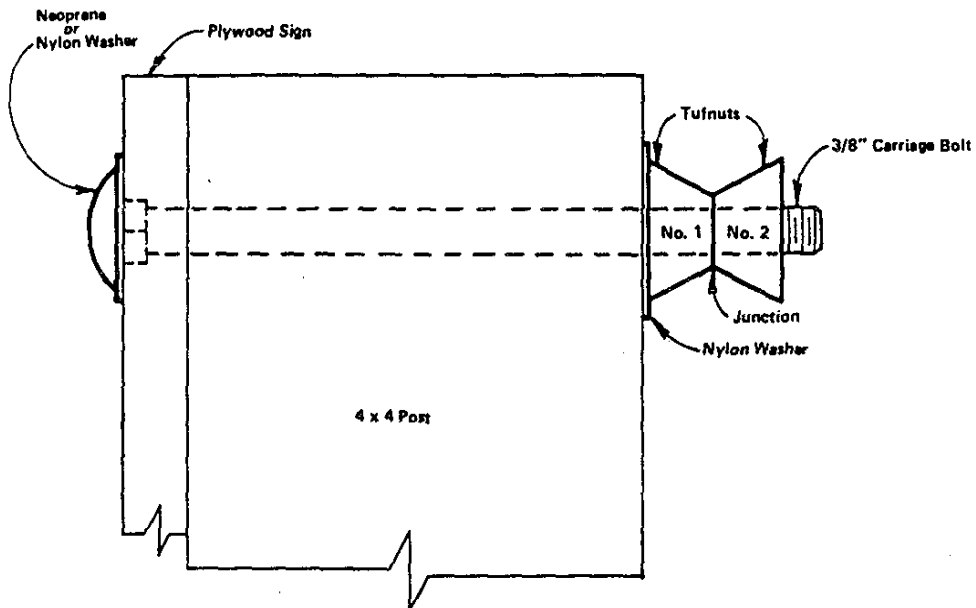

Typical Installation Procedure

- Step 1: Install first Tufnut (No. 1) finger tight as shown.
- Step 2: Install second Tufnut (No. 2) finger tight as shown.
- Step 3: Insert wrench at junction to tighten (or loosen) as necessary.
- Step 4: Remove Tufnut No. 2, then installation is complete.

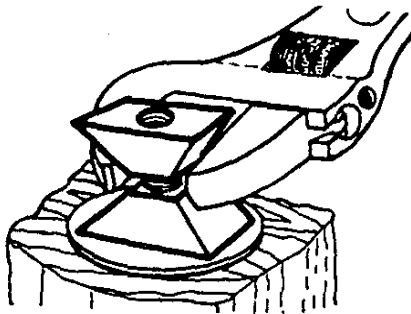

Typical Tufnut
(for 3/8" Carriage Bolt)

(Not to Scale)

Minimum Order—100

Single Tufnut is difficult to remove because of its shape.
Always use (4) Tufnuts for two-post sign installation.

Available from:

Ojo Caliente Craftsmen Inc.
Ojo Caliente, N. Mex. 87549

Tufnut Works
236 Montezuma St.
Santa Fe, N. Mex. 87501

Federal Prison Industries

6-83 SIGN SUPPORTS
6-83.10 STEEL POST SELECTION

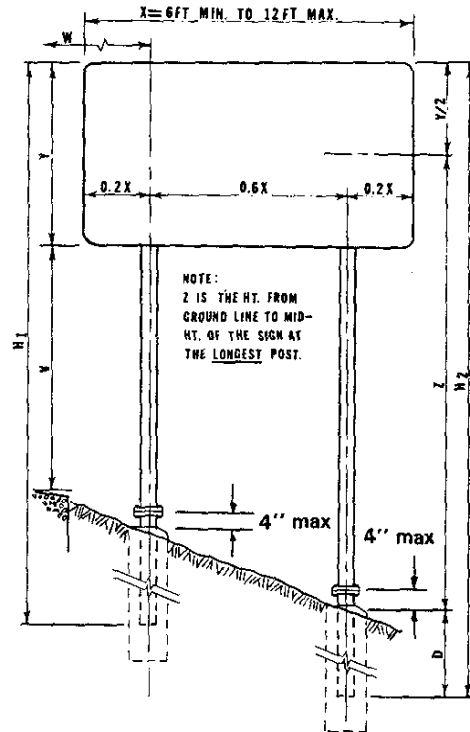
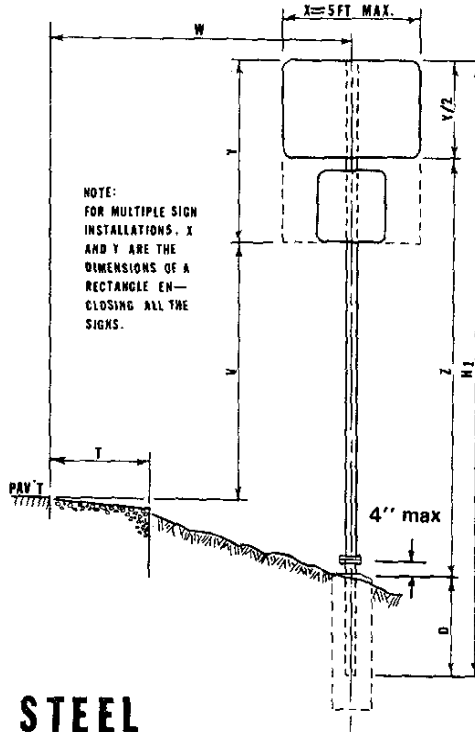

**STEEL
POST SELECTION**

NOTE:
TABLE VALUES SHOWN ARE THE MAX.
PERMITTED, EXCEPT FOR D.

DESIGN EXAMPLE

GIVEN: 15 FT WIDE, 8 FT HIGH SIGN; $X=15'$, $Y=8'$,
3 FT WIDE SHOULDER, WITH .05'/FT SLOPE; $T=3'$,
FROM EDGE OF PAVEMENT TO $\frac{1}{2}$ OF NEAREST POST IS
12 FT; $W=12'$.
STD. MOUNTING HT. IN THIS CASE IS 5 FT; $V=5'$.
EMBANKMENT SLOPE IS 6:1 (1' VERT. DROP FOR
EVERY 6' HORIZ.)

SOLUTION: $Z=1/2$ HT. OF SIGN (Y) + MOUNTING HT. (V) +
SHOULDER WIDTH (T) x SHOULDER SLOPE + DIST.
FROM EDGE OF SHOULDER TO $\frac{1}{2}$ OF LONGEST POST
 $(W-T + .6X)$ x EMBANKMENT SLOPE.

$$Z = Y/2 + V + T(\text{SHOULDER SLOPE}) + (W - T + .6X)(\text{EMBANKMENT SLOPE})$$

$$Z = 8/2 + 5 + (3 \times .05'/\text{ft}) + (12 - 3 + .6(15)) \text{ at } 6:1$$

$$Z = 4 + 5 + .15 + 18 \text{ at } 6:1 = 9.15 + 3 = 12.15$$

$$(X)(Y)(Z) = (15)(8)(12.15) = 1458$$

ANSWER: FROM TABLE SELECT POST(S) HAVING $(X)(Y)(Z)$
OF 1458 OR MORE; USE TWO 6" x 4" POSTS.

CATEGORY 1, 1A, 2, 3.

POST SIZE	NO. OF POSTS	1	2	3	D
	2" x 2" x .095"	69	139	208	3'
4" x 2.5" x .125"	262	524	786	3'	
6" x 4" x .203"	1027	2054	3081	3'	
	(X)(Y)(Z) in FT ³				

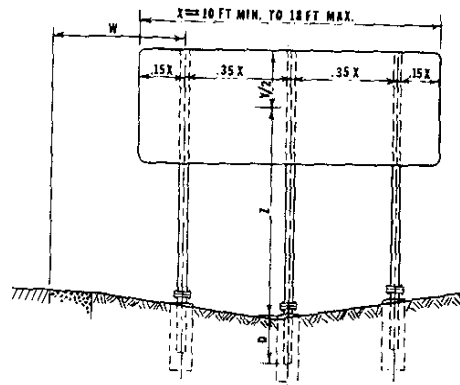

EXAMPLE

Sign faces are installed
on any of four sides

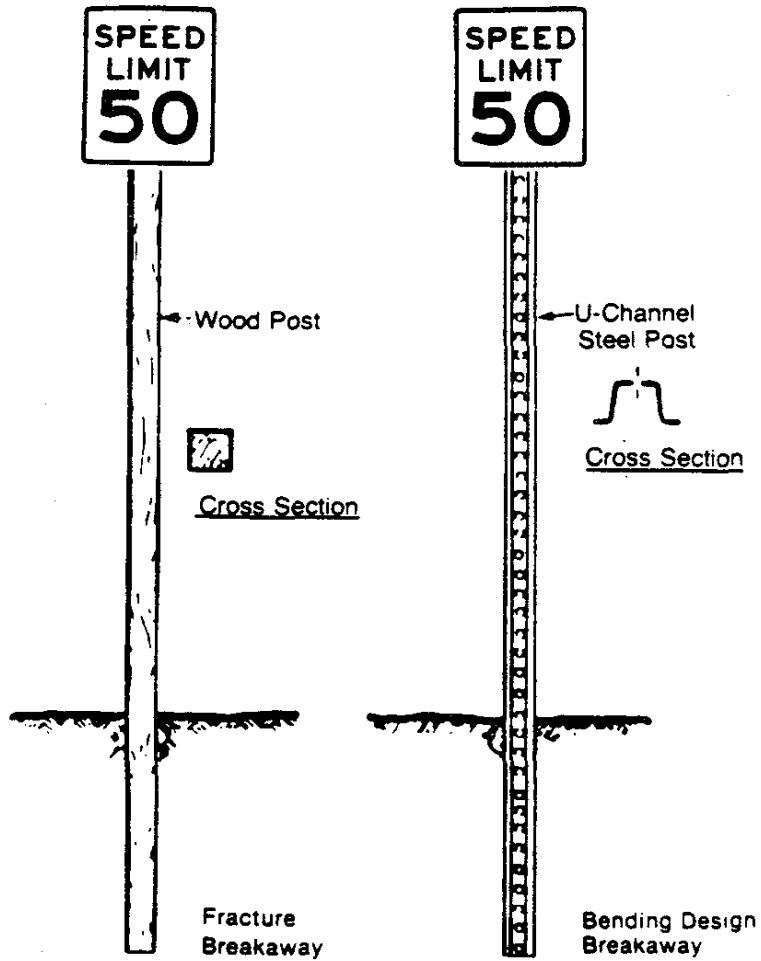

Sign Support Systems

EXAMPLE

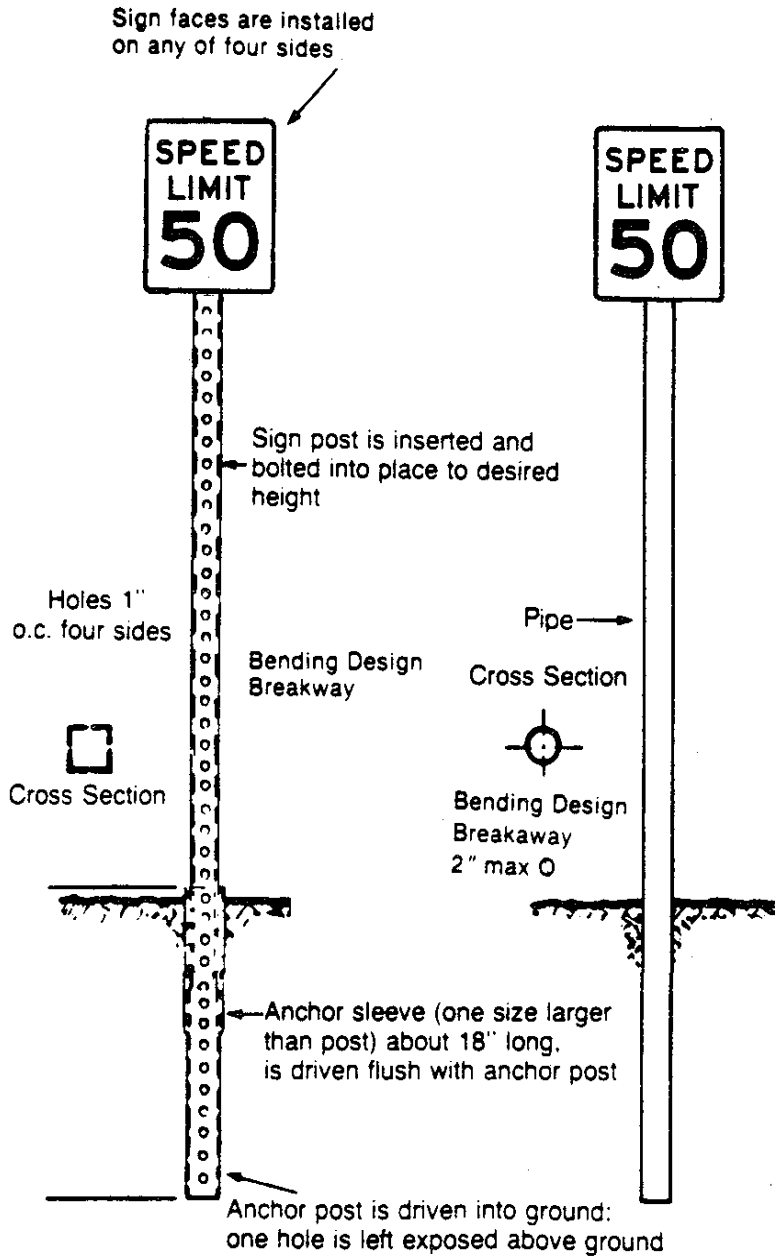

Sign Support Systems

EXAMPLE

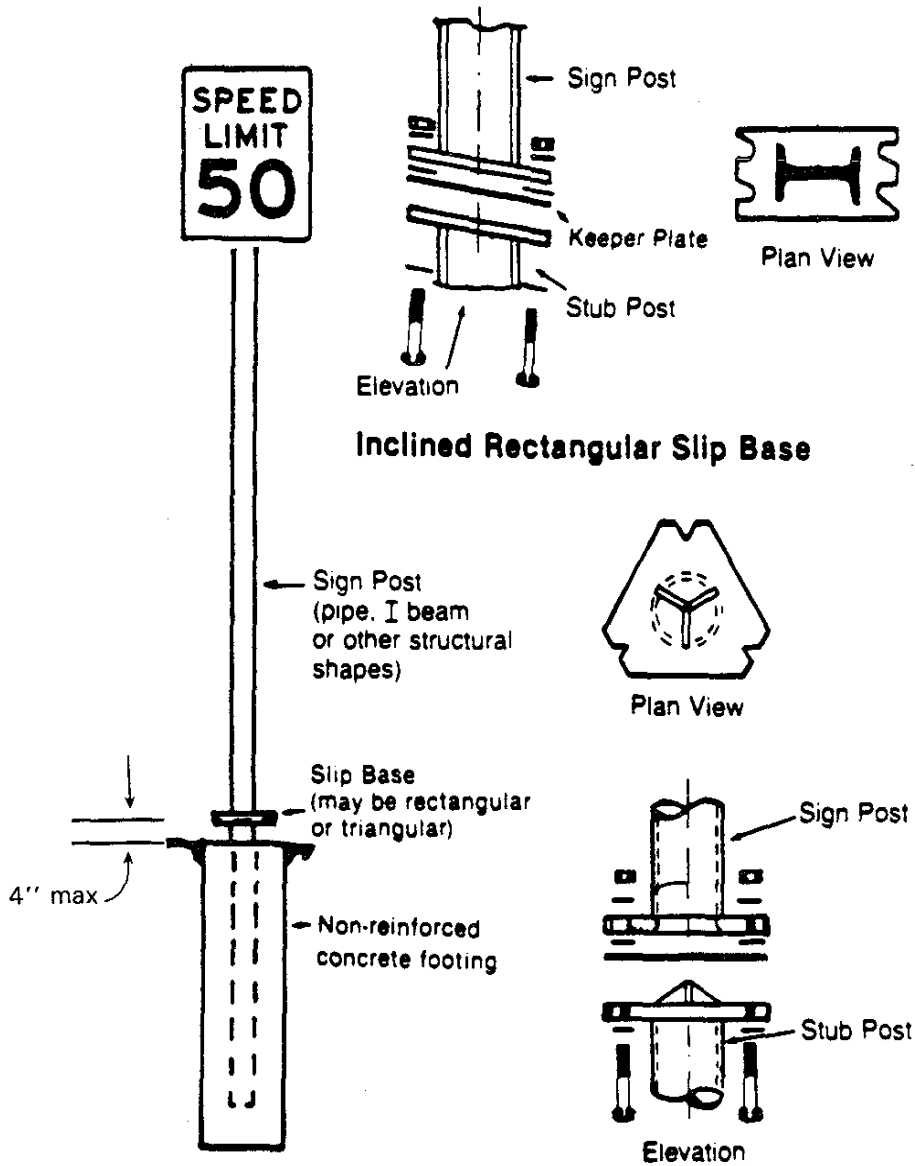

Inclined Rectangular Slip Base

Triangular Slip Base

Sign Support Systems

EXAMPLE

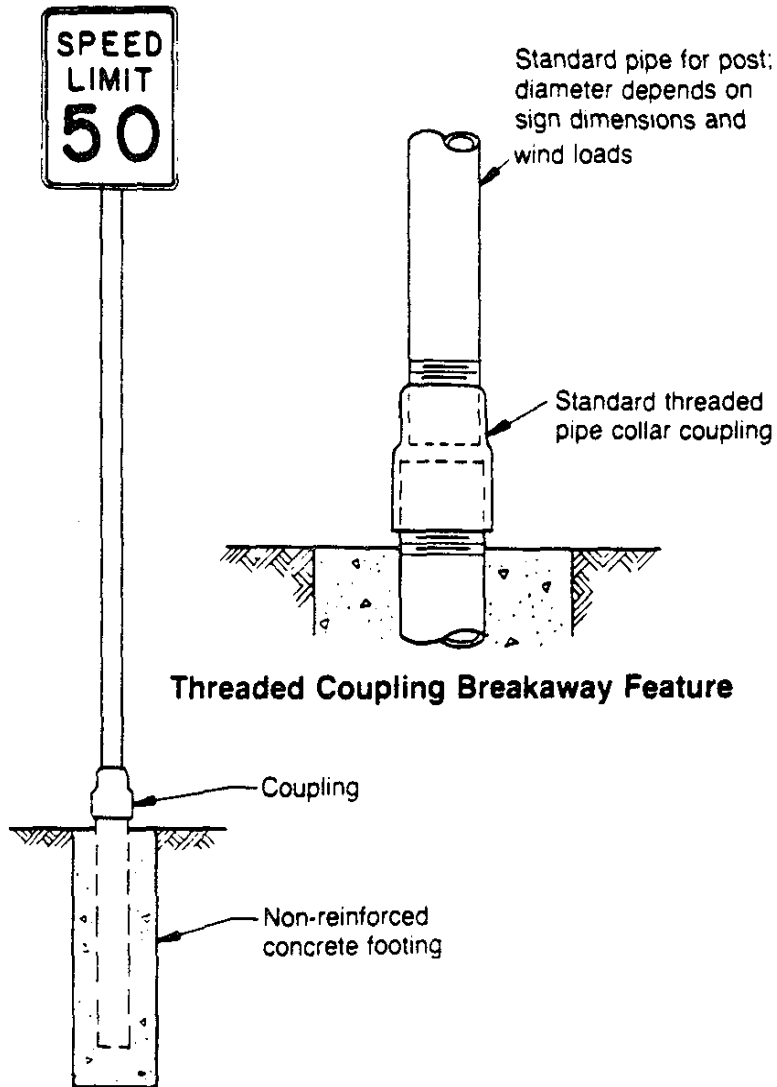

Sign Support Systems

EXAMPLE

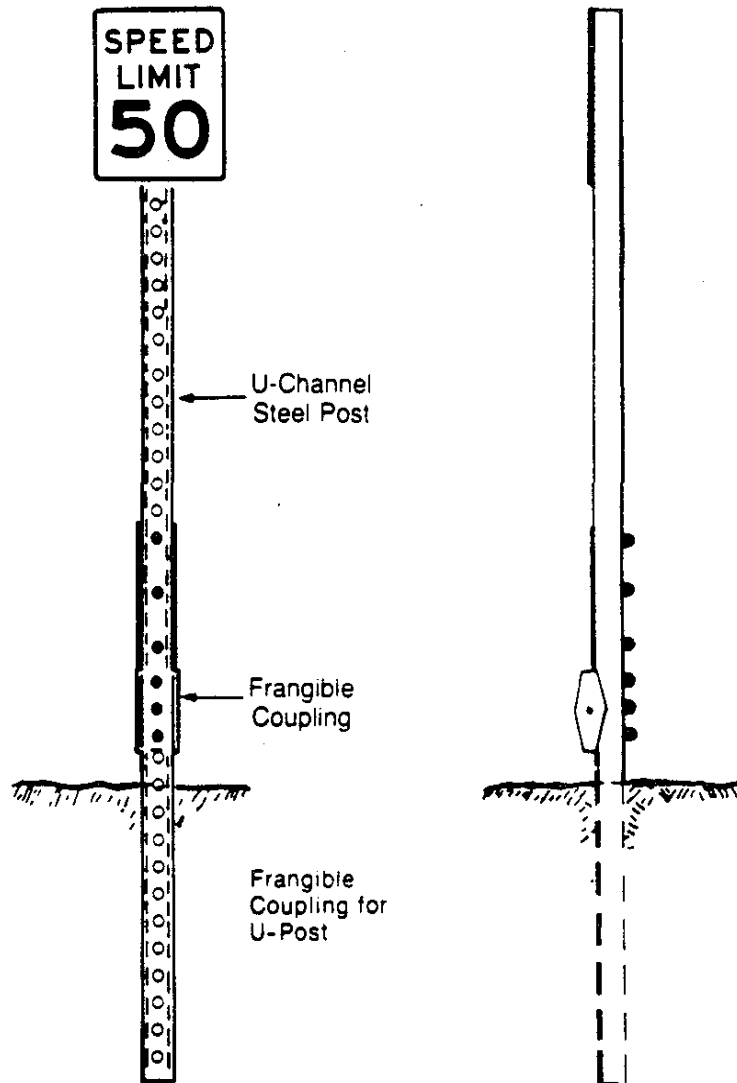

Sign Support Systems

EXAMPLES

Note: This device is used for signs with two or more posts.

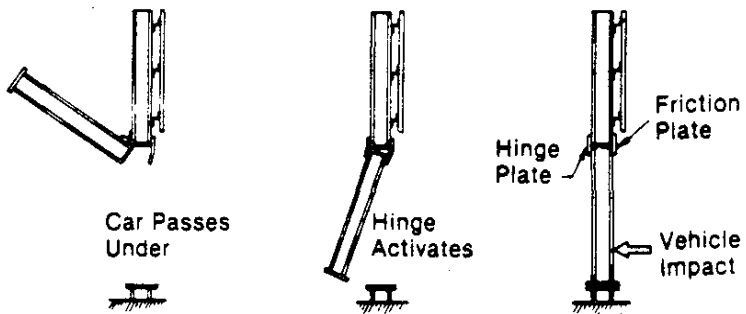

Breakaway Action—Horizontal Slip Base

Note: For use with Single Post Sign Systems

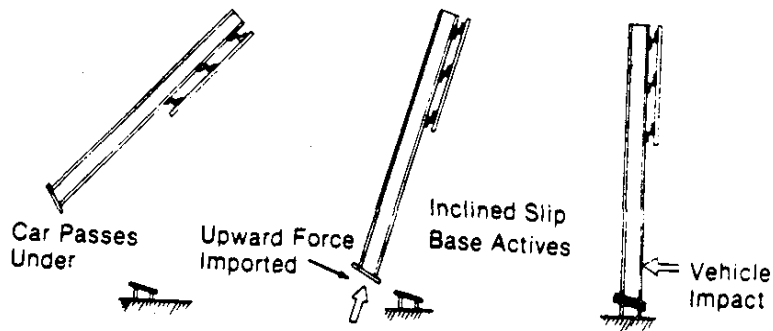

Breakaway Action—Inclined Slip Base

EXAMPLE

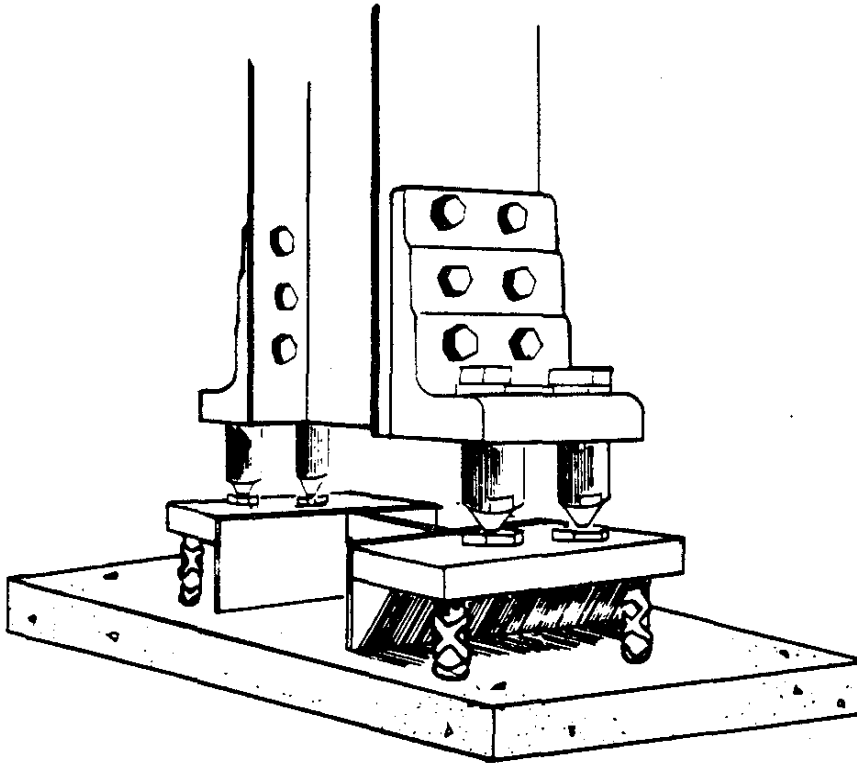
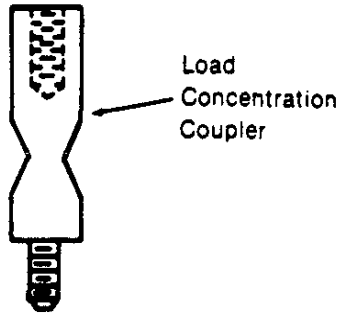

Load Concentration Coupler

6-83.20 TIMBER POST SELECTION

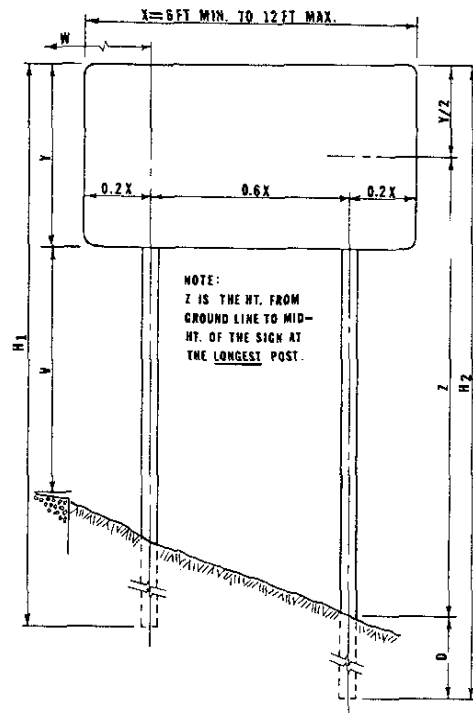
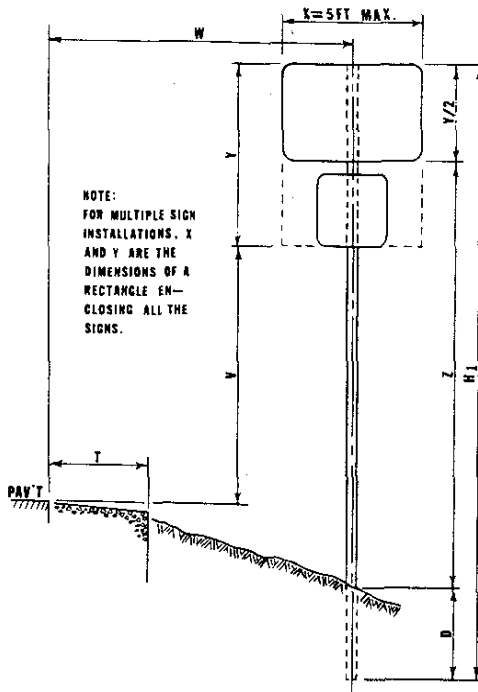

TIMBER POST SELECTION

NOTE: VALUES SHOWN ARE THE MAX. PERMITTED. IF THE QUANTITY (X)(Y)(Z) EXCEEDS THE TABLE LIMITS FOR 6"x6" POST, USE STEEL POST INSTALLATION.

CATEGORY 1, 1A, 2, 3.

POST SIZE	NO. OF POSTS			
	1	2	3	D
4 x 4	80	155	235	3'
4 x 6	180	365	545	4'
6 x 6	235	475	710	4'

() () () in FT³

DESIGN EXAMPLE

GIVEN: 2 SIGNS—ONE 3 FT WIDE, 4 FT HIGH; THE OTHER 18 INCHES WIDE, 2 FT HIGH AND MOUNTED 3 INCHES BELOW THE FIRST SIGN. $X=3'$ $Y=4'+0'-3'+2'=6'-3"$ or 6.25'. STD. MOUNTING HT. IN THIS CASE IS 5 FT: $V=5'$. 3 FT WIDE SHOULDER, WITH .05/FT SLOPE; $T=3'$. FROM EDGE OF PAVEMENT TO $\frac{1}{2}$ OF NEAREST POST IS 12 FT. $W=12'$; EMBANKMENT SLOPE IS 6:1.

SOLUTION: $Z=1/2$ HT. OF SIGN (Y) + MOUNTING HT. (V) + SHOULDER WIDTH (T) x SHOULDER SLOPE + DIST. FROM EDGE OF SHOULDER TO $\frac{1}{2}$ OF POST (W-T) x EMBANKMENT SLOPE.

$$Z = Y/2 + V + T(\text{SHOULDER SLOPE}) + (W-T)(\text{EMBANKMENT SLOPE})$$

$$Z = 6.25/2 + 5 + (3 \times .05/\text{ft}) + (12-3) \text{ at } 6:1$$

$$Z = 8.1 + .15 + 1.5 = 9.75$$

$$(X)(Y)(Z) = (3)(6.2)(9.75) = 181.4$$

ANSWER: FROM TABLE SELECT POST HAVING (X)(Y)(Z) OF 181.4 OR MORE, USE ONE 6"x6" POST.

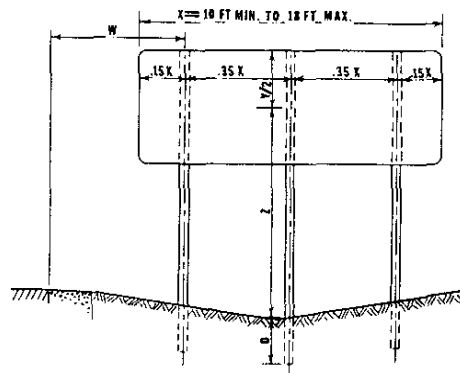

SAW CUT NOTCH FULL WIDTH OF POST, OMIT NOTCH FOR SINGLE POST INSTALLATION

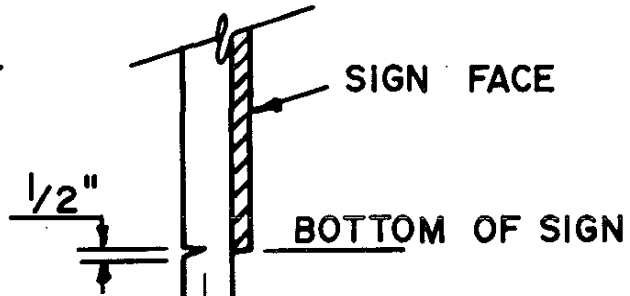

$1\ 3/4"$ NOTCH DEPTH

NOTE:

ONLY FOR 6"X6" POSTS.
HOLES & NOTCH ARE NOT REQUIRED FOR 4"X4" & 4"X6" POSTS.

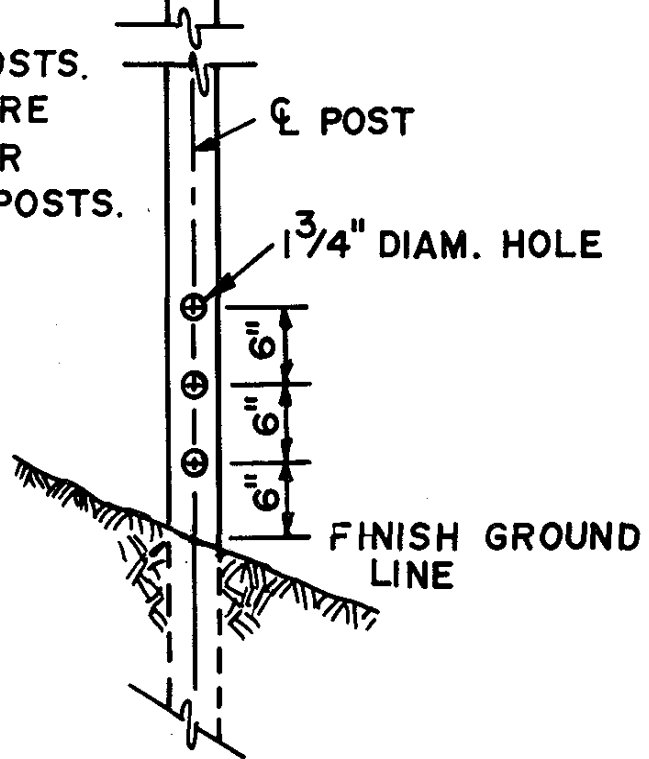

TIMBER POST DETAIL WITH BREAKAWAY

6-83.40 SIGN BRACING

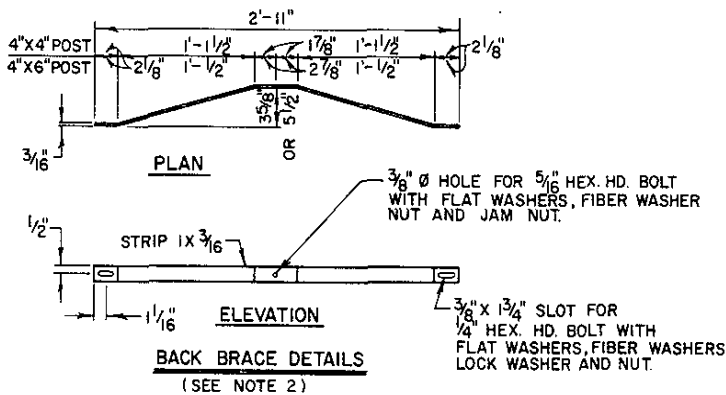
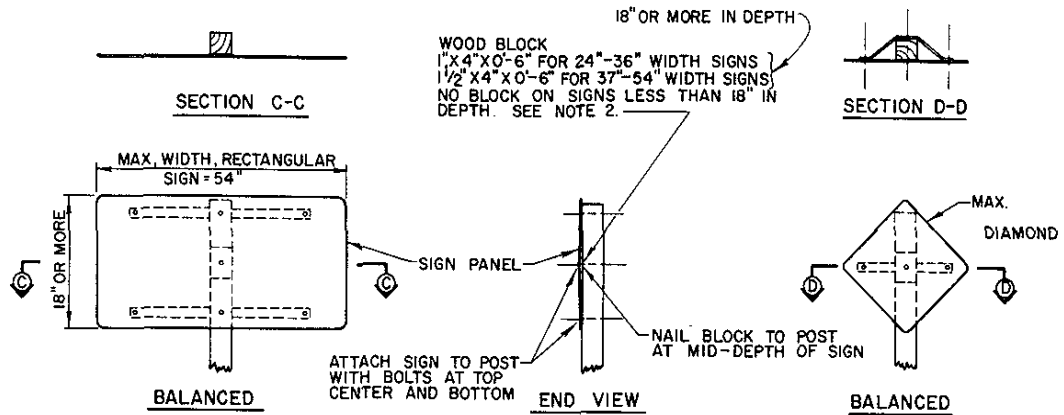

NOTES:

1. PLACE LONG DIMENSION OF POST CROSS SECTION NORMAL TO SIGN AXIS.
2. BALANCED SINGLE POST INSTALLATIONS OF UNFRAMED SINGLE SHEET ALUMINUM PANEL SIGNS SHALL HAVE BLOCKS IF 18" OR MORE IN DEPTH AND A COMBINATION OF BLOCKS AND BACK BRACES IF 18" OR MORE IN DEPTH AND 34" OR MORE IN WIDTH. SIGNS PANELS LESS THAN 18" IN DEPTH AND 34" OR MORE IN WIDTH SHALL HAVE BACK BRACES ONLY.
3. BALANCED SINGLE POST INSTALLATIONS OF LAMINATED PANEL AND FRAMED SINGLE SHEET PANEL SIGNS REQUIRE BACK BRACES WHEN 34" OR MORE IN WIDTH.

USE OF WOOD BLOCK AND BACK BRACES FOR ADDED STIFFNESS ON METAL OR WOODEN BACKED SIGNS

CHAPTER 7: PROCUREMENT OF SIGNS AND RELATED MATERIALS

The sign procurement process requires the coordinated effort of the National Park Service (NPS) and the sign manufacturer. The Park shall be the originating office in the procurement process. The Regional Sign Coordinator shall be responsible for coordinating the entire process. The process is completed with the final inspection of the finished product at the originating office. The Park shall prepare the original and necessary number of copies required by the Regional office. The Regional office will forward the original and two copies to UNICOR. If quotation is requested, UNICOR will return one copy.

By law, the National Park Service is required to order signs from UNICOR (Federal Prison Industries). All sign orders shall be processed through their offices at:

UNICOR, Data/Graphics Division
320 First Street, N.W.
Washington, D.C. 20534

The Memorandum of Agreement between the National Park Service and UNICOR outlines specific details of what is expected of each agency in an effort to enhance a better working relationship and expedite the procurement processes.

All sign orders must be machine-lettered, typewritten, or hand-printed, clearly distinguishing between upper and lower case letters, and be precise according to text, layout, and material or fabrication details.

In certain instances a waiver will be issued by UNICOR on an order which they cannot fill due to time constraints or deficiencies in supplies. Orders may, in these situations, be filled by private suppliers through the normal procurement process using the specifications in this Manual. The Regional Sign Coordinator's approval is still required before these orders may be processed.

Three tables are presented here to explain the sign procurement process, the forms to be used, and to provide an overview of the materials available. The SIGN PROCUREMENT PROCESS, Table 7-1, outlines the steps required of the Park and Regional office from preparation of the initial requisition to the eventual inspection of the finished sign product in the park upon delivery. The SIGN REQUISITION FORM USAGE, Table 7-2, explains what forms are to be used by the Park in requisitioning signs. The DESCRIPTION OF SIGN MATERIALS, Table 7-3, lists the various sign materials which can be selected, including a brief list of advantages and disadvantages for each; relative cost; and types of maintenance required.

Seven standard forms are provided for Park use in requisitioning signs. All references to the 10-84 series forms apply to the January 1984 revisions of these forms. The following is a brief description of each form.

Letters, paint, and sheeting may be obtained through UNICOR using Form DI-1.

SIGN REQUISITION FORMS

Form DI-1, United States Department of the Interior Requisition

This form shall accompany all requisitions. This form shall also be used when ordering miscellaneous signing materials such as replacement letters, NPS emblems, sheeting, sign hardware, etc.

Standard Form 147, Order for Supplies and Services

This form shall be used in preparing a purchase order to UNICOR for signs and related sign materials. Requisition forms (10-84, 10-84a, etc.) explaining the specifics of the order shall be attached to this form as necessary.

Samples of the requisition forms and Standard Form 147, and examples of these forms completely filled out are included on the following pages.

Form 10-84, Sign Requisition

This form accompanies all sign requisitions from a Park and must be signed by the requisitioner and the superintendent prior to submittal to the Regional Sign Coordinator. The Regional Sign Coordinator must sign the form prior to any sign requisition being sent to UNICOR. UNICOR will not process any orders that do not contain the Regional Sign Coordinator's signature. Space is provided on the form for additional special instructions to UNICOR from either the Park or the Regional Sign Coordinator. Should the Regional Sign Coordinator reject the order, there is space to explain why and what corrections must be made. Additional space is provided for use by UNICOR.

Form 10-84a, Guide Sign Requisition

This form shall be used for requisitioning guide signs (informational and directional), in categories 1, 1A, 2, and 3. It should be noted that all guide signs shall be manufactured using die-cut NPS Modified Clarendon letters. A separate form must be filled out for each different sign requested.

Form 10-84b, Pedestrian Sign Requisition

This form shall be used for requisitioning pedestrian guide signs, categories 4, 5, 5A, and Other. This includes signs that may require Engineering Standard letters or routed letters. A separate form is required for each different sign requested.

Form 10-84c, Recreational Symbol Requisition

This form shall be used for requisitioning Federal recreational symbols. One form shall be used for each symbol type ordered. When symbols are to be attached to another sign panel, the required number of form 10-84c's shall be attached to form 10-84a or b, whichever is appropriate.

Form 10-84d, Standard Traffic Control Signs Requisition

This form shall be used for requisitioning all standard traffic control signs as specified in the MUTCD or the Standard Highway Signs Book.

Form 10-84e, or 10-84f Custom Traffic Control Signs Requisition

This form shall be used for requisitioning all custom traffic control signs that are needed for enforcement, warning, or construction zone signing.

NOTE

**The following pages
include sign requisition
forms and examples
of how they should be
completed for submission.**

**UNITED STATES
DEPARTMENT OF THE INTERIOR
REQUISITION**

To	Bureau/Office	Requisition No.
Appropriation/Allotment No.	Charge shipping costs to	Date
Vendor	Deliver to	

ITEM OR FORM NO.	DESCRIPTION	QUANTITY	UNIT	UNIT PRICE	AMOUNT

To Be Completed by Fiscal Authority Only			
FUND CERTIFICATION: Funds in the amounts shown are available and chargeable to the cost authorities shown above.			
Signature	Date	Approved by (Signature)	Date
Title		Title	
Requisitioned by (Signature)	Date	Bureau Officer (Signature)	Date
Title		Title	

Prepare in single space typing. Use double space between items. Fill out top of requisition completely, showing complete shipping instructions and appropriation if different from that to which requisition is chargeable.

UNITED STATES
DEPARTMENT OF THE INTERIOR
REQUISITION

To		Bureau/Office	Requisition No.
<i>Procurement</i>		<i>NPS-SWRO-OM</i>	<i>2153</i>
Appropriation/Allotment No.		Charge shipping costs to	Date
<i>PX 7120 3 0025</i>		<i>Same</i>	<i>4/16/87</i>
Vendor		Deliver to	
<i>UNICOR Data/Graphics Division Washington, D.C. 20534</i>		<i>Superintendent Bandelier Nat'l Monument</i>	

ITEM OR FORM NO.	DESCRIPTION	QUANTITY	UNIT	UNIT PRICE	AMOUNT
1	<i>NPS Guide Sign as per attached form 10-84A Page 3</i>	1	<i>ea.</i>	<i>292.29</i>	<i>292.29</i>
2	<i>NPS Pedestrian Sign as per attached form 10-84B Page 4</i>	3	<i>ea.</i>	<i>57.95</i>	<i>173.85</i>
3	<i>Recreational symbol as per attached form 10-84C Page 5</i>	4	<i>ea.</i>	<i>6.00</i>	<i>24.00</i>
4	<i>Standard Highway Traffic Signs as per attached form 10-84 Page 6</i>	28	<i>b.s.</i>		<i>962.20</i>
5	<i>Custom Highway Traffic Sign as per attached form 10-84E Page 7</i>	3	<i>ea.</i>	<i>60.00</i>	<i>180.00</i>
6	<i>Custom Highway Traffic Sign as per attached form 10-84F Page 8</i>	2	<i>ea.</i>	<i>117.90</i>	<i>235.80</i>
					<i>1,868.14</i>

To Be Completed by Fiscal Authority Only			
FUND CERTIFICATION: Funds in the amounts shown are available and chargeable to the cost authorities shown above.			
Signature	Date	Approved by (Signature)	Date
		<i>Superintendent</i>	
Title		Bureau Officer (Signature)	Date
Requisitioned by (Signature)	Date		
<i>R+T Foreman</i>		<i>Regional Signs Coordinator</i>	

Prepare in single space typing. Use double space between items. Fill out top of requisition completely, showing complete shipping instructions and appropriation if different from that to which requisition is chargeable.

MARK ALL PACKAGES AND PAPERS WITH CONTRACT AND/OR ORDER NUMBERS

1. DATE OF ORDER	2. CONTRACT NO. (if any)	3. ORDER NO.	PAGE 1 OF
------------------	--------------------------	--------------	-----------

4. ISSUING OFFICE

5. ACCOUNTING AND APPROPRIATION DATA

6. SHIP TO (Consignee and Address, ZIP Code)	VIA
--	-----

7. TO: CONTRACTOR (Name, Address, ZIP Code)	8. TYPE OF ORDER (a) Purchase Reference your _____ Please furnish the following on the terms specified on both sides of this order and on the attached sheets, if any, including delivery as indicated. This purchase is negotiated under authority of _____ <input type="checkbox"/> (b) Delivery Except for billing instructions on the reverse, this delivery order is subject to instructions contained on this side only of this form and is issued subject to the terms and conditions of the above-numbered contract.
---	---

9. REQUISITION OFFICE	10. REQUISITION NO./PURCHASE AUTHORITY
-----------------------	--

11. F.O.B. POINT	12. GOVERNMENT B/L NO.	13. DELIVERY TO F.O.B. POINT ON OR BEFORE	14. DISCOUNT TERMS
------------------	------------------------	---	--------------------

15. SCHEDULE *See reverse for rejections						
Item No. (a)	Supplies or Services (b)	Quantity Ordered (c)	Unit (d)	Unit Price (e)	Amount (f)	Quantity Accepted (g)

16. CLASSIFICATION: <input type="checkbox"/> SMALL BUSINESS <input type="checkbox"/> OTHER THAN SMALL BUSINESS <input type="checkbox"/> MINORITY BUSINESS ENTERPRISE				15. (h) Total from continuation pages
SEE BILLING INSTRUCTIONS ON REVERSE	17. SHIPPING POINT	18. GROSS SHIPPING WEIGHT	19. INVOICE NO.	
20. MAIL INVOICE TO (Include ZIP Code)				15. (i) GRAND TOTAL

21. UNITED STATES OF AMERICA BY (Signature)	22. NAME (Typed) TITLE: CONTRACTING/ORDERING OFFICER
---	---

MARK ALL PACKAGES AND PAPERS WITH CONTRACT AND/OR ORDER NUMBERS

1. DATE OF ORDER April 17, 1984	2. CONTRACT NO. (if any) FPI	3. ORDER NO. PX 7120 3 0025	PAGE 8 OF 8
---	--	---------------------------------------	---------------------------

4. ISSUING OFFICE
USDI, National Park Service, Bandelier Nat'l Mon.

5. ACCOUNTING AND APPROPRIATION DATA
0670-1000-454

6. SHIP TO (Consignee and Address, ZIP Code)
**Superintendent, Bandelier Nat'l Monument
Los Alamos, New Mexico 87544**

VIA **Call Max Garcia for our pick-up**

7. TO: CONTRACTOR (Name, Address, ZIP Code) UNICOR Data / Graphics Division 320 First Street, N.W. Washington, D.C. 20534	8. TYPE OF ORDER (a) Purchase Reference your quote by Diane Please furnish the following on the terms specified on both sides of this order and on the attached sheets, if any, including delivery as indicated. This purchase is negotiated under authority of 41 USC 252 C 3 <input type="checkbox"/> (b) Delivery Except for billing instructions on the reverse, this delivery order is subject to instructions contained on this side only of this form and is issued subject to the terms and conditions of the above-numbered contract.
---	---

9. REQUISITION OFFICE Maintenance	10. REQUISITION NO. / PURCHASE AUTHORITY FY 84-017
---	--

11. F.O.B. POINT Origin	12. GOVERNMENT B / L NO. -	13. DELIVERY TO F.O.B. POINT ON OR BEFORE 20 Days	14. DISCOUNT TERMS Net
-----------------------------------	--------------------------------------	---	----------------------------------

15. SCHEDULE *See reverse for rejections

Item No. (a)	Supplies or Services (b)	Quantity Ordered (c)	Unit (d)	Unit Price (e)	Amount (f)	Quantity Accepted (g)
1	NPS Guide Sign as per attached form 10-84A page 3	1	ea	292.29	292.29	
2	NPS Pedestrian Sign as per attached form 10-84B page 4	3	ea	57.95	173.85	
3	Recreational Symbol as per attached form 10-84C page 5	4	ea	6.00	24.00	
4	Standard Highway Traffic Signs as per attached form 10-84D pg. 6	28	L.S.		962.20	
5	Custom Highway Traffic Sign as per attached form 10-84E page 7	3	ea	60.00	180.00	
6	Custom Highway Traffic Sign as per attached form 10-84F page 8	2	ea	117.90	235.80	

16. CLASSIFICATION: SMALL BUSINESS OTHER THAN SMALL BUSINESS MINORITY BUSINESS ENTERPRISE

SEE BILLING INSTRUCTIONS ON REVERSE	17. SHIPPING POINT	18. GROSS SHIPPING WEIGHT	19. INVOICE NO.	15. (h) Total from continuation pages 15. (i) GRAND TOTAL 1,868.14
	20. MAIL INVOICE TO (Include ZIP Code) Same as #6			

21. UNITED STATES OF AMERICA BY (Signature) Max Garcia	22. NAME (Typed) Max J. Garcia 505-672-3861 TITLE: CONTRACTING / ORDERING OFFICER
--	--

UNITED STATES DEPARTMENT OF THE INTERIOR
NATIONAL PARK SERVICE

FORM 10-84 REVISED JAN 1984		SIGN REQUISITION		PAGE _____ OF _____ PAGES	
PARK	<input type="checkbox"/> UNICOR Data/Graphics Division 320 First Street, N.W. Washington, D.C. 20534	PARK OR OFFICE		TOTAL NUMBER OF SIGNS	
	<input type="checkbox"/> OTHER - SPECIFY	DELIVER TO		PURCHASE ORDER NO.	
				ACCOUNT NO.	
				COST ESTIMATE	
REMARKS					
REQUISITIONED BY PARK SIGN COORDINATOR			APPROVED BY SUPERINTENDENT		QUOTATION WANTED
SIGNATURE _____ DATE _____			SIGNATURE _____ DATE _____		<input type="checkbox"/> YES <input type="checkbox"/> NO
REGIONAL SIGN COORDINATOR	REGIONAL SIGN COORDINATOR USE				
	REMARKS				
	APPROVED BY		ADDRESS AND TELEPHONE NO.		DATE
	SIGNATURE _____				PHONE NO.
<input type="checkbox"/> SIGN ORDER REJECTED BY REGIONAL SIGN COORDINATOR					
EXPLANATION			SIGNATURE		DATE
UNICOR	UNICOR USE				
	JOB NUMBER		QUOTATION NO.	ESTIMATED DELIVERY DATE	
	REMARKS				
	SIGNATURE		TITLE		DATE

UNITED STATES DEPARTMENT OF THE INTERIOR
NATIONAL PARK SERVICE

FORM 10-84
REVISED JAN 1984

SIGN REQUISITION

PAGE 2 OF 8 PAGES

UNICOR
Data/Graphics Division
320 First Street, N.W.
Washington, D.C. 20534

OTHER - SPECIFY

PARK OR OFFICE

Bandelier Nat'l Monument

DELIVER TO

*Superintendent
Bandelier Nat'l Monument
Los Alamos, NM 87544*

TOTAL NUMBER OF SIGNS

41

PURCHASE ORDER NO.

PX 7120 3 0025

ACCOUNT NO.

0670-1000-454

COST ESTIMATE

\$1,868.14

REMARKS

REQUISITIONED BY PARK SIGN COORDINATOR

Carlos Gonzales 4/16/84
SIGNATURE DATE

APPROVED BY SUPERINTENDENT

John Lissaway 4/16/84
SIGNATURE DATE

QUOTATION WANTED

YES NO

REGIONAL SIGN COORDINATOR USE

REMARKS

*Note that the signs are needed by May 25, 1984.
Please send confirmation of receipt of purchase
order for signs to Regional Sign Coordinator within
5 days of receiving P.O.*

APPROVED BY

Jack Galloway
SIGNATURE

ADDRESS AND TELEPHONE NO.

*Southwest Regional Office
P.O. Box 728
Santa Fe, NM 87501*

DATE

4/16/84

PHONE NO.

988-6368

SIGN ORDER REJECTED BY REGIONAL SIGN COORDINATOR

EXPLANATION

SIGNATURE

DATE

UNICOR USE

JOB NUMBER

QUOTATION NO.

ESTIMATED DELIVERY DATE

REMARKS

SIGNATURE

TITLE

DATE

UNITED STATES DEPARTMENT OF THE INTERIOR NATIONAL PARK SERVICE

FORM 10-84A REVISED JAN 1984		GUIDE SIGN REQUISITION (DESTINATION, DISTANCE, INFORMATION)		PAGE ____ OF ____ PAGES			
PURCHASE ORDER NO. _____		UNICOR JOB NO. _____		INVENTORY NO. (OPTIONAL) _____			
FOR ASSISTANCE CONTACT REGIONAL SIGN COORDINATOR _____				PHONE NO. _____			
USAGE CATEGORY/POSTED SPEED LIMIT/LETTER SIZE <input type="checkbox"/> OVERSIZE (12" UC - 8" LC) <input type="checkbox"/> 1 or 1A 50 - 55 MPH (9" UC - 6" LC) <input type="checkbox"/> 2 35 - 45 MPH (6" UC - 4" LC) <input type="checkbox"/> 3 0 - 30 MPH (3.75" UC - 2.5" LC)			RECREATIONAL SYMBOL(s) <div style="display: flex; justify-content: space-around; align-items: center;"> <div style="border: 1px solid black; padding: 5px; margin: 2px;">RS</div> <div style="border: 1px solid black; padding: 5px; margin: 2px;">RS</div> <div style="border: 1px solid black; padding: 5px; margin: 2px;">RS</div> <div style="border: 1px solid black; padding: 5px; margin: 2px;">RS</div> </div> <p style="font-size: small; text-align: center;">ATTACH FORM 10-84C FOR EACH SYMBOL REQUIRED</p>				
BACKING PANEL <input type="checkbox"/> .135" FRP PANEL <input type="checkbox"/> .080 ALUMINUM <input type="checkbox"/> 3/4" HDO EXT APA		ALUMINUM ZEE BACKING STIFFENERS (REQUIRED FOR ALL 32" x 48" OR LARGER) <input type="checkbox"/> YES <input type="checkbox"/> NO		LOCATION DATA AREA: _____ UNIT: _____ SIGN NO. _____			
SIGN EXAMPLE <div style="display: flex; align-items: center; justify-content: center; margin-top: 10px;"> <div style="border: 1px solid black; width: 60%; height: 60%; margin: 10px;"></div> </div> <p style="text-align: center; margin-top: 10px;">WIDTH (6" INCREMENTS)</p> <p style="text-align: center; margin-top: 10px;">HEIGHT (2" INCREMENTS)</p>							
*SPECIAL INSTRUCTIONS				ESTIMATED PER SIGN COST			
				ITEM	QTY	UNIT COST	COST
				SQUARE FOOTAGE			
				EMBLEM			
				ZEE BAR			
				ARROWS			
				LETTERS			
				SET UP			
			TOTAL				
UNICOR USE - COST			NPS USE - ESTIMATED COST				
EACH _____		TOTAL _____		EACH _____ TOTAL _____			
BY _____		DATE _____		BY _____ DATE _____			

UNITED STATES DEPARTMENT OF THE INTERIOR
NATIONAL PARK SERVICE

FORM 10-84A REVISED JAN 1984		GUIDE SIGN REQUISITION (DESTINATION, DISTANCE, INFORMATION)		PAGE <u>3</u> OF <u>8</u> PAGES																																								
PURCHASE ORDER NO PX 7120 3 0025		UNICOR JOB NO	QUANTITY 1	INVENTORY NO (OPTIONAL)																																								
FOR ASSISTANCE CONTACT REGIONAL SIGN COORDINATOR			PHONE NO. 988-6368																																									
USAGE CATEGORY/POSTED SPEED LIMIT/LETTER SIZE <input type="checkbox"/> OVERSIZE (12" UC - 8" LC) <input type="checkbox"/> 1 or 1A 50 - 55 MPH (9" UC - 6" LC) <input checked="" type="checkbox"/> 2 35 - 45 MPH (6" UC - 4" LC) <input type="checkbox"/> 3 0 - 30 MPH (3.75" UC - 2.5" LC)		RECREATIONAL SYMBOL(S) <div style="display: flex; justify-content: space-around;"> <div style="border: 1px solid black; width: 40px; height: 40px; text-align: center; line-height: 40px;">RS</div> <div style="border: 1px solid black; width: 40px; height: 40px; text-align: center; line-height: 40px;">RS</div> <div style="border: 1px solid black; width: 40px; height: 40px; text-align: center; line-height: 40px;">RS</div> <div style="border: 1px solid black; width: 40px; height: 40px; text-align: center; line-height: 40px;">RS</div> </div> ATTACH FORM 10-84C FOR EACH SYMBOL REQUIRED																																										
BACKING PANEL <input type="checkbox"/> .135" FRP PANEL <input type="checkbox"/> .080 ALUMINUM <input checked="" type="checkbox"/> 3/4" HDO EXT APA		ALUMINUM ZEE BACKING STIFFENERS <input checked="" type="checkbox"/> YES <input type="checkbox"/> NO		LOCATION DATA AREA: Bandelier N. Mon. UNIT: North Entrance SIGN NO. 00057																																								
SIGN EXAMPLE	SIGN EXAMPLE <div style="display: flex; align-items: center;"> <div style="writing-mode: vertical-rl; transform: rotate(180deg);">HEIGHT 42" (2" INCREMENTS)</div> <table border="1" style="margin-left: 20px;"> <tr> <td colspan="6" style="text-align: center;">WIDTH 84"</td> </tr> <tr> <td colspan="6" style="text-align: center;">(6" INCREMENTS)</td> </tr> <tr> <td style="text-align: center;">4.6</td> <td style="text-align: center;">34.1</td> <td style="text-align: center;">16.7</td> <td style="text-align: center;">3</td> <td style="text-align: center;">21</td> <td style="text-align: center;">4.6</td> </tr> </table> <div style="margin-left: 20px;"> <table border="1" style="writing-mode: vertical-rl; transform: rotate(180deg);"> <tr><td style="text-align: center;">4.1</td></tr> <tr><td style="text-align: center;">3.75</td></tr> <tr><td style="text-align: center;">4</td></tr> <tr><td style="text-align: center;">6</td></tr> <tr><td style="text-align: center;">4</td></tr> <tr><td style="text-align: center;">6</td></tr> <tr><td style="text-align: center;">4</td></tr> <tr><td style="text-align: center;">6</td></tr> <tr><td style="text-align: center;">4.1</td></tr> </table> </div> </div>				WIDTH 84"						(6" INCREMENTS)						4.6	34.1	16.7	3	21	4.6	4.1	3.75	4	6	4	6	4	6	4.1													
	WIDTH 84"																																											
(6" INCREMENTS)																																												
4.6	34.1	16.7	3	21	4.6																																							
4.1																																												
3.75																																												
4																																												
6																																												
4																																												
6																																												
4																																												
6																																												
4.1																																												
*SPECIAL INSTRUCTIONS <ol style="list-style-type: none"> 1. Attach 21" x 27" NPS Emblem decal where shown. 2. This is a special sign requiring both 6" and 3.75" letters. 				<table border="1" style="width:100%; border-collapse: collapse;"> <thead> <tr> <th colspan="4">ESTIMATED PER SIGN COST</th> </tr> <tr> <th>ITEM</th> <th>QTY</th> <th>UNIT COST</th> <th>COST</th> </tr> </thead> <tbody> <tr> <td>SQUARE FOOTAGE</td> <td align="right">24.5</td> <td align="right">4.20</td> <td align="right">102.90</td> </tr> <tr> <td>EMBLEM</td> <td align="right">1</td> <td></td> <td align="right">57.60</td> </tr> <tr> <td>ZEE BAR</td> <td align="right">14</td> <td align="right">3.50</td> <td align="right">49.00</td> </tr> <tr> <td>ARROWS</td> <td></td> <td></td> <td></td> </tr> <tr> <td>LETTERS 6"</td> <td align="right">25</td> <td align="right">1.53</td> <td align="right">38.25</td> </tr> <tr> <td>3.75" letters</td> <td align="right">8</td> <td align="right">1.18</td> <td align="right">9.44</td> </tr> <tr> <td>Set Up</td> <td></td> <td></td> <td align="right">35.10</td> </tr> <tr> <td colspan="3">TOTAL</td> <td align="right">292.29</td> </tr> </tbody> </table>	ESTIMATED PER SIGN COST				ITEM	QTY	UNIT COST	COST	SQUARE FOOTAGE	24.5	4.20	102.90	EMBLEM	1		57.60	ZEE BAR	14	3.50	49.00	ARROWS				LETTERS 6"	25	1.53	38.25	3.75" letters	8	1.18	9.44	Set Up			35.10	TOTAL			292.29
ESTIMATED PER SIGN COST																																												
ITEM	QTY	UNIT COST	COST																																									
SQUARE FOOTAGE	24.5	4.20	102.90																																									
EMBLEM	1		57.60																																									
ZEE BAR	14	3.50	49.00																																									
ARROWS																																												
LETTERS 6"	25	1.53	38.25																																									
3.75" letters	8	1.18	9.44																																									
Set Up			35.10																																									
TOTAL			292.29																																									
UNICOR USE - COST EACH _____ TOTAL _____ BY _____ DATE _____		NPS USE - ESTIMATED COST EACH \$ 292.29 TOTAL \$ 292.29 BY UG DATE 4/14/84																																										







UNITED STATES DEPARTMENT OF THE INTERIOR NATIONAL PARK SERVICE

FORM-1084B REVISED JAN 1982		PEDESTRIAN SIGN REQUISITION		PAGE _____ OF _____ PAGES			
PURCHASE ORDER NO. _____		UNICOR JOB NO. _____		QUANTITY _____	INVENTORY NO. (OPTIONAL) _____		
FOR ASSISTANCE CONTACT REGIONAL SIGN COORDINATOR: _____ PHONE NO. _____							
USAGE CAT.	<input type="checkbox"/> 4 2.25" UC 1.5" LC CLARENDON (DIE CUT OR ROUTED)		<input type="checkbox"/> 1.0" UC ENGINEERING STANDARD (ROUTED)		RECREATIONAL SYMBOLS <input type="checkbox"/> RS <input type="checkbox"/> RS <input type="checkbox"/> RS <input type="checkbox"/> RS ATTACH FORM 10-84C FOR SYMBOL REQUIRED		
	<input type="checkbox"/> 5 1.5" UC 1.0" LC CLARENDON (DIE CUT OR ROUTED)		<input type="checkbox"/> 3/4" UC ENGINEERING STANDARD (ROUTED)				
	<input type="checkbox"/> 5A 1.0" UC .67" LC CLARENDON (ROUTED)		<input type="checkbox"/> 1/2" UC ENGINEERING STANDARD (ROUTED)				
LOCATION DATA AREA: _____ UNIT: _____ SIGN NO: _____							
STANDARD SIGNS	BACKING PANEL <input type="checkbox"/> .080" ALUMINUM <input type="checkbox"/> 3/4" HDO EXT APA <input type="checkbox"/> .135" FRP		BACKGROUND FINISH <input type="checkbox"/> REFLECTIVE BROWN <input type="checkbox"/> OTHER *SPECIFY BELOW <input type="checkbox"/> ANODIZED BROWN FACE <input type="checkbox"/> PLAIN ALUMINUM FACE		LETTER STYLE - SIZE CLARENDON DIE CUT (CAT. 4, 5) ENGINEERING STANDARD (ROUTED) <input type="checkbox"/> CLARENDON ROUTED <input type="checkbox"/> ENGINEERING STD. ROUTED		
	LETTER FINISH <input type="checkbox"/> REFLECTIVE WHITE <input type="checkbox"/> OTHER *SPECIFY BELOW PAINT <input type="checkbox"/> BROWN <input type="checkbox"/> OTHER <input type="checkbox"/> WHITE *SPECIFY BELOW		ROUTED SIGNS	PAINTED FACE *SPECIFY BELOW <input type="checkbox"/> STAIN <input type="checkbox"/> OTHER <input type="checkbox"/> NATURAL W/ SEALER *SPECIFY BELOW <input type="checkbox"/> PAINT		ENGINEERING STD ROUTED <input type="checkbox"/> CLARENDON ROUTED <input type="checkbox"/> ENGINEERING STD. ROUTED <input type="checkbox"/> ENGINEERING STD ROUTED	
250" ALUMINUM PLATE 3/4" HDO EXT APA WOOD *SPECIFY BELOW		STAIN <input type="checkbox"/> OTHER NATURAL W/ SEALER *SPECIFY BELOW PAINT		STAIN <input type="checkbox"/> OTHER NATURAL W/ SEALER *SPECIFY BELOW PAINT			
SIGN EXAMPLE <div style="display: flex; align-items: center;"> <div style="margin-right: 20px;"> HEIGHT 2" INCREMENTS </div> <div style="border: 1px solid black; width: 600px; height: 150px; margin: 0 auto;"></div> <div style="margin-left: 20px;"> WIDTH 6" INCREMENTS (FOR CLARENDON LETTERS ONLY) </div> </div>							
NOTE: BORDER OPTIONAL FOR ROUTED SIGNS							
SPECIAL INSTRUCTIONS				ESTIMATED PER SIGN COST			
				ITEM	QTY	UNIT COST	COST
				SQUARE FOOTAGE			
				EMBLEM			
				ARROWS			
				LETTERS			
				SET UP			
				TOTAL			
UNICOR USE - COST EACH _____ TOTAL _____ BY _____ DATE _____			NPS USE - ESTIMATED COST EACH _____ TOTAL _____ BY _____ DATE _____				





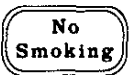

**UNITED STATES DEPARTMENT OF THE INTERIOR
NATIONAL PARK SERVICE**

FORM-1084B REVISED JAN 1982		PEDESTRIAN SIGN REQUISITION		PAGE <u>4</u> OF <u>8</u> PAGES		
PURCHASE ORDER NO. PX 7120 3 0025		UNICOR JOB NO.	QUANTITY 3	INVENTORY NO. (OPTIONAL)		
FOR ASSISTANCE CONTACT REGIONAL SIGN COORDINATOR: Jack Galloway			PHONE NO. 988-1368			
USAGE CAT.	<input checked="" type="checkbox"/> 4 2.25" UC 1.5" LC CLARENDON (DIE CUT OR ROUTED)	<input type="checkbox"/> 1.0" UC ENGINEERING STANDARD (ROUTED)	RECREATIONAL SYMBOLS RS RS RS RS		LOCATION DATA AREA Bandelier N.M.	
	<input type="checkbox"/> 5 1.5" UC 1.0" LC CLARENDON (DIE CUT OR ROUTED)	<input type="checkbox"/> ¾" UC ENGINEERING STANDARD (ROUTED)	ATTACH FORM TO-84C FOR SYMBOL REQUIRED		UNIT: North Ext. Sta.	
<input type="checkbox"/> 5A 1.0" UC .67" LC CLARENDON (ROUTED)	<input type="checkbox"/> ½" UC ENGINEERING STANDARD (ROUTED)			SIGN NO: 00052		
STANDARD SIGNS	BACKING PANEL <input type="checkbox"/> .080" ALUMINUM	BACKGROUND FINISH <input checked="" type="checkbox"/> REFLECTIVE BROWN	LETTER SYTLE / SIZE CLARENDON DIE CUT (CAT. 4 5)		LETTER FINISH <input checked="" type="checkbox"/> REFLECTIVE WHITE	
	<input type="checkbox"/> ¾" HDO EXT APA	<input type="checkbox"/> OTHER *SPECIFY BELOW			<input type="checkbox"/> OTHER *SPECIFY BELOW	
ROUTED SIGNS	<input checked="" type="checkbox"/> .135" FRP	<input type="checkbox"/> ANODIZED BROWN FACE	ENGINEERING STANDARD (ROUTED)		PAINT <input type="checkbox"/> BROWN <input type="checkbox"/> OTHER	
	<input type="checkbox"/> .250" ALUMINUM PLATE	<input type="checkbox"/> PLAIN ALUMINUM FACE	<input type="checkbox"/> CLARENDON ROUTED		<input type="checkbox"/> WHITE *SPECIFY BELOW	
	<input type="checkbox"/> ¾" HDO EXT APA	PAINTED FACE *SPECIFY BELOW	<input type="checkbox"/> ENGINEERING STD. ROUTED			
	<input type="checkbox"/> WOOD *SPECIFY BELOW	<input type="checkbox"/> STAIN <input type="checkbox"/> OTHER	<input type="checkbox"/> CLARENDON ROUTED		<input type="checkbox"/> STAIN <input type="checkbox"/> OTHER	
		<input type="checkbox"/> NATURAL W/ SEALER *SPECIFY BELOW	<input type="checkbox"/> ENGINEERING STD ROUTED		<input type="checkbox"/> NATURAL W SEALER *SPECIFY BELOW	
		<input type="checkbox"/> PAINT			<input type="checkbox"/> PAINT	
SIGN EXAMPLE	SIGN EXAMPLE		WIDTH 18"			
			6" INCREMENTS (FOR CLARENDON LETTERS ONLY)			
	HEIGHT 10"	2" INCREMENTS				
NOTE: BORDER OPTIONAL FOR ROUTED SIGNS						
SPECIAL INSTRUCTIONS 1. Attach reflective border as per NPS Sign Manual Specifications.			ESTIMATED PER SIGN COST			
			ITEM	QTY	UNIT COST	COST
			SQUARE FOOTAGE	125	4.20	525
			EMBLEM			
			ARROWS			
			LETTERS			
			1.5" letters	23	.90	2070
			Set Up			32.00
			SET UP			
			TOTAL		59.95	
UNICOR USE - COST			NPS USE - ESTIMATED COST			
EACH _____	TOTAL _____		EACH \$ 59.95	TOTAL _____		
BY _____	DATE _____		BY JG	DATE _____		

UNITED STATES DEPARTMENT OF THE INTERIOR
NATIONAL PARK SERVICE

FORM 10-84C REVISED JAN 1984		RECREATIONAL SYMBOL REQUISITION			PAGE ____ OF ____ PAGES	
PURCHASE ORDER NO. _____		UNICOR JOB NO. _____	QUANTITY _____	INVENTORY NO. (OPTIONAL) _____		
FOR ASSISTANCE CONTACT REGIONAL SIGN COORDINATOR _____				PHONE NO. _____		
TRAFFIC SIGNS	USAGE CATEGORY / POSTED SPEED <input type="checkbox"/> OPTIONAL 1. 1A <input type="checkbox"/> 1.1A 50-55 MPH <input type="checkbox"/> 2 35-45 MPH	BASIC SYMBOL ONLY  <input type="checkbox"/> 24 x 24 <input type="checkbox"/> 18 x 18 <input type="checkbox"/> 12 x 12	WITH PROHIBITIVE SLASH  <input type="checkbox"/> 24 x 24 <input type="checkbox"/> 18 x 18 <input type="checkbox"/> 12 x 12	WITH SECONDARY SYMBOL  <input type="checkbox"/> 24 x 36 <input type="checkbox"/> 18 x 28 1/2 <input type="checkbox"/> 12 x 18 1/2	ARROW PLAQUE  <input type="checkbox"/> 12 x 12 <input type="checkbox"/> 8 x 8	TEXT PLAQUE * SPECIFY BELOW  <input type="checkbox"/> 8 x 24 <input type="checkbox"/> 6 x 18 <input type="checkbox"/> 4 x 12
	<input type="checkbox"/> 4 <input type="checkbox"/> 5 <input type="checkbox"/> 5A	<input type="checkbox"/> 8 x 8 <input type="checkbox"/> 6 x 6	<input type="checkbox"/> 8 x 8 <input type="checkbox"/> 6 x 6		<input type="checkbox"/> 4 x 4	<input type="checkbox"/> 3 x 8 <input type="checkbox"/> 3 x 6
BACKING PANEL <input type="checkbox"/> .080 ALUMINUM <input type="checkbox"/> .135" FRP PANEL <input type="checkbox"/> 3/4" HDO EXT APA <input type="checkbox"/> FACE SHEETING ONLY						
RECREATIONAL SYMBOL NO. RS _____		PROHIBITIVE SLASH <input type="checkbox"/> YES <input type="checkbox"/> NO	FOR USE ON ANOTHER SIGN <input type="checkbox"/> YES <input type="checkbox"/> NO	INVENTORY NO. (OPTIONAL) _____		
ARROW	DIRECTION <input type="checkbox"/>  <input type="checkbox"/> 					
TEXT	WORDING: _____ WORDING INCLUDES: DISTANCES AND PROHIBITIVE TEXT. TEXT TO EXPLAIN THE SYMBOL SHOULD NOT BE USED.					
SECONDARY SYMBOL	SECONDARY SYMBOL PLATE <input type="checkbox"/> YES <input type="checkbox"/> NO	RECREATIONAL SYMBOL NO. RS _____				
SPECIAL INSTRUCTIONS				NPS ESTIMATED COST EACH _____ TOTAL _____ BY _____ DATE _____		
				UNICOR COST EACH _____ TOTAL _____ BY _____ DATE _____		

UNITED STATES DEPARTMENT OF THE INTERIOR
NATIONAL PARK SERVICE

FORM 10-84C REVISED JAN 1984		RECREATIONAL SYMBOL REQUISITION		PAGE <u>5</u> OF <u>8</u> PAGES		
PURCHASE ORDER NO. PX 7120 3 0025		UNICOR JOB NO.	QUANTITY 4	INVENTORY NO. (OPTIONAL)		
FOR ASSISTANCE CONTACT REGIONAL SIGN COORDINATOR Jack Galloway PHONE NO. 988-6368						
TRAFFIC SIGNS	USAGE CATEGORY / POSTED SPEED	BASIC SYMBOL ONLY	WITH PROHIBITIVE SLASH	WITH SECONDARY SYMBOL	ARROW PLAQUE	TEXT PLAQUE * SPECIFY BELOW
	<input type="checkbox"/> OPTIONAL 1, 1A <input type="checkbox"/> 1.1A 50-55 MPH <input type="checkbox"/> 2 35-45 MPH	 <input type="checkbox"/> 24 x 24 <input type="checkbox"/> 18 x 18 <input type="checkbox"/> 12 x 12	 <input type="checkbox"/> 24 x 24 <input type="checkbox"/> 18 x 18 <input type="checkbox"/> 12 x 12	 <input type="checkbox"/> 24 x 36 <input type="checkbox"/> 18 x 28½ <input type="checkbox"/> 12 x 18½	 <input type="checkbox"/> 12 x 12 <input type="checkbox"/> 8 x 8	 <input type="checkbox"/> 8 x 24 <input type="checkbox"/> 6 x 18 <input type="checkbox"/> 4 x 12
PEDESTRIAN SIGNS	<input checked="" type="checkbox"/> 4 <input type="checkbox"/> 5 <input type="checkbox"/> 5A	<input checked="" type="checkbox"/> 8 x 8 <input type="checkbox"/> 6 x 6	<input type="checkbox"/> 8 x 8 <input type="checkbox"/> 6 x 6		<input type="checkbox"/> 4 x 4	<input type="checkbox"/> 3 x 8 <input type="checkbox"/> 3 x 6
	BACKING PANEL <input type="checkbox"/> .080 ALUMINUM <input type="checkbox"/> .135" FRP PANEL <input checked="" type="checkbox"/> ¾" HDO EXT APA <input type="checkbox"/> FACE SHEETING ONLY					
RECREATIONAL SYMBOL NO. RS 068		PROHIBITIVE SLASH <input type="checkbox"/> YES <input checked="" type="checkbox"/> NO	FOR USE ON ANOTHER SIGN <input type="checkbox"/> YES <input checked="" type="checkbox"/> NO	INVENTORY NO. (OPTIONAL)		
ARROW	DIRECTION <input type="checkbox"/>  <input type="checkbox"/> 					
TEXT	WORDING: <hr/> WORDING INCLUDES: DISTANCES AND PROHIBITIVE TEXT. TEXT TO EXPLAIN THE SYMBOL SHOULD NOT BE USED.					
SECONDARY SYMBOL	SECONDARY SYMBOL PLATE <input type="checkbox"/> YES <input checked="" type="checkbox"/> NO	RECREATIONAL SYMBOL NO. RS _____				
SPECIAL INSTRUCTIONS				NPS ESTIMATED COST EACH <u>6.00</u> TOTAL <u>24.00</u> BY <u>JG</u> DATE <u>4/16/84</u>		
				UNICOR COST EACH _____ TOTAL _____ BY _____ DATE _____		

UNITED STATES DEPARTMENT OF THE INTERIOR
NATIONAL PARK SERVICE

Form 10-84D (Jan 1984)		STANDARD HIGHWAY TRAFFIC SIGN REQUISITION			PAGE	OF
Purchase Order No.		UNICOR Job No.		NPS Area		
For Assistance Contact Regional Sign Coordinator				Phone No.		

ITEM	STANDARD ORDER CODE	SIZE	MUTCD/REMARKS CODE	QUAN	PRICE	
					EACH	TOTAL

UNITED STATES DEPARTMENT OF THE INTERIOR
NATIONAL PARK SERVICE

Form 10-84D (Jan 1984)	STANDARD HIGHWAY TRAFFIC SIGN REQUISITION	PAGE <u>6</u> OF <u>8</u>				
Purchase Order No. <u>PX 7120 3 0025</u>	UNICOR Job No.	NPS Area <u>Bandelier Nat'l Monument</u>				
For Assistance Contact Regional Sign Coordinator <u>JACK Galloway</u>		Phone No. <u>988-6368</u>				
ITEM	STANDARD ORDER CODE	SIZE	MUTCD/REMARKS CODE	QUAN	PRICE	
					EACH	TOTAL
<u>1</u>	<u>R2-1</u>	<u>18" x 24"</u>	<u>Speed Limit 25</u> <u>FP-85-TYPE III</u>	<u>6</u>	<u>30.30</u>	<u>181.80</u>
<u>2</u>	<u>R2-1</u>	<u>18" x 24"</u>	<u>Speed Limit 35</u> <u>FP-85-TYPE III</u>	<u>3</u>	<u>30.30</u>	<u>90.90</u>
<u>3</u>	<u>R2-1</u>	<u>30" x 30"</u>	<u>Yield</u> <u>FP-85 - Type III</u>	<u>3</u>	<u>41.70</u>	<u>125.10</u>
<u>4</u>	<u>R1-1</u>	<u>24" x 24"</u>	<u>Stop</u> <u>FP-85 - Type III</u>	<u>8</u>	<u>40.25</u>	<u>322.00</u>
<u>5</u>	<u>R4-7a</u>	<u>18" x 24"</u>	<u>Keep Right</u> <u>FP-85 - TYPE III</u>	<u>8</u>	<u>30.30</u>	<u>242.40</u>
						<u>962.20</u>

UNITED STATES DEPARTMENT OF THE INTERIOR
NATIONAL PARK SERVICE

Form 10-84E (Jan 1984)	CUSTOM HIGHWAY TRAFFIC SIGN REQUISITION	PAGE ____ OF ____
---------------------------	---	-------------------

Purchase Order No.	UNICOR Job No.	NPS Area
--------------------	----------------	----------

For Assistance Contact
Regional Sign Coordinator _____ Phone No. _____

ITEM	SIZE	LETTER SIZE BY LINE	LEGEND BY LINE	COLORS/ REMARKS	QUAN	PRICE EACH	TOTAL

UNITED STATES DEPARTMENT OF THE INTERIOR
NATIONAL PARK SERVICE

Form 10-84E
(Jan 1984)

CUSTOM HIGHWAY TRAFFIC SIGN REQUISITION

PAGE 7 OF 8

Purchase Order No.
PX 7120 3 0025

UNICOR Job No.

NPS Area Bandelier Nat'l Mon.

For Assistance Contact
Regional Sign Coordinator Jack Galloway

Phone No. 988-6368

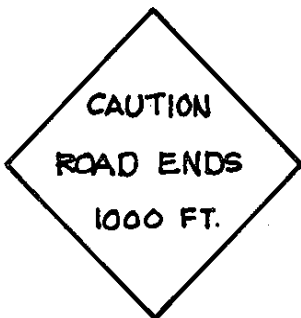
ITEM	SIZE	LETTER SIZE BY LINE	LEGEND BY LINE	COLORS/ REMARKS	QUAN	PRICE	
						EACH	TOTAL
1	24" x 24"	4"		Black on Yellow Sign No. 00081 Engineering Grade Reflective letters, border, and background 3/4" HDO Backing	3	60.00	180.00

**UNITED STATES DEPARTMENT OF THE INTERIOR
NATIONAL PARK SERVICE**

FORM 1084F		CUSTOM HIGHWAY TRAFFIC SIGN REQUISITION		PAGE ____ OF ____ PAGES			
PURCHASE ORDER NO.		UNICOR JOB NO.	QUANTITY	INVENTORY NO. (OPTIONAL)			
FOR ASSISTANCE CONTACT REGIONAL SIGN COORDINATOR:				PHONE NO. _____			
ENGINEERING STANDARD LETTER SIZE <input type="checkbox"/> 2" <input type="checkbox"/> 5" <input type="checkbox"/> 8" <input type="checkbox"/> 3" <input type="checkbox"/> 6" <input type="checkbox"/> 4" <input type="checkbox"/> 7"		RECREATIONAL SYMBOLS <div style="display: flex; justify-content: space-around;"> <div style="border: 1px solid black; padding: 2px; text-align: center;">RS</div> <div style="border: 1px solid black; padding: 2px; text-align: center;">RS</div> <div style="border: 1px solid black; padding: 2px; text-align: center;">RS</div> <div style="border: 1px solid black; padding: 2px; text-align: center;">RS</div> </div> ATTACH FORM 1084C FOR EACH REQUIRED		LOCATION DATA AREA: _____ UNIT: _____ SIGN NO: _____			
BACKING PANEL <input type="checkbox"/> .080 ALUMINUM <input type="checkbox"/> ¼" HDO EXT APA <input type="checkbox"/> .135" FRP PANEL		ALUMINUM ZEE BACKING STIFFENERS <input type="checkbox"/> YES <input type="checkbox"/> NO	REFLECTIVITY: <input type="checkbox"/> ENGINEERING GRADE (FP. 85-TYPE II) <input type="checkbox"/> HIGH INTENSITY (FP. 85-TYPE III)		COLORS: 		
SIGN EXAMPLE							
SPECIAL INSTRUCTIONS				ESTIMATED PER SIGN COST			
				ITEM	QTY	UNIT COST	COST
				SQUARE FOOTAGE			
UNICOR USE - COST			NPS USE - ESTIMATED COST				
EACH _____ TOTAL _____			EACH _____ TOTAL _____				
BY _____ DATE _____			BY _____ DATE _____				

UNITED STATES DEPARTMENT OF THE INTERIOR
NATIONAL PARK SERVICE

FORM 1084F		CUSTOM HIGHWAY TRAFFIC SIGN REQUISITION	PAGE <u>8</u> OF <u>8</u> PAGES		
PURCHASE ORDER NO. <u>PX 7120 3 0025</u>		UNICOR JOB NO.	QUANTITY <u>2</u>		
FOR ASSISTANCE CONTACT REGIONAL SIGN COORDINATOR: <u>Jack Galloway</u>		PHONE NO. <u>900-6368</u>			
ENGINEERING STANDARD LETTER SIZE <input type="checkbox"/> 2" <input type="checkbox"/> 5" <input type="checkbox"/> 8" <input type="checkbox"/> 3" <input checked="" type="checkbox"/> 6" <input type="checkbox"/> <input checked="" type="checkbox"/> 4" <input type="checkbox"/> 7" <input type="checkbox"/>	RECREATIONAL SYMBOLS <input type="checkbox"/> RS <input type="checkbox"/> RS <input type="checkbox"/> RS <input type="checkbox"/> RS ATTACH FORM 1084C FOR EACH REQUIRED	LOCATION DATA AREA: <u>Bandelier Nat'l Mon.</u> UNIT: <u>U.S. HWY 4</u> SIGN NO: <u>00051</u>			
BACKING PANEL <input type="checkbox"/> .080 ALUMINUM <input checked="" type="checkbox"/> 1/4" HDO EXT APA	ALUMINUM ZEE BACKING STIFFENERS <input type="checkbox"/> YES <input checked="" type="checkbox"/> NO	REFLECTIVITY: <input type="checkbox"/> NON REFLECTIVE <input checked="" type="checkbox"/> ENGINEERING GRADE <input type="checkbox"/> HIGH INTENSITY	COLORS: <u>White on Brown</u>		
SIGN EXAMPLE					
SPECIAL INSTRUCTIONS <u>1. Apply standard border.</u> <u>2. Adjust horizontal dimension if required for legend text.</u>		ESTIMATED PER SIGN COST			
		ITEM	QTY	UNIT COST	COST
		SQUARE FOOTAGE	<u>4</u>	<u>4.20</u>	<u>16.80</u>
		<u>6" letters</u>	<u>12</u>	<u>1.00</u>	<u>12.00</u>
		<u>4" letters</u>	<u>36</u>	<u>1.50</u>	<u>54.00</u>
		<u>set up</u>			<u>35.10</u>
		TOTAL			<u>117.90</u>
UNICOR USE - COST		NPS USE - ESTIMATED COST			
EACH _____	TOTAL _____	EACH <u>\$117.90</u>	TOTAL <u>\$235.80</u>		
BY _____	DATE _____	BY <u>JG</u>	DATE <u>4/16/84</u>		

Bureau _____

REQUISITION
(Continuation Sheet)

Bureau No. _____

ITEM OR FORM NO.	DESCRIPTION	QUAN	UNIT	UNIT PRICE	AMOUNT

TABLE 7-1
SIGN PROCUREMENT PROCESS

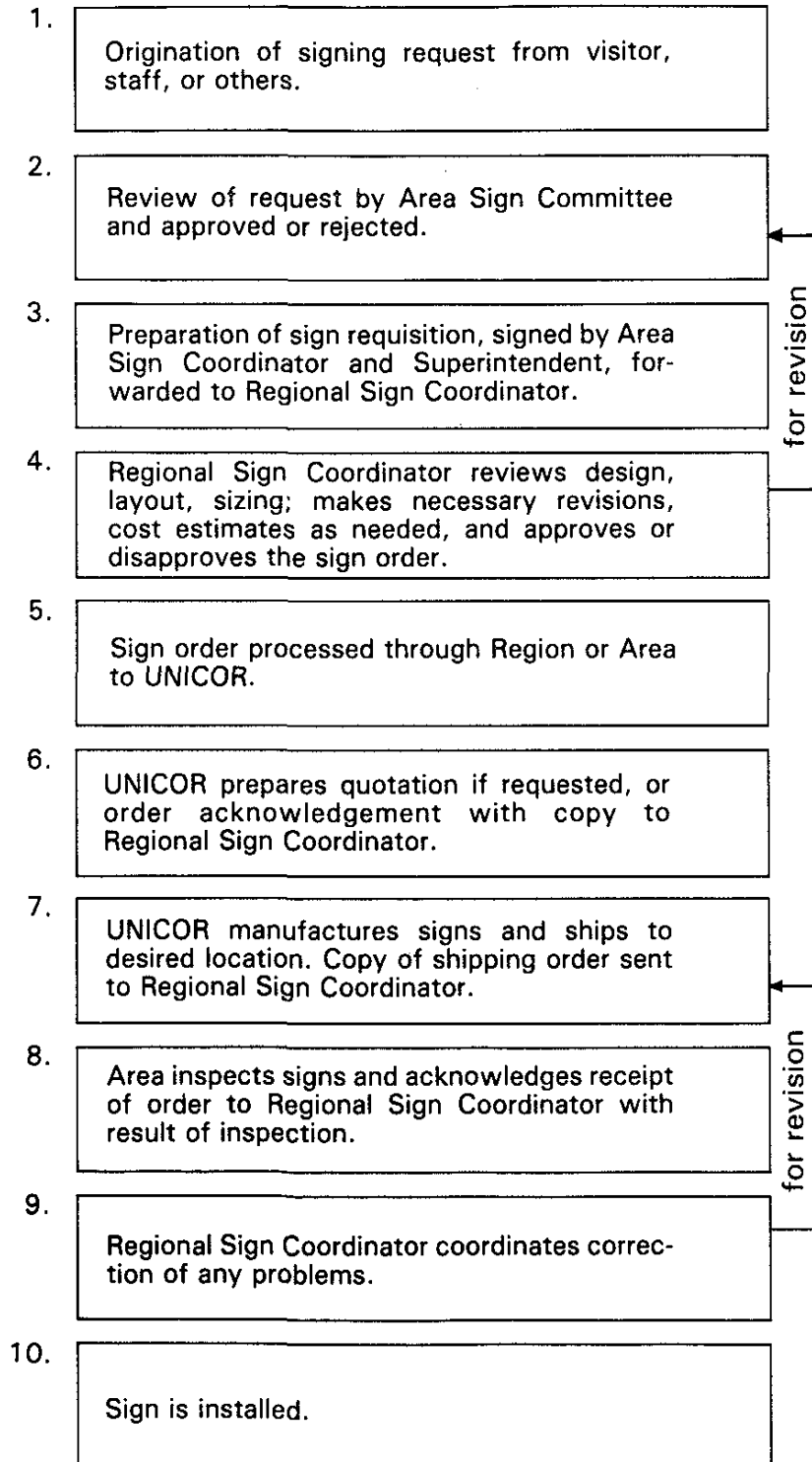

TABLE 7-2

SIGN REQUISITION FORM USAGE

Sign Type and Related Materials	Form	Remarks
Regulatory, Warning and Construction Signs	10-84D	For standard signs only as shown in the MUTCD or STD. HWY SIGN Book.
	10-84E	For custom traffic control signs not found above.
Guide Informational Signs	10-84A	For signs using NPS modified clarendon lettering. Each sign on separate sheet; recreational symbol signs on separate form.
	10-84F	For custom highway guide signs not using NPS Modified Clarendon lettering.
Pedestrian Signs	10-84B	Each sign on separate sheet, includes signs using Engineering Standard letters and routed signs.
Federal Recreation Symbols	10-84C	Each symbol on separate sheet.
Standard Entrance Signs	10-84A	Entrance signs using die-cut NPS Modified Clarendon letters.
Interpretive Signs	DI-1	Signs not designed using this Manual shall be ordered on Form DI-1 through Harpers Ferry Center.
NPS Arrowhead Emblem	DI-1	Includes silk screened and wood routed arrowheads.
Steel Stanchions	DI-1	Breakaway posts required when erected within 30' of roadway unless protected.
Wood Stanchions	DI-1	Must meet requirements of this Manual for breakaway design.

TABLE 7-2

SIGN REQUISITION FORM USAGE CON'T

Sign Type and Related Materials	Form	Remarks
Letters	DI-1	Die-cut letters for repair of existing signs. UNICOR carries supply.
Paint	DI-1	<i>For repairing signs, painting sign backs or stanchions.</i> UNICOR carries supply.
Sign Repair Kits	DI-1	UNICOR stocks various materials, and kits are available for field repair of various types of signs.
All sign orders	DI-1 and 10-84	Both forms must accompany all sign orders.
NPS Protection and Regulation Signs	DI-1	For standard 10-Series signs only, as shown in Chapter 4.

TABLE 7-3

DESCRIPTION OF SIGNING MATERIALS

Materials	Advantages/ Disadvantages	Required Maintenance
1 Reflective Sheeting on HDO Plywood	Reflective sheeting lasts longer on plywood than aluminum. Difficult to repair bullet holes.	Washing as per maintenance guidelines. Edge band top for snow protection.
2 Reflective Sheeting on Aluminum Plate	Aluminum plate lasts longer than plywood; also can be recycled.	Washing as per maintenance guidelines. Edge band top for snow protection.
3 Reflective Sheeting on RP/C backing (polyplate)	Integral color. Bullet holes simpler to repair. New material but appears to have good features.	Washing as per maintenance guidelines. Edge band top for snow protection.
4 Paint on HDO Plywood	HDO surface must be sanded before painting. Paint deteriorates, peels and repair is labor intensive.	Scraping and painting as needed.
5 Paint on Aluminum Plate	Same as 3 above but more difficult to repair.	
6 Paint on Wood	Same as 3 above.	
7 Weathering Steel Stanchions 2" x 2" 2½" x 4" 4" x 6"	Small supplies difficult to find. Require little maintenance. Holds sign better than wood. Rust streaks will form around base over time. Complicated breakaway installation.	Periodic structural stabilizing required.
8 Wood Stanchions	Supplies easier to find. Less expensive. More maintenance required. Shorter life than steel or aluminum. Best if pressure treated; untreated tend to rot at base.	Periodic staining or painting and bolt tightening (may be left natural).

TABLE 7-3

DESCRIPTION OF SIGNING MATERIALS CON'T

Materials	Advantages/ Disadvantages	Required Maintenance
9 U-Channel Steel Stanchions	Less expensive than other metal posts. May be bent over by vandals or heavy snow-plowing. Has precut mounting holes.	Periodic painting. Inspection of base coupling.
10 Square perforated steel tubing 2" x 2"	Stronger than U-Channel. Has precut mounting holes on four sides.	Periodic staining or painting and bolt tightening (may be left natural).
11 Aluminum Backing Stiffeners	Superior to wood.	If painted will require scraping and repainting.
12 Hardware for Sign mounting (bolt, 2 washers and nut)	Vandal proof is superior to standard. Zinc chromate plated steel minimizes rusting.	Periodic inspection.
13 Modified Clarendon letter, Die-Cut 1½" uc 2¼" uc 3¾" uc 6" uc 9" uc	Die-cut require less maintenance than routed letters. Replacements available.	Periodic washing, inspection and replacement.
14 Natural wood sealer	Attractive on native woods	Periodic inspection.
15 Wood stain	Do not use on HDO plywood. Color selection critical. Less maintenance than paint	Periodic inspection.
16 Wood routed 1½" uc 2¼" uc 3 x ¾" uc 6" uc 9" uc	1½" minimum size for Mod Clarendon text feasible on wood. 1" available for Engineering standard letters on HDO Plywood.	Periodic inspection.

TABLE 7-3

DESCRIPTION OF SIGNING MATERIALS

Materials	Advantages/ Disadvantages	Required Maintenance
17 Polysilicone paint	Seals surface. Increased costs and delivery time. Limited availability	
18 Aluminum 6061	Standard available.	
19 Aluminum 5052 (option)	Weaker, less rigid. Harder to work with. Less costly from commercial sign shops.	
20 Aluminum thickness .080" .125"	Standard More rigid, but more costly	

APPENDIX A
NPS MODIFIED
CLARENDON ALPHABET

A B C D E F G H I J K -

L M N O P Q R S T U V

W X Y Z a b c d e f g h

i j k l m n o p q r s t u !

v w x y z : ; " ' () & ?

1 2 3 4 5 6 7 8 9

0 \$ ¢ %

ENGINEERING STANDARD
ALPHABET

A B C D E F G H I J K
L M N O P Q R S T U V
W X Y Z a b c d e f g h
i j k l m n o p q r s t u !
v w x y z : ; " ' () & ?

1 2 3 4 5 6 7 8 9
0 \$ ¢ %

Appendix B

OUTLINE

Park Sign Plan

The following is a general outline that can be used in the preparation of an park sign plan. Certain portions of the outline may not be applicable depending on the type of park involved (i.e. historic, recreational, wilderness, parkways, etc.). An example of an approved park sign plan is included. This example plan has been abbreviated for the purpose of inclusion in this Manual.

I. *Descriptive Material*

The Park General Management Plan and Interpretive Prospecter should be referenced as they relate to this section.

- A. Description of Park
 - 1. Purpose
 - 2. Objectives
 - 3. Characteristics
 - a. Topographic
 - b. Landscape
- B. Scope of Sign Plan
 - 1. Describe sign usage categories
 - 2. Describe safety considerations
- C. Park Resources
- D. Available Public Facilities
- E. Statistics
 - 1. Regional
 - a. Local, State, National, International use
 - b. Is park the destination
 - c. Regional Highway use
 - 1. Traffic flow chart
 - 2. Travel time from populated areas
 - d. Zone of influence population
 - e. Vehicular population
 - f. Boat population
 - g. Recreational vehicle population
 - 2. Park Visitor
 - a. Nationalby month
 - b. Internationalby month
 - c. Annual curve
 - d. Miles of park roads and trails
 - e. Quantity vehicle parking
 - f. Duration of visit

- g. Breakdown of park usage of month, i.e., picnicking, camping, boating, fishing, sightseeing, educational, off-road vehicle, cross-county skiing, hiking, etc.
- 3. Group Use
- 4. Educational Groups
 - a. Age range
 - b. Grade range
 - c. Size
- 5. Park Logo
 - a. Design
 - b. Usage
 - c. Placement on sign

II. *Sign Survey and Inventory*

The sign survey and inventory establishes the effectiveness of existing signing, location, and condition. This is the first and most important process in preparing a functional sign plan.

- A. Quality, Quantity, and Categories
 - 1. Information
 - 2. Identification
 - 3. Directional
 - 4. Traffic Control
- B. Vehicular Signage
- C. Pedestrian Signage
- D. Entrance Signage
 - 1. Scope
 - 2. Purpose
 - 3. Function
 - 4. Do they reflect the true purpose and significance of the park?
- E. Interpretive Signs and Wayside Exhibits
 - 1. Purpose
 - 2. Function
 - 3. Motif
 - a. Outside facility
 - b. Facility
- G. NPS Route Markers
- H. Trail Markers
- I. NPS Protection and Regulation Signage

III. *Location Plan*

The location plan should include various drawings which indicate where all signs are located, their orientation and message. These drawings are a continuing planning device to assist in determining *what is said with signs, what should be said, and where it is said.*

A. Existing

1. Message
2. Direction of Face
3. Inventory Number
4. Photographs

B. Proposed

1. Message
2. Direction of Face

C. Vandalism Prone Signs

IV. *Summary*

General description of sign plan function within Park and how it is integrated into park management, safety, and operational practices.

APPENDIX C
SAMPLE SIGN PLAN

PIPESTONE NATIONAL MONUMENT

SIGN PLAN

June, 1981

I. *Descriptive Material*

A. Description of Monument

1. Description: Pipestone National Monument, an area of 281.78 acres, is located in southwestern Minnesota adjacent to the city of Pipestone. The area preserves the noted Pipestone (catlinite - an unusual red stone) Quarries in their natural virgin prairie setting.
2. Function: The purpose of Pipestone National Monument is twofold: to preserve and manage the ethnological, historical, archeological, and geological resources of the area for the betterment and enjoyment of all; and to manage the pipestone quarries so as to provide the American Indian with free access to the pipestone to quarry, fashion, and carve from it the articles relating to his culture.
3. Objectives:
 - a. To preserve and protect the ethnological and historical resources of Pipestone National Monument in a manner that assures their continued integrity.
 - b. To perpetuate and protect the natural resources of Pipestone National Monument, including the virgin prairie, Lake Hiawatha, Pipestone Creek, and the woodland environments, in a manner which minimizes, to the greatest extent possible, disturbances of natural processes, except where necessary to ensure the continuation of quarrying activities. The virgin prairie and Pipestone Creek will be managed as cultural as well as natural resources.
 - c. To foster appreciation and understanding of the traditions and handicrafts of the Upper Midwest Indians, primarily those of the plains and woodland tribes, and their contributions to America's cultural heritage.
 - d. To cooperate with State and local government agencies, private groups and individuals, adjacent landowners, and members of the public, in preserving and perpetuating the cultural and natural resources of the Monument; in ensuring that developments and activities in the vicinity of the Monument are compatible with the area's purpose; and in ensuring the availability of adequate information and services for the visiting public.
 - e. To cooperate and maintain close liaison with American Indian groups and individuals who actively support or engage in area programs, including onsite handicraft demonstrations and quarrying activities, to ensure compliance with the legislative mandate, compatibility with other park objectives, and a harmonious relationship with the Indian people.
 - f. To ensure the availability of appropriate developments for area administration, visitor use, and cultural activities, including facilities which support the operation of the Upper Midwest Cultural Center and the quarries, at the highest standard possible for the safety and protection of visitors and employees, and in a manner consistent with resource management objectives.

- g. To encourage and participate in efforts to acquire information and data on the historical and archeological resources, the quarrying operations, and the natural resources of Pipestone National Monument, through research and other means, in order to facilitate development of the best possible strategies for (1) preserving and managing the cultural resources, in particular, the catlinite quarries, (2) perpetuating and restoring the prairie and other natural resources, and (3) enhancing opportunities for resource-compatible public use and enjoyment.
4. Characteristics: The Monument is gently rolling land in a portion of a shallow glacial valley. The natural resource base of Pipestone National Monument consists basically of tall grass prairie. The prairie is bisected in a north-south line by the 15-foot high quartzite outcrop in the eastern quarter and by the Pipestone Quarry line near the middle of the Monument. Trees and shrubs are common along these two areas giving certain portions of the park a forested appearance. Pipestone Creek bisects the area from east to west in approximately the middle of the park and forms a 12-foot falls as it goes over the quartzite ledge and also forms a small lake near the quarry line.

B. Scope of Sign Plan

1. Description: The overall purpose of the Sign Plan at Pipestone National Monument is to provide for the systematic and uniform upkeep of the sign system. This is to be achieved by complying with the guidelines, rules and procedures set forth in the "Manual on Uniform Traffic Control Devices (MUTCD)" and further supplemented by the "National Park Service Sign Manual".

The specific purpose of the Pipestone National Monument Sign Plan is to provide a system of signs which will:

- a. Inform visitor how and where to enter the Monument.
 - b. Safely route arriving visitors to the Monument's designated parking areas.
 - c. Guide him/her to areas that will provide basic orientation and interpretive information about the Monument's environmental and historical resources and facilities.
 - d. Warn and inform the visitor so his/her visit will be as safe and enjoyable as possible.
 - e. Provide for a safe and understandable exit from trail and Visitor Center to parking area where he can get further information and depart the Monument.
2. Identification: The sign system is comprised of four categories identified and treated as follows:
 - a. Entrance signs - These signs inform the visitor that they have entered the Monument. At present there are two entrance signs in the Monument and there is no need for more. Both signs are of routed pine and have orange lettering on a brown background.
 - b. Vehicular signs - There are very few vehicular signs in the Monument because the entrance road is so short. The signs that are necessary on the road and in the parking lot will conform to MUTCD standards and the NPS Sign Manual.

- c. Interpretive/Informative signs - This is the largest category of signs. All signs in this group inform the visitor on facilities and areas open to them or the signs interpret the Monument's features on the trail. Most of these signs are made of routed pine, with orange lettering on a brown background.
 - d. Pedestrian signs - This category includes all directional and warning signs located throughout the Monument meant to be viewed by pedestrians. The signs are routed pine with orange letters on a brown background.
- C. Park Resources: The primary resource of the Monument, the one for which it was established, is to preserve the noted Pipestone (catlinite - an unusual red stone) Quarries in their natural virgin prairie setting. American Indians have obtained stone from the noted quarries for centuries to make pipes for ceremonial and social use, making the Monument an area of ethnological, archeological and historical significance.

There are 42 active quarries and a number of old, inactive quarries in the Monument. The pipestone layer is sandwiched between harder layers of Sioux quartzite and the top layer must be removed before the pipestone can be reached. Pipestone is also found in other areas but has only been quarried extensively here.

The natural history of the area is rich in Indian lore and legends. Most of the 282 acres of the Monument is virgin prairie with the balance in vegetated woodland, creek bottom lands, and the Quartzite ledge. Because there is such a diversity of habitats, the Monument abounds with birds in a great variety. Some species that occur are several ducks, woodpeckers and ring-necked pheasants. Mammals in the Monument include white-tailed deer, beaver, muskrat, fox and other small species. Pipestone Creek which runs through the park contains suckers, northern pike, sunfish, bullheads and bass. There are also painted and snapping turtles and at least one variety of salamander.

Historic features are limited and consist mostly of sites with no surface remains. Such features are the Indian campsites and old quarrying pits.

- D. Available Public Facilities: The Monument facilities are comprised of: Visitor Center/Cultural Center with a slide presentation, a sales display area, and live cultural demonstrations of pipemaking and other crafts; 60-car parking lot; self-guiding paved trail to points of interest in the park; and a picnic area with facilities that can handle up to 70 picnickers. Camping is not allowed in the park.

In the surrounding Pipestone, Minnesota area there are many city parks with good picnicking facilities. Private and public campgrounds are available and within a 30-minute drive are three state parks and one large county park, all with picnicking and camping facilities.

Public transportation into the area is not good; an estimated 90% of the visitors arrive by private automobile. Most towns in the area are small and agriculture-oriented; therefore, accommodations are not too plentiful.

E. Statistics

1. Regional: The Monument is located in Pipestone County, Minnesota. The

MONTHLY VISITATION PATTERNS
1979 - MAY, 1981

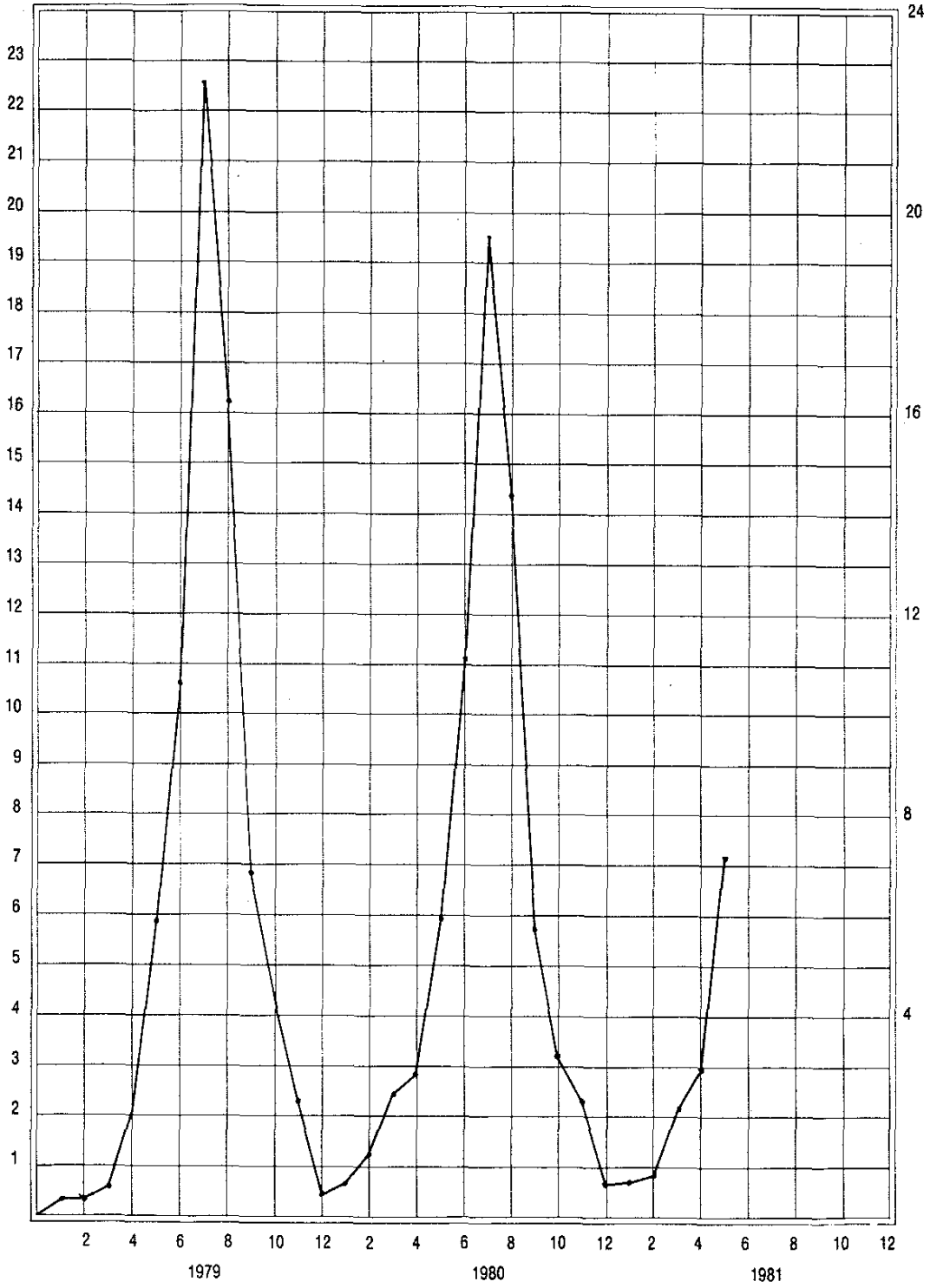

county has a total population of 12,000. Within 150 miles of Pipestone, the major centers of population are:

Mankato, MN	31,000
Marshall, MN	11,000
Worthington, MN	11,000
St. Cloud, MN	42,000
Sioux Falls, SD	72,000
Brookings, SD	18,000
Ft. Dodge, IA	31,000
Sioux City, IA	85,000

The large regional urban areas of Minneapolis-St. Paul, Omaha-Council Bluffs and Des Moines are in the 200-250 mile radius.

The total population within the 200-mile radius of the Monument is 2.5 million in five states: Minnesota, Iowa, Nebraska, North Dakota and South Dakota.

The people who influence the Monument are in a 5-mile radius. Since the Monument is located on the north limits of the city of Pipestone, management decisions often have an effect on the community. Conversely, events within the community influence Monument management.

2. **Park Visitor:** The Monument is usually not a destination, although visitor use has increased steadily over the years. Visitors representing every State utilize the Monument and this widening of the radius of the use area continues to increase with the completion of I-90. Visitation peaked in 1976 and has been steady since. Early 1981 reports show that visitation is up 23% from last year and is also above the 1976 total for the same time period. The typical visitor to the Monument spends 2-3 hours, visits the museum, views the slide show and walks the self-guiding trail.
3. **Group Use:** The Monument has two basic types of tour groups--school (organized) and commercial (senior citizen and other) that visit the site. School group tours take place predominately in the Spring. Senior citizen and other commercial tours are usually scheduled so they will coincide with the annual showing of the Hiawatha Pageant, located on the south boundary of the Monument.
4. **Educational Groups:** School groups comprise the majority of educational use visitors, represent all age groups, and for the most part visit the Monument in April or May. The usual group size is 35-40. Virtually all school groups visit the Monument as their intended destination.
5. **Park Logo:** No distinctive park logo has been designed for the Pipestone National Monument nor is one recommended. The number of signs on which such a logo could be justifiably utilized is minimal.

II. *Sign Survey and Inventory*

- A. **Quality, Quantity and Categories:** The attached sheets (Part II) provide a complete inventory of all the in-place signs found in the Pipestone National Monument Sign System. Most signs that are in the Monument are made by maintenance staff when required for replacement.

All signs are in good to excellent condition and if not, they will be replaced promptly. The quantity of signs by category is as follows:

Information	24
Interpretation	23
Regulatory	10
Warning	3
Entrance	2
NPS Emblem	2
Total	<hr/> 64

- B. Interpretive Signs and Wayside Exhibits: The Monument currently has one wayside/interpretive exhibit located on the southern boundary beside the picnic grounds. This exhibit tells the legend of the "Three Maidens" who are supposedly lying beneath five large, granite boulders located next to the exhibit.
- Various other interpretive signs, largely identifying nature and Indian legends, along with a taped presentation (exhibit quarry), help to facilitate the visitor conducting a self-guided walking tour of the Monument.
- C. Advertisement Signage: Directional signs have been provided on Interstate 90 by the Minnesota Dept. of Transportation. The City of Pipestone provides directional markers at most main highway junctions in town.
- D. Trail Markers: The trail at Pipestone National Monument is basically self-guiding. Visitors may choose whether to follow the trail marker arrows or pick up a Circle Trail guide booklet at the front desk.
- E. NPS Protection and Regulation: The use of protection and regulation signage, other than traffic control, is limited within the historic site, but important. The two warning signs in the Monument are set at strategic locations beside quarries where the visitors could slip and injure themselves on the loose, rocked, steep-sided quarries.

III. Location Plan

A total of 64 signs, as depicted on the Monument's sign location plan (page 9), currently comprise the in-place sign system for the historic site. The sign messages are as found on the Sign Survey and Inventory sheets and the sign photographs. Since almost all signs are made as needed, none are kept in storage.

IV. Summary

The Pipestone National Monument's existing sign system is consistent in carrying out the objectives of the historical site while at the same time complying with the MUTCD and NPS Sign Manual.

This sign plan will have no adverse effects on archeological resources within the historic site. Any modification of ground surfaces during project implementation will be properly monitored for the presence of archeological remains. The Superintendent will be promptly notified if any do occur.

The signage in conjunction with the self-guiding folder is relied upon to properly orient, motivate and safely move the visitor throughout the site and at the same time provide proper interpretation for a safe, enjoyable visit at Pipestone National Monument.

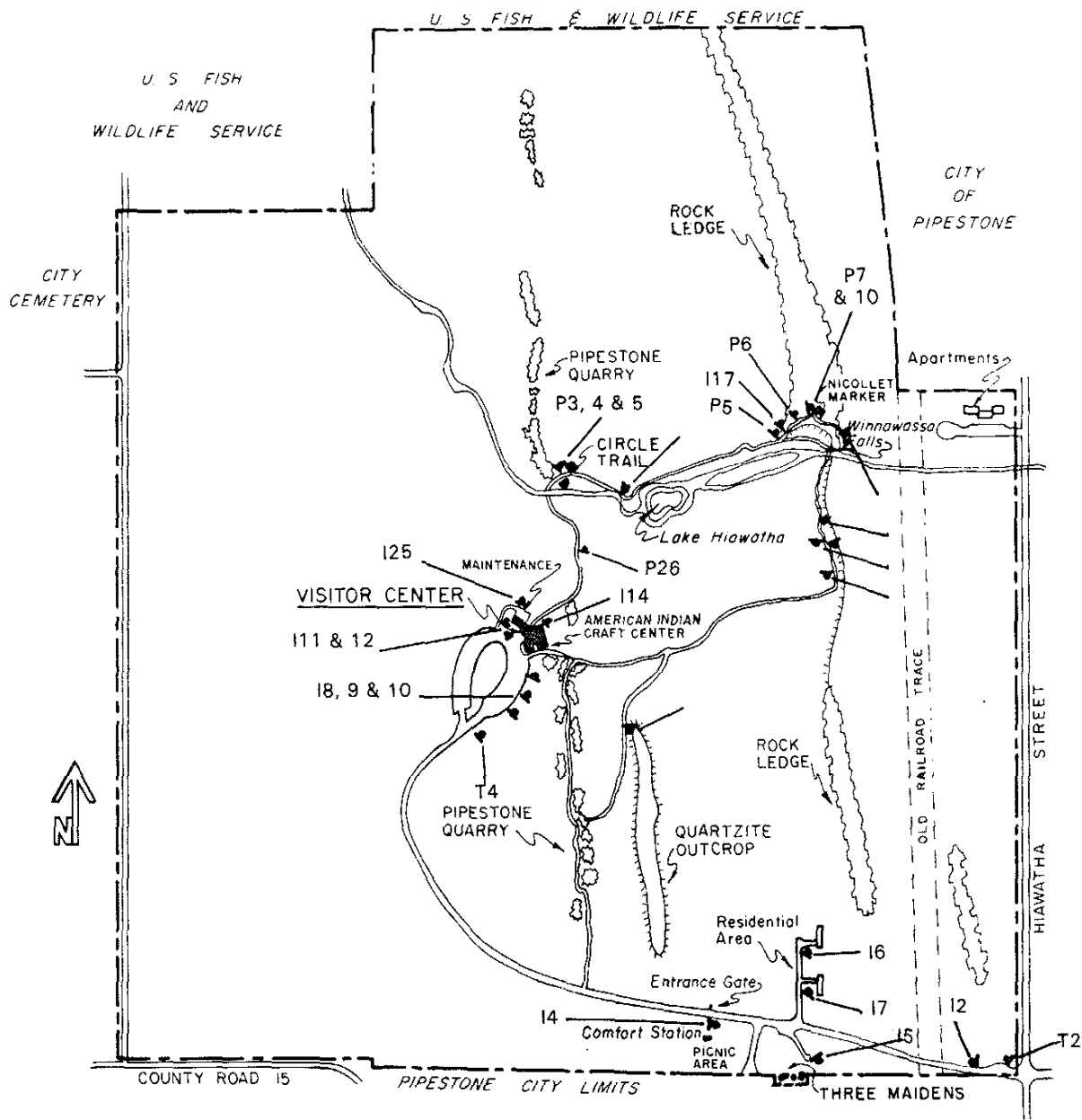

0 200 400 800
SCALE IN FEET (APPROX.)

NOTE.
ALL LAND WITHIN NPS BOUNDARY IS IN HISTORIC ZONE.
----- NPS BOUNDARY

STATEMENT FOR MANAGEMENT
EXISTING MANAGEMENT ZONING and BOUNDARY MAP

PIPESTONE NATIONAL MONUMENT
PIPESTONE COUNTY, MINNESOTA

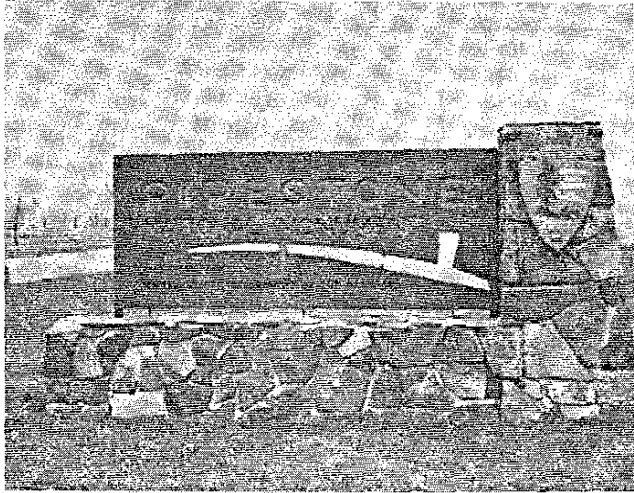

E-1, I-1



E-7



T-1

C-8

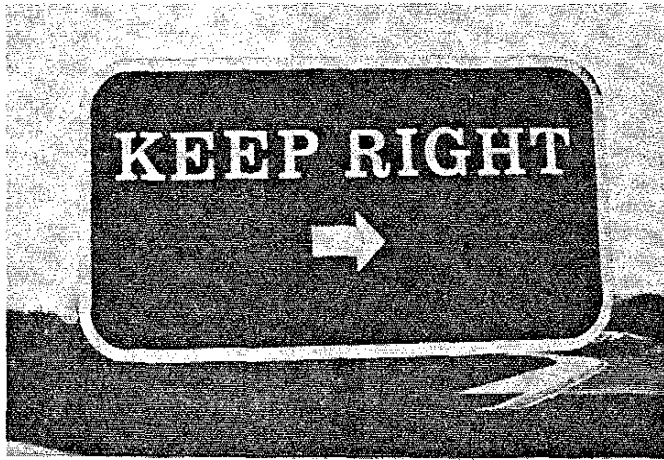

T - 3

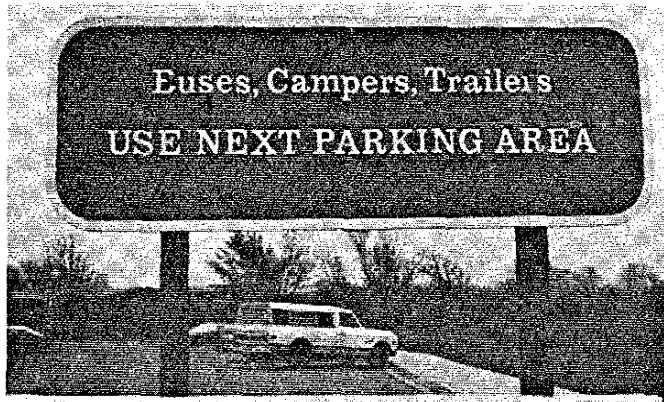

T - 4



T - 2



P - 1



P - 2, P - 6,
P - 7, P - 8

- S I G N P L A N -

PIPESTONE NATIONAL MONUMENT

PIPESTONE, MINNESOTA

RECOMMENDED: (Sgd).David L. Lane
Superintendent, Pipestone National Monument

RECOMMENDED: (Sgd).Dan L. Wilson
Regional Sign Coordinator

CONCURRED: (Sgd).Ralph G. Dierks
Chief, Maintenance

CONCURRED: (Sgd).John Kawamoto
Associate Regional Director,
Planning and Resource Preservation

APPROVED: (Sgd).J. T. Dunning
Regional Director, Midwest Region

APPENDIX D

Specifications for STANDARD HIGHWAY SIGN COLORS

This Data Sheet has been prepared by the Federal Highway Administration for the convenience of users and manufacturers of highway signs and to promote uniformity in sign colors. The Manual on Uniform Traffic Control Devices,¹ in sections 1A-8 and 2A-11, prescribe the color code for general meanings and color combinations for various classifications of highway signs. This sheet defines the six primary colors and specifies the tolerance for each color.

These Specifications for highway sign colors yellow, red, blue, green, brown, and orange have been taken from the Federal Highway Administration Color Tolerance Charts,² which contain color chips for each limit and the central color. The charts are designed to permit visual comparison of a sample with the standard colors.

PR Color #1 HIGHWAY YELLOW-13538*						
LIMIT	CIE DATA FOR SOURCE C			MUNSELL NOTATION		
	Y	x	y	H	V C	
Central	50.68	.5007	.4555	10YR	7.5/14	
Value+	59.10	.4940	.4530	10YR	8.0/14	
Value-	36.20	.5137	.4602	10YR	6.5/14	
Hue+	50.68	.4920	.4705	2.0Y	7.5/14	
Hue-	50.68	.5065	.4445	8.5YR	7.5/14	
Chroma+	50.68	.5133	.4631	10YR	7.5/16	
Chroma-	50.68	.4826	.4447	10YR	7.5/12	

PR Color #4 HIGHWAY GREEN-14109*						
LIMIT	CIE DATA FOR SOURCE C			MUNSELL NOTATION		
	Y	x	y	H	V C	
Central	6.56	.2088	.4101	7.5G	3.00/8	
Value+	10.43	.1942	.4228	7.5G	3.75/10	
Value-	3.82	.1904	.4208	7.5G	2.25/8	
Hue+	6.56	.1943	.3779	0.5BG	3.00/8	
Hue-	6.56	.2228	.4380	5.0G	3.00/8	
Chroma+	6.56	.1800	.4310	7.5G	3.00/10	
Chroma-	6.56	.2346	.3901	7.5G	3.00/6	

PR Color #2 HIGHWAY RED-11105*						
LIMIT	CIE DATA FOR SOURCE C			MUNSELL NOTATION		
	Y	x	y	H	V C	
Central	9.00	.6003	.3146	7.0R	3.5/13	
Value+	12.00	.5738	.3262	7.0R	4.0/13	
Value-	6.56	.6268	.3030	7.0R	3.0/13	
Hue+	9.00	.5928	.3235	8.0R	3.5/13	
Hue-	9.00	.5915	.3065	6.0R	3.5/13	
Chroma+	9.00	.6330	.3045	7.0R	3.5/15	
Chroma-	9.00	.5835	.3185	7.0R	3.5/12	

PR Color #5 HIGHWAY BROWN**						
LIMIT	CIE DATA FOR SOURCE C			MUNSELL NOTATION		
	Y	x	y	H	V C	
Central	5.52	.4766	.3816	5YR	2.75/5	
Value+	7.71	.4608	.3801	5YR	3.25/5	
Value-	3.81	.4955	.3826	5YR	2.25/5	
Hue+	5.52	.4762	.3981	7.0YR	2.75/5	
Hue-	5.52	.4728	.3607	2.5YR	2.75/5	
Chroma+	5.52	.5081	.3912	5YR	2.75/6	
Chroma-	5.52	.4450	.3720	5YR	2.75/4	

PR Color #3 HIGHWAY BLUE-15090*						
LIMIT	CIE DATA FOR SOURCE C			MUNSELL NOTATION		
	Y	x	y	H	V C	
Central	6.56	.1780	.1833	2.5PB	3.0/8	
Value+	9.00	.1887	.1963	2.5PB	3.5/8	
Value-	3.13	.1540	.1530	2.5PB	2.0/8	
Hue+	6.56	.1908	.1799	5.0PB	3.0/8	
Hue-	6.56	.1658	.1905	10B	3.0/8	
Chroma+	6.56	.1576	.1600	2.5PB	3.0/10	
Chroma-	6.56	.2022	.2101	2.5PB	3.0/6	

PR Color #6 HIGHWAY ORANGE***						
LIMIT	CIE DATA FOR SOURCE C			MUNSELL NOTATION		
	Y	x	y	H	V C	
Central	24.58	.5609	.3950	2.5YR	5.5/14	
Value+	30.05	.5488	.3947	2.5YR	6.0/14	
Value-	19.77	.5731	.3953	2.5YR	5.0/14	
Hue+	24.58	.5570	.4072	3.75YR	5.5/14	
Hue-	24.58	.5614	.3815	1.25YR	5.5/14	
Chroma+	24.58	.5713	.3970	2.5YR	5.5/15	
Chroma-	24.58	.5348	.3898	2.5YR	5.5/12	

- * Color number in Federal Standard 595a meeting this specification.
- ** ISCC-NBS color designation 56-strong brown approximates this specification.
- *** ISCC-NBS color designation 48-vivid orange approximates this specification.

1. *Manual on Uniform Traffic Control Devices for Streets and Highways*, 1978 edition, Federal Highway Administration. For sale by the Superintendent of Documents, U.S. Government Printing Office, Washington, D.C., 20402. Stock No. 050-001-90001-7. Price \$18.00 including subscription service for future changes.
2. *Color Tolerance Charts*, PR Colors 1-4 (June 1965), Colors 5-6 (March 1971), Federal Highway Administration, contact the Federal Highway Administration, Washington, D.C., 20590 for availability information.

May 1979

BTO-21

DOT/FHWA

APPENDIX E

This space provided for Manual holders to use for inserting current UNICOR price information, listing manufacturer's catalog data, and frequently called phone numbers.