

Historic Furnishings Report

**EL CASTILLO DE SAN CRISTOBAL**

SAN JUAN  
National Historic Site/Puerto Rico

ON MICROFILM

Color Scans  
12/5/2002

PLEASE RETURN TO:  
TECHNICAL INFORMATION CENTER  
DENVER SERVICE CENTER  
NATIONAL PARK SERVICE

U.S. Department of the Interior/National Park Service

HISTORIC FURNISHINGS REPORT

EL CASTILLO DE SAN CRISTÓBAL

San Juan National Historic Site  
San Juan, Puerto Rico

Prepared by  
José Ignacio Avellaneda, Ph. D.  
Historian

Under contract for  
National Park Service  
Harpers Ferry Center  
Division of Historic Furnishings  
1993

## Contents

ACKNOWLEDGEMENTS .....	iv
ADMINISTRATIVE DATA .....	1
INTERPRETIVE OBJECTIVES .....	1
OPERATING PLAN .....	2
106 COMPLIANCE .....	3
PRIOR PLANNING DOCUMENTS .....	3
HISTORICAL DATA .....	5
HISTORY OF SAN CRISTÓBAL CASTLE .....	5
THE SPANISH FORCES OF 18th CENTURY PUERTO RICO .....	6
HISTORICAL OCCUPANCY .....	15
EVIDENCE OF FURNISHINGS .....	17
Evidence for Specific Rooms .....	19
Latrines .....	19
Kitchens .....	22
Guardhouses .....	27
Troops' Quarters .....	30
Officers' Quarters .....	32
Evidence of Uniform, Equipment, and Furniture .....	33
Mess Rooms .....	34
FURNISHING PLAN .....	35
WORKING DRAWINGS OF TROOPS' QUARTERS .....	36
RECOMMENDED FURNISHINGS .....	38
Troops' Quarters .....	38
WORKING DRAWINGS OF GUARDHOUSE .....	40
RECOMMENDED FURNISHINGS .....	42
Guardhouse at the North Casemates .....	42
FURNISHINGS MAINTENANCE AND PROTECTION RECOMMENDATIONS AND PROCEDURES .....	43
NOTES .....	45
ILLUSTRATIONS .....	55
BIBLIOGRAPHY .....	113

## ACKNOWLEDGEMENTS

I would like to thank the following persons for their assistance in the preparation of this report. From the National Park Service: Historical Architect Richard Crisson and Architectural Conservator Barbara Yocum, North Atlantic Region Cultural Resources Center; Luis Arana, Historian of the Castillo de San Marcos National Monument; Superintendent William P. Crawford and his staff, Historian Milagros Flores and assistant Marjorie Aponte, of San Juan National Historic Site; Staff Curator William L. Brown III and Audiovisual Producer Brian Jones, of Harpers Ferry Center. From the State of New York: Professors Dr. Ruth Pike and Dr. Altagracia Ortiz. From the University of Puerto Rico at Río Piedras: Dr. Dolores Luque, Director of the Centro de Estudios Históricos, José Cruz Arrigoitia, Nelly Vázquez, and Dr. María de los Angeles Castro Arroyo, Director of the Department of History. From the Archivo General de Puerto Rico: José A. Flores, Archivist. From the Museo del Ejército in Madrid, Spain: Lieutenant-General Colonel Victor Alfonso Lagos and Secretary Miguel Izquierdo Migueliz. From the Archivo General de Indias, Seville: Director Rosario Parra. From the Archivo General de Simancas, Simancas: Secretary María Gloria Tejada. From the Universidad de Seville: Dr. Juan Marchena Fernández. From Canadian Park Service in Ottawa: René Chartrand, Chief Curator.

I am especially grateful for the guidance and administrative support of Sarah M. Olson, former Chief of the Historic Furnishings Division, and for the corroboration of David H. Wallace, Staff Curator, National Park Service, Harpers Ferry Center. Editorial assistant Kam Sloan and Karen Matson have been of great help in seeing this report through to completion.

## ADMINISTRATIVE DATA

### INTERPRETIVE OBJECTIVES

This report has been prepared in response to the recommendations of an on-site study team embodied in a Development/Package Proposal (10-238, Southeast, Package 600, dated March 10, 1988) to upgrade interpretation at El Morro and San Cristóbal, San Juan National Historic Site. The team's recommendations included furnishings or furnishings exhibit panels for the following spaces in Fort San Cristóbal:

For [north] casemates on the oceanside, from left to right [HABS room numbers added]:

1. Latrine [CM-1] - Flat panel exhibit showing how the latrine was furnished
2. Kitchen [CM-2] - Flat panel exhibit showing how the kitchen was furnished
3. Mess room [CM-3] - Refurnish with reproduction furnishings
4. Gun room [CM-4] - Refurnish with reproduction artillery
5. Gun room [CM-5] - Refurnish with reproduction artillery
6. [CM-6 - Fort model; no furnishings]

For the enlisted men's barracks [Troops' Quarters] (first floor):

1. Entrance hall [CM-3] - To be used as the main visitor contact point; will include some reproduction furnishings
2. Casemate [CM-2] to the right of the entrance hall - [theater; no furnishings]
3. Existing theater space [CM-1] - [library; no furnishings]
4. Casemate [CM-4] to the left of entrance hall - [presentation on soldiers' lifestyle; no furnishings]
5. Casemate [CM-5] to the left of #4 - Refurnish as enlisted men's barracks

WW II fire control station:

1. Refurnish to the period 1942-44

Officers' Quarters:

1. When these spaces are vacated, refurnish one as junior officers' quarters and one as senior officers' quarters.

The report presents evidence and recommendations for furnishing one casemate in the Troops' Quarters (CM-5); and a portion of the Guardhouse at the North Casemates (south room). The interpretive period reflected in the furnishings proposed for San Cristóbal Castle is 1790-1800. Within this period both the military defenses of San Juan, Puerto Rico, and the economic reforms instituted in the island during the period of the Enlightened Despotism and under the mandate of the Spanish branch of the Bourbon kings, attained their zenith. By 1788, when the Bourbon Spanish King Carlos III died, the Castillo de San Cristóbal had largely attained its present structural configuration. Soon thereafter the resentment created by those military and economic reforms among the Creole populations of the Spanish-American colonies--for the reforms favored Spain and the Spanish nationals--was to ferment to the point of producing explosive liberating movements that led to the secession of several Spanish colonies from their Mother Country and to their advent as free and independent republics on the American continents.

The refurnished rooms in San Cristóbal reflect the presence of the Puerto Rican Fixed Regiment during the period 1790-1800. This unit performed very well in the field against the British during the attack of 1797; hence, representation of this unit has great interpretive value and is a source of Puerto Rican pride.

The present report also provides furnishings evidence for the following spaces: Latrine (North Casemates, CM-1); Kitchen (North Casemates, CM-2); Mess Room (North Casemates, CM-3); and Officers' Quarters (CM-2). None of these spaces is scheduled for refurnishing at this time. The report makes no specific furnishing recommendations for them.

## **OPERATING PLAN**

The refurnished room in the Troops' Quarters will be designed to operate with or without an interpreter present. A visitor barrier located at the courtyard doorway will allow visitors to view the entire room without entering. An exhibit panel will describe the historic use of the barracks.

The Guard Room as well will operate with or without an interpreter. Visitors will be allowed to enter the room to experience the space and view furnishings and exhibit materials. As in the Quarters, an exhibit panel will interpret the historic use of this room.

A Honeywell Inc. security system was installed in the Barracks Room on December 29, 1992. The equipment installed included:

- 1 Control Panel 5503 with battery
- 4 Magnetic Contacts
- 1 Alarm Siren with Box
- 1 Keypad for secure/access control
- 1 Reflector Beam
- 1 Buzzer
- 1 Motion Sensor

The exhibit rooms are designed to operate without a NPS staff member present.

The expected visitation for San Cristóbal is 1.2 million visitors annually.

### **106 COMPLIANCE**

San Juan National Historic Site will be responsible for initiating the Section 106 compliance process for any restoration work involved in implementing the furnishing plan.

Any modification to the historic structure required to install the recommended furnishings, such as the methods of attaching the sleeping platforms and knapsack racks to the walls in the troops' quarters and the knapsack racks and gun rack in the guardhouse must be reviewed in advance by the Regional Historic Architecture Division.

### **PRIOR PLANNING DOCUMENTS**

Planning documents affecting the use and management of the San Cristóbal Castle are:

HS-202 IDLCS: 01271, Management Category A: Must be preserved and maintained; mgt. date 3/01/81. (The LCS Single Entry Report, dated 01/05/93, states "no treatment until other planning, i.e., GMP, DCP, are completed." San Juan NHS has filed for 106 Compliance for exhibit treatment in exhibit rooms.)

*La Plaza de Puerto Rico; 1765-1777.* Manuscript, by Ricardo Torres-Reyes, San Juan National Historic Site, 1952.

*Historic Structure Report, Part I, Historical Data Section: Officers' Quarters, Fort San Cristóbal, San Juan National Historic Site, February, 1961.*

*Historic Structure Report, Part I: Officers' Quarters, Castillo de San Cristóbal, October 1961.*

*Historic Structure Report, Part II, Architectural Data Section: Officers' Quarters, Fort San Cristóbal, San Juan National Historic Site, 1962.*

*Castillo de San Cristóbal: North Casemates, San Juan, Puerto Rico (Architectural Data Section), 1963.*

*Historic Structure Report Part II (Supplement), Architectural Data Section: Officers' Quarters, Castillo de San Cristóbal, San Juan National Historic Site, 1964.*

*Historic Structure Report: San Cristóbal Gates (RSP-H-2), 1964.*

*Construction History of San Cristóbal: 1634-1800, 1965.*

*Interpretive Prospectus: Castillo de San Cristóbal, a unit of San Juan National Historic Site, 1968.*

*Historic Structure Report, Part I, Historical Data Section: San Juan Fortifications, 1898-1958, 1984.*

"General Management Plan/Environmental Assessment, San Juan National Historic Site, Puerto Rico," 1985.

*Interpretive Prospectus for San Juan National Historic Site, 1987.*

*Fortifications of San Juan National Historic Site: Historic Structure Report, Vols. I-IV (particularly Vol. II: "El Fuerte de San Cristóbal"), 1991.*

The final draft (camera-ready) report, containing original photographs, will be stored within the Division of Historic Furnishings, Harpers Ferry Center. Since no taped interviews were conducted and no documents or records were received in the Division of Historic Furnishings, there is no recommendation for the storage of such material at the park.



## HISTORICAL DATA

### HISTORY OF SAN CRISTÓBAL

Although parts of the fort date from its original construction in the 17th century, San Cristóbal's present configuration is closely associated with the outcome of the Seven Years' War. This war clearly underlined the weakness of the Spanish military to protect its American colonies as well as the superiority of British naval power. At the conclusion of that conflict in 1763 Spain had suffered the temporary loss of La Habana and had to relinquish to the British its North American colonies east of the Mississippi. The Spanish king, Carlos III, and his ministers realized the need to reform their empire. This need, plus the ongoing realization that the Spanish Crown had to strengthen its sovereignty, combined to produce the Enlightened Despotism that was to prevail in Spain at a time when the Enlightenment was sweeping France, Britain, and other European countries. Broad military, economic, administrative and political reforms were introduced to modernize Spain in favor of the national interest, and to increase the Crown's power at the expense of the Catholic Church, the Cortes, and the city councils. Some of the adopted military reforms were intended to halt British expansion in the Americas with one calling for the strengthening of Spain's defenses in the Caribbean. The strategic importance of the island of Puerto Rico, and particularly of the port of San Juan, had long been recognized. The construction of large military installations, planned in accord with the concepts of Field Marshal Alexander O'Reilly, was intended to make San Juan an impregnable fortress. One of the most important of these installations was the Castillo (or Fuerte) de San Cristóbal.

In 1764 O'Reilly was commissioned by King Carlos III to inspect the island of Puerto Rico and to suggest political, and economic reforms. The following year he arrived and after a two month stay he sent the King the perceptive 1765 *memoria* that included observations on all aspects of Puerto Rican life.<sup>1</sup> From the beginning the soldiers sent to conquer the island were too used to military life to dedicate themselves to till the land, he wrote. Two centuries after its conquest, in spite of Puerto Rico's natural resources, its annual income was still not enough to pay the costs of sustaining the colony, and a royal subsidy, or *situado*, had to be sent from Mexico every year. Many people were involved in illegal trade that had somewhat benefited the island's economy at the expense of the Crown. Puerto Rico was not only backward economically but in social development also. Two schools had been established on the entire island to serve its 39,846 white inhabitants and artisans and specialized labor were notoriously missed. Lack of good government and the failure to distribute land to the poor had contributed to the island's underdevelopment. To improve local conditions, O'Reilly introduced a series of economic reforms intended to improve the agricultural output of the island, to eradicate its illegal trade, to enhance its commerce with other neighboring Spanish colonies, and, more important to

the centralizing Crown, to increase Spain's participation in international trade. No social reforms were introduced.

O'Reilly was primarily intent on improving the military defenses of Puerto Rico. Assisted by its able chief military engineer Thomas O'Daly, in 1765 he designed a plan to strengthen the 230-year-old El Morro Castle, the 130-year-old San Cristóbal Castle, the old Fortaleza that doubled as the Governor's house, and to construct two new smaller forts. In addition the San Juan city walls were to be completed with the construction of the north wall that covered the stretch from San Cristóbal to El Morro. After O'Reilly's plans were approved by Carlos III, he secured the necessary funds to finance the new fortifications. He then ordered the acquisition of the needed Spanish artisans and the remaining labor that was largely contributed by forced men and components of army regiments. He made sure that the arms required for the soldiers and the fortifications were supplied from Spain.

The ultimate responsibility for the construction of the San Juan defenses was shared between the chief engineer and the Spanish-born governor of the island who also acted as its captain-general. The work began on January 1, 1766, in spectacular San Cristóbal. The steep terrain required special adaptations in the construction of the various military fortifications and the buildings destined to store arms and provisions and to provide quarters for soldiers and officers. The first known progress reports by the chief engineer are dated three years later.<sup>2</sup> In San Cristóbal the old hornwork defenses were strengthened, the Trinidad counterguard and the San Carlos and Santiago ravelins were added, and the storage and quarters buildings surrounding the Plaza de Armas were completed. By 1788, the year of Carlos III's death, most of this was finished. The somewhat triangular Plaza de Armas was surrounded by the North Casemates, built between 1774 and 1785, where the latrine and kitchen were located; the southeasterly Troops' Quarters, built between 1770 and 1771; and the southwesterly Officers' Quarters, between 1773 and 1775. In addition, at its northwesterly side, the Plaza had a smaller structure, the Guardhouse, which was a distinct component of the North Casemates. It was built in two phases: the earliest, built between 1784-1839, comprising the rectangular south room only, to which two small irregularly-shaped rooms were added on the north side around 1861.<sup>3</sup>

## THE SPANISH FORCES OF 18th CENTURY PUERTO RICO

In the sixteenth century the Spanish Crown decreed that the garrisons defending the citadels and forts of its colonies in the Americas were to be recruited only in Spain.<sup>4</sup> As a result, from then until the eighteenth century, two categories of land troops could be found in the Spanish Indies. One was the regular Spanish army assigned to defend a given colony, and the other was any military force deployed from Spain temporarily. No troops were recruited in the colonies. During the rule of the Bourbon kings in the eighteenth

century, several military reforms intended to strengthen the defenses of the Spanish American colonies were introduced. In a departure from past practice, Felipe V ordered widespread recruitment in the colonies. These armies were to be affixed permanently to the colony of their origin. The first of these to be established was the Fixed Battalion of Cartagena in the Indies. Its regulations issued in 1736 ordered the organization of a military staff and one artillery company and nine infantry companies, each company consisting of 69 men. These units were composed entirely of Cartagenian recruits of whom many were captured stowaways.<sup>5</sup>

During that time, the island of Puerto Rico had been protected from external attacks by two infantry companies of 150 men each, and one artillery company of 64 men, most of whom were from Spain. In addition, after the outbreak of the "War of Jenkins' Ear" in 1739, reinforcements led by Lieutenant General Rodrigo de Torres had been sent to the island in October 1740. It consisted of four companies of the Granada and Aragón Battalions, many of whose 250 soldiers were to remain there, plus a group of 20 artillerymen with a lieutenant and sergeant.<sup>6</sup> In 1741, five years after the formation of the Battalion of Cartagena, a royal regulation created the Fixed Battalion of Puerto Rico. It was to have a military staff, four infantry companies of 84 men each, plus a 64-man artillery company.

Shortly after the corresponding military regulations arrived in Puerto Rico, Governor Matías Abadía began organizing the Fixed Battalion. The original infantry companies were to be the core of his new army to which he added some of the recently arrived artillery reinforcements and a number of locally recruited men. By December 29, 1741, the governor informed the King that he had finished the formation of the new battalion, with some minor modifications resulting from the impossibility of finding all the able bodied men needed. He wrote the King that the Fixed Battalion was composed of four infantry companies of 76 men including sergeants and drummers, and an 80-man artillery company, that included 16 men from the recently arrived forces and a military staff. He had named all the required officers save for one captain, two lieutenants, and two second lieutenants. He had found three qualified persons to act temporarily as artillery officers. The staff was made up of the governor himself, an aide, a chaplain, a doctor surgeon, plus one blacksmith, one carpenter, one gunsmith, one store keeper, and one fortifications foreman.

In April 1742, Governor Abadía informed the King that Puerto Rico was defended by a qualified army of 500 infantrymen and 80 artillerymen. This army was made up of the recently formed Fixed Battalion plus most of the reinforcements brought by General Torres, discounting some 15 men who had died or deserted. These troops were to be housed in El Morro once the old quarters were reconstructed and new ones added.<sup>7</sup> As historical evidence will show below, several of these defenders were Puerto Ricans, recruited not only during or after the formation of the Fixed Battalion, but, more surprisingly, before. After the military reform carried on by Governor Abadía in 1741, three

kinds of land armies could be found in Puerto Rico: the Puerto Rican Fixed Battalion, royal regiments assigned to serve there for periods of several years, and temporary reinforcements sent from Spain when required. The outcome of the Seven Years' War led to the further Bourbon reforms implemented in Puerto Rico by Field Marshal Alexander O'Reilly.

Upon O'Reilly's arrival in Puerto Rico in 1765, he noted that the military organization of the island was also inadequate. In general, he found that many officers were inexperienced, did not enforce the military regulations, and exploited their soldiers. Both the soldiers who arrived from Spain to reinforce the plaza during the Seven Years' War and the locals were very undisciplined. Many were married and lived with their families, and those who were single lived with local women. Officers as well as soldiers lacked adequate uniforms and were poorly equipped. To improve conditions O'Reilly began a series of martial reforms by instituting a new military code. He then proceeded to form a new army from the active soldiers available, to establish a new chain of military command, to reorganize the native militia, and to procure additional military supplies.

In particular, O'Reilly found that both the Fixed Battalion and the reinforcements that arrived from Spain were in great disarray.<sup>8</sup> These reinforcements consisted of two companies, Aragón and España, and two units from the Navarra regiment. Of these reinforcements, O'Reilly sent 15 married men who had abandoned their wives back to Spain and condemned 13 delinquent soldiers to serve in the forts' construction. With the remaining soldiers he formed two companies; one of 69 men and the other of 68, including officers, sergeants, corporals, and two drummers. O'Reilly's reforms of the Fixed Battalion went still further. He found out that, since its inception in 1741, all men lived in huts which they owned or rented. There were 185 married men who had 545 dependents. To create a better battalion he ordered all single men to be quartered in army barracks. He fired 73 useless soldiers and declared 39 additional persons invalids. After subtracting the discharged men, 274 active positions remained. These were distributed through one artillery company and four companies of fusiliers, as shown in Table 1, which is abstracted from the original made by O'Reilly in San Juan on April 18, 1765.<sup>9</sup>

Table 1. Fixed Battalion of Puerto Rico, April 1765

Company	Captain	Lieutenant	Sublieutenant	Sgt. 1	Sgt. 2	Drummers	Soldiers	Total
Artillery	Vacant	José Sánchez	Mateo Sanchez	1	1	2	46	50
Fusiliers 1	Manuel Franco	Gaspar de Andino	Francisco García *	1	2	2	57	62
Fusiliers 2	José Chico	Vacant	Juan A. Valentín	1	2	2	47	52
Fusiliers 3	Manuel Jiménez	Luis Valentín	Melchor Baerga	1	2	2	52	57
Fusiliers 4	Vacant	Vacant	Domingo Maisonet *	1	2	2	48	53
Totals	3	3	5	5	9	10	250	274

\* All officers were married except García and Maisonet.

An examination of the 39 persons serving in the Fixed Battalion and declared invalids by O'Reilly reveals that the recruiting of Puerto Rican soldiers was quite widespread and that it began much earlier than has been thought.<sup>10</sup> On April 18, 1765, O'Reilly prepared a list of all such persons, shown in Table 2.

Of the 39 men listed, 22 (56 percent) were from Spain, 14 (36 percent) from Puerto Rico, and 3 (8 percent) were foreigners. Of the 14 Puerto Ricans, 11--or nearly four-fifths--had served in the army before 1741, and only three had served after 1741. Even though this is a small sample within a group biased in favor of the older people, it clearly shows that in 1765 Puerto Ricans made up about one-third of the Fixed Battalion, and of these about four-fifths had been recruited before 1741.<sup>11</sup>

Table 2. Persons From the Fixed Battalion Declared Invalid in 1765

<u>Name, origin, date service began</u>	<u>Age and Years of Service</u>	
Juan de Plaza, Puerto Rico, 3-1-32	53	33
José M. Carrillo, Puerto Rico, 7-3-20	75	45
Francisco Vela, Puerto Rico, 7-1-36	44	29
José Villegas, Spain, 2-1-42	60	23
Juan Núñez, Puerto Rico, 4-1-43	53	22
Francisco Fañón, Spain, 2-8-34	64	31
Juan B. Lorenzo, Italy, 11-1-38	65	25
Bartolome López, Spain, 7-17-40	65	25
Juan Gracioso, Italy, 10-8-40	64	25
Francisco Atanso, Puerto Rico, 8-1-33	48	32
Marcos Velasco, Puerto Rico, 8-1-35	45	30
Pablo Delgado, Spain, 8-1-36	52	30
Felipe de Peña, Puerto Rico, 8-1-36	44	29
Blas Rodríguez, Puerto Rico, 2-1-38	45	27
Pedro I. Salcedo, Puerto Rico, 1-1-38	49	27
Gregorio Hernández, Spain, 10-1-36	47	29
Lorenzo Ballejos, Spain, 6-1-39	44	26
Pedro de la Olla, Spain, 5-1-30	58	35
Bernabé Cueto, Puerto Rico, 1-1-27	56	38
Antonio Pallero, Spain, 4-6-20	63	45
Antonio García, Spain, 8-1-41	46	24
Juan E. García, Puerto Rico, 1-1-37	46	28
Francisco Guerrero, Spain, 1-1-36	61	29
Jacinto González, Spain, 1-1-26	59	39
Alfonso Vázquez, Spain, 6-1-34	49	31
Francisco Escribano, Spain, 1-1-32	56	33
Nicolás de Parra, Spain, 1-18-32	54	33
Blas Gómez, Spain, 1-1-24	65	41

<u>Name, origin, date service began</u>	<u>Age and Years of Service</u>	
Juan de Andino, Puerto Rico, 7-1-24	48	30
Luis Fernández, Spain, 8-1-35	48	30
Diego de Viera, Puerto Rico, 2-1-42	40	23
José de Candida, Spain, 1-1-42	41	23
Juan de Castillo, Puerto Rico, 1-1-44	38	22
Pedro de Vargas, Spain, 1-1-30	65	35
Vicente Núñez, Spain, 5-1-37	58	28
Diego Moreno, Spain, 1-1-36	47	29
Juan B. de Boria, Austria, 1-1-34	48	31
Juan Díaz, Spain, 1-1-35	54	20 [?]
Pascual Quiroga, Spain, 1-1-36	64	29

In 1766, shortly after O'Reilly's departure, the infantry regiment of León arrived to temporarily reinforce the San Juan defenses. The local authorities, however, continued to recruit locals to fill in the vacant army positions, for the next review of troops in 1766 shows a significant increase in the number of men serving in the regular armies stationed in Puerto Rico. The results of this last review are condensed in the following Table 3.<sup>12</sup>

**Table 3. 1766 Review of Troops Stationed in Puerto Rico**

<u>Fixed Battalion</u>	<u>No. Officers &amp; Soldiers</u>
Artillery Company	66
1st Infantry Company	87
2nd Infantry Company	87
3rd Infantry Company	76
4th Infantry Company	87
Military Staff	4
Invalids	81
Total	488
<u>Spanish Army assigned to Puerto Rico</u>	
Artillery Company	100
Infantry Company	53
<u>Regiment of León</u>	
First Battalion	679
Second Battalion	670
<u>Military Staff for all Puerto Rico</u>	
Total staff	13
<u>Grand Total</u>	2,056

Those recruited in Puerto Rico were supposed to possess a prescribed set of personal characteristics. They were to be between the ages of 18 and 40, robust, in good health, and at least 5 feet tall (many soldiers, however, were 4 feet 8 inches, and some were only 4 feet 7 inches). They were to be white,

save the drummers, who could be black. Preference was given to those born in Spain regardless of their court record, and lacking this, were favored if of Spanish descent. Aside from this stipulation regarding ancestry, the military regulations were not consistent regarding other conditions the Creoles had to satisfy. Preference was also given to those recruits with no occupation, and all were required to be single. Finally, they were supposed to serve in the army anywhere from six to ten years minimum.<sup>13</sup>

The desire to comply with those regulations and the constant difficulty of obtaining qualified men for the army, especially artillerymen, compelled the authorities to recruit on both sides of the Atlantic. In the case of Puerto Rico it is known that in 1785 seventy men were drafted in Catalonia for the artillery company serving in Puerto Rico. In addition, anyone caught hunting illegally within the grounds of the Escorial Castle in Spain was punished by being required to serve eight years in the Fixed Battalion of Puerto Rico.<sup>14</sup> In spite of the stated preference for Spanish nationals in the colonial armies, local recruiting clearly increased the number of Creole soldiers considerably. As recent studies of one historian reveal, the Creole component in the colonial armies increased from 14 percent to more than 80 percent during the eighteenth century.<sup>15</sup> His conclusions, shown in Table 4, may well apply to Puerto Rico also.

Table 4. Spaniards and Creoles in the Armies of the Spanish Colonies

<u>Origin</u>	<u>17th Century</u>	<u>1740-59</u>	<u>1760-79</u>	<u>1780-1800</u>
No. of Spaniards (%)	587 (84%)	328 (31%)	173 (16%)	442 (17%)
No. of Creoles (%)	95 (14%)	731 (69%)	923 (84%)	2,171 (81%)
No. of Foreigners (%)	17 (2%)	4	7	65 (2%)
Totals	699	1,063	1,103	2,678

Another demographic characteristic studied by the same historian was the marital status of soldiers serving in the Spanish colonies in the late eighteenth century. Of a sample made up of 1,434 men, he found that 56 percent were married, 40 percent were single, and the rest were widowers.<sup>16</sup> Again, these percentages probably apply to Puerto Rican soldiers also. This information concerns common soldiers of whom very little is known. Their records are far less numerous and less comprehensive than those of officers of the Spanish colonial forces of Puerto Rico.

For a quarter of a century after the 1766 review of Puerto Rican troops mentioned above (see Table 3), the Fixed Battalion of Puerto Rico was not mentioned in the military reviews. The next known reviews are dated January 2, 1767; July 24, 1768; April 30, 1773; and April 30, 1775.<sup>17</sup> Reports on the first two list the officers' names and the number of soldiers of the two battalions in the León Regiment and the Royal Artillery Company only. The third and fourth reviews were of the infantry and cavalry components of the Disciplined Militia of Puerto Rico only, and their corresponding reports included

the updated service records of all their acting officers.

The next troops review known to have been recorded in Puerto Rico is of special importance for it contains a recommendation to augment the defensive forces of the island. It was made on August 1, 1776, and its corresponding report, signed by Governor Miguel de Muesas, attracted the attention of Count Alexander O'Reilly who forwarded it to Don Joseph de Gálvez, the highest authority on military matters under the King.<sup>18</sup> Governor Muesas' report included a detailed description of all armed forces at his command. It comprised the chiefs of staff, the Royal Artillery Company, the two battalions of the Victoria Regiment that were reinforcing the island, the two battalions of the Bruselas Regiment that had just arrived to replace the Victoria, and the complete Disciplined Militia composed of 18 infantry companies, five cavalry companies, and one company of *Morenos* (dark men).<sup>19</sup> Not one reference to the Fixed Battalion of Puerto Rico is found in this report. Governor Muesas suggested an increase in the size of the Puerto Rican Disciplined Militia whose companies were stationed throughout the island, and even though this was never approved, the King decided the Victoria Regiment should remain in Puerto Rico instead of being sent back to Spain.

Shortly after Governor Muesas sent his recommendation to increase the militia forces he was replaced by Governor Joseph Dufresne. The next troops review finished on December 31, 1776, and was reported by the new governor to the higher authorities in Spain.<sup>20</sup> In the corresponding letter of remittance Governor Dufresne indicated he was reporting all the military forces stationed in the island, namely the Royal Artillery Company, the battalions of the Victoria and the Bruselas Regiments, and all the militia companies. To his report he attached the updated service records of the officers active in all the military forces. Again, no mention of the Fixed Battalion is found in the documents, nor do the officers' records reflect an absorption of this battalion by the militia or by the Victoria and Bruselas regiments. The above comments apply likewise to a similar report written by the same Governor Dufresne on the same troops reviewed in February 1778 and the Victoria and Bruselas regiments reviewed in January 1779.<sup>21</sup>

The next Puerto Rican troops reviews that have survived are dated November 1783 and May 1784.<sup>22</sup> Both included all military forces stationed in the island, namely the Victoria and Bruselas Regiments, plus the Royal Artillery Company, and the militia. The 1784 report explained that, due to the long stay of the Victoria Regiment in Puerto Rico, this unit was quite depleted. Some soldiers had died, others had deserted, still others had been transferred either to the Artillery Company or to the Fixed Battalions of Cartagena and Caracas. That, according to the report, explained why the two battalions of the Victoria were so much smaller. The Fixed Battalion of Puerto Rico was not mentioned in any of the above troops reviews, nor did it appear to be receiving or transferring any soldiers to or from the Victoria, the Bruselas, or the militia.



From the first to the third day of May 1784, the ships transporting the Nápoles Regiment from Spain arrived in Puerto Rico. This regiment had been sent to replace both the Victoria and the Bruselas Regiments that had served on the island for a long time, especially the Victoria that had been there for 14 years. Juan Labán, the governor at the time, sent the authorities in Spain the results of the troops reviews he witnessed in November 1784 and July 1785.<sup>23</sup> Both reviews included the Royal Artillery Company, the two battalions of the Nápoles Regiment, and the militia companies stationed in various parts of the island. Governor Labán concluded in his report that the reduction from two regiments to one required a redistribution of military functions, a reduction of sentinel posts, and the deactivation of several guns. The Fixed Battalion of Puerto Rico does not appear in either of the two troops reviews nor did Governor Labán mention any role it may have played in the military reorganization he was contemplating.

No further references are found in the known historical records about the Puerto Rican army until 1790, when it was reorganized. According to one source, a Fixed Regiment was created having two battalions with nine infantry companies each, plus an artillery company. Most of the soldiers were Puerto Ricans, but some of the most specialized components, such as the artillerymen and the artillery sappers, were from Spain.<sup>24</sup> The next, and last, historical record found regarding this army during the eighteenth century, is a valuable list of all officers active in the Fixed Regiment in 1793 (see Table 5).<sup>25</sup> Sixty-five men from colonel to cadets are listed there along with their rank, name, age, place of origin, and years of service in the regiment. Thirty-seven men (57 percent) were from Spain, 12 from Italy, eight (12 percent) were from Puerto Rico, and the rest were from other Spanish colonies in the Americas, or from France and Germany. Second Captain Ramón Carvajal, remembered today as a subject of the famous colonial Puerto Rican painter José Campeche, appears to have been a lackluster officer, ranked sixteenth on that list. Higher in rank was Assistant (*Ayudante*, a position immediately above second captain) Andrés Jiménez, a Puerto Rican who participated in military actions at Buenos Aires, Santa Catalina Island, the Sacramento Colony, and Ceuta. Other Puerto Ricans listed were Lieutenant Isidoro Arizmendi, the brothers Gil and Joseph Pasalagua, who were the sons of a colonel, Lieutenant Juan Dábila (or Dávila), and three cadets, José María del Toro, Joaquín Goyena, and Francisco Torralbo. A glance at the years of service of some of the higher ranking officers of this regiment leads us to believe that the exact date of the beginning of this reorganization was June 21, 1790, three years, two months and nine days prior to August 30, 1793.

**Table 5. Officers Active in the Puerto Rican Fixed Regiment, August 30, 1793**

<u>Title, Name, Age</u>	<u>Origin</u>	<u>Service Time Yrs, Mos, Days</u>	<u>Previous Service</u>
Col. Joaquín del Sasso, 53	Spain	0, 11, 04	Africa
Lt. Col. Agustín Lassala, 61	Spain	3, 02, 09	Nápoles
Sgt. Major Estéban Desnaux, 57	Italy	3, 02, 09	Nápoles
Capt. Manuel Fernández Torres, 61	Spain	3, 02, 02	Venezuela
Capt. Francisco de Torres, 52	Spain	3, 02, 09	Bruselas
Capt. José Ceresola, 56	Italy	3, 02, 02	Nápoles
Capt. Vicente de Matos, 53	Spain	3, 02, 02	Toledo
Capt. Eugenio Lessene, 60	France	3, 02, 02	Bruselas
Capt. Cosme Sánchez Calvo, 50	Spain	3, 02, 02	Aragón
Capt. Isidoro Linares, 45	Spain	3, 01, 20	España
Capt. Joseph de Vega, 47	Spain	3, 02, 02	Lisboa
2d Capt. Domingo de Aragón, 53	Spain	3, 01, 20	Ceuta
Asst. Andrés Jiménez, 35	Puerto Rico	3, 01, 20	Ceuta
Capt. Federico Garcen, 28	France	1, 02, 18	Nápoles
2d Capt. Manuel de Fuertes, 38	Cuba	3, 01, 20	Victoria
2d Capt. Ramón Carvajal, 44	Spain	3, 01, 20	Bruselas
Asst Maj. Ildefonso de Larrauri, 48	Spain	3, 01, 20	Lisboa
2d Capt. Sebastián de Aguilar, 39	Spain	3, 01, 20	Canaries
2d Capt. Miguel Palatino, 40	Italy	1, 11, 27	Nápoles
2d Capt. Manuel de Aguilar, 41	Mexico	3, 01, 15	Campeche
2d Capt. Marcelo Porrata, 35	Italy	1, 04, 12	Nápoles
2d Capt. Pedro Galiani, 47	Italy	3, 01, 15	Nápoles
Lt. Pedro Marguet, 41	France	3, 01, 15	Bruselas
Lt. Francisco Grasas, 51	Spain	3, 01, 15	Militia
Lt. Cayetano de Ribas, 38	Spain	3, 01, 15	Ceuta
Lt. Pedro Mauduit, 29	Spain	3, 01, 15	Ceuta
Lt. Joseph de la Concha, 31	Venezuela	3, 01, 15	Nápoles
Lt. Julián Artacho y Aledo, 43	Spain	1, 02, 00	Navy
Lt. Cayetano Valero, 37	Spain	3, 01, 13	Nápoles
Lt. Juan Rafael Lassala, 25	Spain	3, 01, 03	Nápoles
Lt. Isidoro Arismendi, 25	Puerto Rico	3, 01, 09	Victoria
2d Lt. Francisco Valderrama, 20	Spain	3, 01, 12	Bruselas
2d Lt. Carlos Savini, 36	Italy	3, 05, 10	Luisiana
2d Lt. Matías del Castillo, 48	Spain	2, 10, 21	King
2d Lt. Gil Pasalagua, 18	Puerto Rico	3, 01, 12	Bruselas
2d Lt. Angel Fantoni, 38	Italy	3, 02, 12	Victoria
2d Lt. Miguel de Lara, 31	Spain	3, 01, 13	Peñón
2d Lt. Francisco Serrate, 21	Spain	3, 01, 13	Crown
2d Lt. Juan Vinals, 39	Spain	3, 01, 12	Cataluña
2d Lt. Josph de la Espada, 41	Spain	3, 01, 12	Nápoles
2d Lt. Luis de Lara, 26	Spain	3, 01, 12	Peñón
2d Lt. Agustín Lassala, 17	Spain	1, 07, 11	Nápoles
2d Lt. Joseph Carrizosa, 26	Spain	1, 08, 07	None
2d Lt. Estéban Fernández, 20	Venezuela	2, 03, 19	Venezuela
2d Lt. Juan Dábila, 22	Puerto Rico	1, 03, 07	Nápoles

<u>Title, Name, Age</u>	<u>Origin</u>	<u>Service Time Yrs, Mos, Days</u>	<u>Previous Service</u>
1st Sgt. Juan Bautista Rover, 43	Italy	2, 11, 00	Nápoles
1st Sgt. Juan Bravo, 34	Spain	3, 02, 07	Murcia
1st Sgt. Bartolomé Lizán, 28	Spain	2, 11, 00	Nápoles
1st Sgt. Joseph Lacomba, 34	Spain	2, 11, 00	Nápoles
1st Sgt. Antonio Martínez, 37	Spain	2, 11, 00	Ceuta
1st Sgt. Luis Gimbernat, 30	Spain	2, 06, 04	Asturias
1st Sgt. Juan Fasán, 33,	Italy	2, 11, 00	Nápoles
1st Sgt. Juan María Ferrari, 30	Italy	2, 11, 00	Nápoles
1st Sgt. Joseph Notario, 31	Italy	2, 11, 00	Nápoles
1st Sgt. Francisco Kerp, 40	Germany	2, 11, 00	Nápoles
1st Sgt. Antonio García, 41	Spain	2, 10, 00	Galicia
1st Sgt. Luis Guineti, 27	Italy	0, 08, 06	Nápoles
Cadet Rodrigo de Ledesma, 20	Spain	0, 09, 00	Canaries
Cadet Joseph María del Toro, 16	Puerto Rico	0, 02, 10	None
Cadet Joseph de Pasalagua, 14	Puerto Rico	2, 09, 21	None
Cadet Joaquín Goyena, 21	Puerto Rico	2, 03, 19	Nápoles
Cadet Pedro de Aragón, 21	Spain	2, 05, 19	Ceuta
Cadet Domingo de Aragón, 19	Spain	2, 05, 19	Ceuta
Cadet Francisco Torralbo, 13	Puerto Rico	1, 09, 21	None
Cadet Nicolás González, 16	Spain	0, 09, 23	None

## HISTORICAL OCCUPANCY

Occupancy of the enlarged San Cristóbal Castle began sometime after May 31, 1775. On that date Engineer Thomas O'Daly wrote to the authorities in Spain that the Troops' Quarters within the castle had been finished. He added that they could be used for housing some of the men of the Victoria Regiment.<sup>26</sup> This regiment that had been sent from Spain in 1770 continued serving in Puerto Rico until 1784 when it was replaced by the Nápoles Regiment. In fact, the Nápoles replaced two regiments, the Victoria and the Bruselas, which had been serving in Puerto Rico since 1776.

As noticed in the preceding section, several accounts of the troops' reviews of the Victoria, Bruselas, and Nápoles Regiments stationed in San Juan from 1770 to 1790 have survived, as well as service records of many of their officers. These documents were used by one historian to analyze the Spanish regiments active in all the Americas between 1733 and 1799, known as the *Ejército de América*. No historical evidence has been found stating who occupied the San Cristóbal barracks between 1770 and 1800. Most likely the troops quartered there were the single soldiers of those three regiments plus those who made up the Fixed Battalion of Puerto Rico.

O'Daly's anticipation, voiced in 1775, that only some of the men of the Victoria Regiment could be garrisoned in the Troops' Quarters, was accurate. Even though only single soldiers were to live in this barracks,<sup>27</sup> the two battalions that composed this regiment could not be accommodated in the eight rooms of the San Cristóbal Troops' Quarters, that could sleep about 216 soldiers and 16

sergeants.<sup>28</sup> This shortage of soldiers' accommodations--aggravated in 1776 by the arrival of the Bruselas Regiment--may have motivated the construction of part of the North Casemates, that by 1783 were estimated to accommodate a battalion in seven of their nine rooms.<sup>29</sup> A small addition to these permanently quartered soldiers were those on sentry duty in San Cristóbal who temporarily stayed in its guardhouse. The rest of the single men lived in whatever accommodations could be secured in town. One document makes reference to a group of soldiers living in houses owned by the local bishop, another to an artillery company living in a large house in San Juan, and a third to some soldiers living in ten old houses in the same city.<sup>30</sup> The quartering of soldiers within San Juan continued to be a problem for most of the remainder of the eighteenth century. Chronicler Abbad wrote in 1782 that many officers and soldiers lived in private homes for lack of adequate military quarters, a shortcoming that may have been corrected to a great extent by the addition of the seven sleeping rooms in the North Casemates within the next three years.

No historical records have been found showing what specific officers were housed in San Cristóbal for any given time either. For that reason, again, no relationship between persons and those structures can be accurately made.

The latrine and kitchen situated in the North Casemates were used by the junior officers, sergeants, corporals, and soldiers who lived in San Cristóbal. Little is known about the administration and use of the San Cristóbal kitchen, however. Nowhere in document or military regulation is there an indication that the army cooked for its soldiers; on the contrary, all evidence points to these men organizing their own cooking and often doing it themselves when they were on active duty or quartered in military barracks. All soldiers were assigned a meager salary that was intended to cover their uniform, hospital, and medicinal expenses, a small amount of cash for their personal use, and their daily rations that came out of the royal stores.<sup>31</sup> These carefully regulated rations, consisting of imported and local foodstuffs, depending on their availability, were kept in the local stores and were doled out by a royal officer, the *Guardalmacén de Víveres*.<sup>32</sup> Soldiers, junior officers, convicts (forced labor) and other workers of the military installations, all of whom received official rations, were encouraged by their superiors to group in small units to do their own cooking.<sup>33</sup> This encouragement was furthered and clearly recognized by some of the designs of the military engineers. Of the two large barracks planned for Santo Domingo on the island of Hispaniola in 1757 and 1760 respectively, one was to be equipped with 24 small kitchens and the other with an area of 195 feet, where a string of small kitchens were to be placed.<sup>34</sup> The kitchen utensils may have been provided by the army, however. The León Regiment stationed in San Juan in 1768 was equipped with cooking utensils and various pots.<sup>35</sup> A distinction should be made between the kitchen organization of a military fort and a hospital. Hospitals employed cooks who prepared meals for the patients.

## EVIDENCE OF FURNISHINGS

Historical evidence concerning the furnishings of San Cristóbal between 1780 and 1800 is rather limited, but can be supplemented by evidence concerning comparable sites in the Spanish colonies derived from a number of pictorial and written sources. The pictorial sources comprise about 100 architectural plans and drawings, and a few artist's renditions kept in the Archivo General de Indias, the Servicio Geográfico del Ejército, and the Servicio Histórico Militar, in Spain. The written sources consist of documents kept in the Archivo General de Indias in Seville, Spain; the General Archives of Puerto Rico in San Juan, Puerto Rico; the Archivo Nacional of Cuba in La Habana, Cuba; the Archivo General de la Nación in Mexico City, Mexico; and the East Florida Papers at the P. K. Yonge Library of Florida History in Gainesville, Florida.

A substantial number of the architectural plans and drawings used have been reproduced in printed books included in the bibliography of this report; the rest were found in the military library of San Juan National Historic Site or obtained from the Archivo General de Indias by mail. The Museo del Ejército in Madrid, Spain, contains many original items related to Spanish military history, yet, according to its subdirector, no material related to the furnishings used by officers and soldiers during the period considered here is found in the collection.

The written sources used in this report comprise documents, books, and other publications. Many of the documents are found in photostatic, xeroxed, or microfilmed copies kept in the military library of San Juan National Historic Site, the North Atlantic Region Cultural Resources Center of the National Park Service in Boston, and the Centro de Estudios Históricos of the University of Puerto Rico at Río Piedras. Transcriptions of some documents are found in books and publications. The original documents consulted are in the General Archives of Puerto Rico and in the P. K. Yonge Library of Florida History. The books are from the military library of the San Juan National Historic Site, the Libraries of the University of Florida in Gainesville, Florida, the North Atlantic Cultural Resources Center of the National Park Service, the Libraries of the University of Puerto Rico and its Centro de Estudios Históricos in Río Piedras. A few others were obtained through the interlibrary loan service of the University of Florida Libraries, especially from the New York Public Library. A good number of old books are available on microfilm in the military library of the San Juan National Historic Site.

The documents yielding the most information on furnishings have been those from the section "Audiencia de Santo Domingo" in Archivo General de Indias that contains the bulk of communications between high government officials stationed in the Caribbean colonies and those in Spain. Inventories taken of the contents of forts including their guardhouses, royal stores, latrines, kitchens, hospitals, churches, governors' houses, and custom houses are found in that Audiencia section. Due to the high rank of the persons among whom

those documents circulated, however, very few details, if any, are found about the furnishings they mention. The second important source on furnishings has been the original architectural plans of eighteenth century military installations kept in the Servicio Geográfico del Ejército, and the Servicio Histórico Militar, in Madrid. Some of these plans are found in Archivo General de Indias also.

The historical sources from which were derived information about the furnishings of the military installations of San Juan, Puerto Rico, were complemented by those relating to other similar buildings erected or planned in other parts of the Spanish-American colonies, especially those located in the Caribbean area. Thus, examples of furnishings found in Colombia, Florida, Mexico, Santo Domingo, Venezuela, and even Peru and Chile are cited. The centralizing policies of the Spanish Crown contemplated control of its Spanish-American colonies from Madrid and other Spanish urban centers, by means of governors and other high colonial officials. These men were usually born in Spain and naturally adhered to Spanish law. The Crown protected her colonies with army regiments largely directed by officers born in Spain, who followed Spanish regulations and who operated in installations designed by military engineers educated in Spain. Thus was reinforced that uniformity found in the language and cultural representations--including architecture--of the Spanish-American colonies, allowing for some local diversity, of course.

Soldiers stationed in military installations in Mexico, Venezuela, and even Chile, slept in an identical type of bed, made from various local woods and apparently using cushioning of local origin. In contrast to the lack of detail about the furnishings typical of the documents originated by high government officials, those from the Spanish governor operating in Florida contain correspondence of a much lower administrative level, namely between the governor and his local officers. These documents--which are among few surviving governors' papers--are an invaluable complementary source, for they contain greater detail about furnishings. They describe, for instance, the types of woods and the sizes and thicknesses of the boards used. Puerto Rico, no doubt, was a poor colony when compared to Mexico or Peru. But it was no poorer, nor less inhabited, nor less politically important than Florida. No significant differences in those military furnishings used in the various Spanish colonies of the Americas, whether poor or rich, are apparent.

Save for the furnishings used by the highest government officials, who were privileged to bring into the colony their personal belongings free of duty, much of the furniture used in the military installations of Puerto Rico was locally made. The late eighteenth century visitors who wrote about the conditions they found on this island, such as Marshal O'Reilly, Vizcarrondo, Mirayes, Abbad, and Ledru (see Note 1), noted that artisans and specialized labor were so scarce in Puerto Rico that they had to be brought from Spain. The construction of the Puerto Rican military installations which utilized imported skilled labor such as carpenters, masons, and blacksmiths, is well documented. Those Spanish artisans who made all the building components such as windows

and doors, must also have made the soldiers' sleeping platforms, benches, tables, chairs, gun racks and knapsack racks, and other furniture used in the army quarters. The case of Florida is well reflected in its governors' papers. All furniture of official use mentioned in those documents was locally made.

Contrary to the local origin of most of the wooden furniture used in the military installations in San Juan, it appears that practically all metal utensils were imported. The extensive lists of goods brought from Spain and other Spanish colonies to Puerto Rico during 1790 are revealing.<sup>36</sup> All sorts of foodstuffs--including garlic, preserves, wine, oil, bacon--plus dinnerware, flatware, cooking pots, frying pans, and kettles, came from Spain. The only deviation found is the one shipment of 128 Mexican chairs that landed in San Juan the same year.

Although the pictorial evidence in Figures 27 and 28 is French in origin, the Spanish government in many ways copied their military establishment directly from the French, as seen in similar fortifications, artillery, uniforms, and equipment. Thus these French representations are good indications of what the Spanish used. Figure 27 is a photograph of a guardroom at Fort Niagara, New York. The sleeping shelf was restored in the 1930s from original remains. This type of sleeping arrangement is identical to that historically used in the barracks and guardroom at San Cristóbal. Figure 28 is a drawing by Claude Massé, engineer, from his *Livre des Fortifications...circa 1687-1728* and shows in great detail barracks furniture that will serve as prototype forms for use in San Cristóbal.

### **Evidence for Specific Rooms**

The following references were found regarding the furnishings of latrines, kitchens, guardrooms, enlisted men's barracks, junior officers' quarters, and mess rooms.

#### **Latrines**

The westernmost vault (CM-1)<sup>37</sup> in the North Casemate was identified as a *lugar comun* or latrine in Juan Francisco Mestre's 1783 drawings and 1785 report on construction at San Cristóbal; see Vol. II, p. 39 and figs. 2.11 and 2.12 on p.40, of "The Fortifications of San Juan National Historic Site" (1991). Later documentation for its continued use as a latrine is provided by Manuel Castro's 1861 plan of the Latrine and Kitchen<sup>38</sup>, and Leon de Castro's 1868 plan.<sup>39</sup>

Several other historical sources help us to reconstruct the probable appearance of the San Cristóbal latrine. These sources include details of the removable wooden covers with rounded holes that made up the top of the latrine boxes,

and the installation of those boxes over ditches, along rivers, on beaches, or over dry holes in the ground. Those sources also document the use of wooden floor platforms secured to the floor of the latrine room, and the equipment used for latrine service and cleaning. Finally, these sources provide a glimpse of the neglected condition of the latrines during some periods.

1. FIGURE 1 shows the layout of the San Cristóbal latrine in 1861, with 18 privy holes for enlisted men; two partitions provided separate pairs of seats, presumably for the use of non-coms and officers. There was also a rectangular feature on one wall, probably a urinal trough.<sup>40</sup>

2. The minutes of the meetings of the San Juan City Council referred on several occasions to latrines:<sup>41</sup> a) On May 27, 1771, Francisco Goveo and other residents of the Campeche barrio in San Juan complained to the city council about the stench coming from the latrines used by the troops quartered in the bishop's houses. They were afraid that a pestilence might generate there, and they asked the Council to solve the problem. b) On September 28, 1770, the City Council approved the purchase of two buckets for pouring water in the latrine of the local prison. c) Book of Acts 1777-1781, p. 130, notes the prison *alcaide* requested two buckets and a water tub for the prison latrine. d) On November 10, 1783, the prison *alcaide* requested a bucket and a water tub for the prison latrine. e) On February 27, 1804, the prison *alcaide* asked the City Council to have the prison latrine cleaned, its wooden floor repaired, and to provide seven buckets for use in that latrine. f) On December 15, 1806, the prison *alcaide* requested the Council to have the latrines emptied and cleaned to prevent the possible dispersal of disease. Five months later, on April 27, 1807, a carpenter presented a 140 pesos estimate to repair the latrines (wooden floor and latrine covers), but he added that the emptying and cleaning of that place had to be done by others.

3. FIGURE 2 shows the latrine of the San Juan Government House, 1758.<sup>42</sup> The latrine cover with its six rounded holes are clearly shown.

4. FIGURE 3 shows two details from the floor plans of the barracks that were to be constructed in Santo Domingo, Hispaniola, in 1757.<sup>43</sup> Detail 1 shows two adjacent latrine rooms. One room housed a latrine with 10 privy holes for the use of common soldiers and the other room another latrine with two privy holes for the use of officers. The plan depicts the wood construction of the service covers and the wooden floor of the latrine rooms.

5. FIGURE 4 reproduces the first floor plan of the Charity Hospital of San Juan drawn in 1778. Letter P designates a latrine with five privy holes, plus a larger sixth station, probably used for the patients' chamber pot servicing.<sup>44</sup> This floor plan also shows two small latrine rooms (G) and adjacent to them two small kitchens, probably used by the staff of the hospital.

6. FIGURE 6 shows a latrine with sixteen privy holes with individual



divisions to provide better privacy. This latrine room was planned as part of the barracks to be constructed in Santo Domingo, in 1760.<sup>45</sup>

7. New latrines with four divisions had been constructed in the soldiers' barracks of St. Augustine, Florida, by December 1788. Each division had two removable wooden boxes to facilitate the cleaning of the place.<sup>46</sup>

8. A wooden box with two privy holes was installed in the latrine room of the Treasurer's house in St. Augustine, Florida. The box was made of two parts to facilitate the cleaning of the latrines.<sup>47</sup>

9. By December 31, 1790, the latrine room in St. Augustine's Government House had been repaired and two big water vats had been installed next to the latrines.<sup>48</sup>

10. The following repairs and building modifications had been made in the Castillo de San Marcos in St. Augustine, Florida, in 1792. The troops' latrines, which were made of wood, were removed from their original place and reassembled over six pillars erected close to the beach.<sup>49</sup>

11. The 1789 inventory of the contents of the troop barracks of St. Augustine, Florida, listed four latrine rooms with four boxes fitted on stakes and equipped with iron handles for easy removal and cleaning.<sup>50</sup>

12. The inventory taken in 1791 of the hospital building of St. Augustine, Florida, listed a latrine room with wood walls and a latrine wood box with three privy holes and a cover with iron handles that could be removed for easier cleaning. There were two large water tubs nearby.<sup>51</sup>

The above references suggest that the San Cristóbal latrine probably included the following objects:

**Latrine Boxes.** According to the historical evidence gathered, the latrine rooms were equipped with wooden boxes providing individual seating for one, two, or three persons. The covers of all boxes had rounded privy holes. Sometimes the covers were independent of the rest of the box and were equipped with iron handles for easy removal and cleaning of the latrine water channel over which the boxes were installed. At times, boxes were equipped with iron handles for easy removal from skates planted on the floor to which the boxes were anchored. The latrine boxes at the San Cristóbal north casemates may have been placed on brick supports similar to those existing in the latrine room of El Morro.

**Urinal trough.** The long rectangular feature along the south end of the east wall (see Figure 1) may have been a urinal trough.

**Wooden platforms on latrine room floor.** The floor area of the latrine

room in front of the latrine boxes was sometimes covered with a wooden platform for ease of maintenance and to keep that area dry probably for a more comfortable usage of the latrines.

**Water buckets.** Even though the San Cristóbal latrines were kept clean by means of piping that directed the rain water from the main plaza to the latrine room, water buckets presumably were used to help keep this room clean during the dry season. These buckets would have been filled with water taken from a larger tank or container--tub or vat--located close to the latrine room.

**Water tubs.** Tub or vats located close to, or in, the latrine rooms stored water to supply buckets used to keep the latrines clean. Ample exterior space for water tubs was available in San Cristóbal, therefore, no water tubs are suggested inside the San Cristóbal latrine room.

The San Cristóbal latrine is not scheduled for restoration at this time. Its presumed 1780-1800 appearance will be depicted on a wayside exhibit panel based largely on the 1861-1868 plans drawn by Manuel Castro and Leon de Castro which show a long rectangular feature, probably a urinal trough; and 18 privy holes, four of which were partly partitioned off, presumably to give officers and non-commissioned officers some degree of privacy.<sup>62</sup>

Additional details, derived from comparable structures cited above, will include a seat cover with iron handles for every pair of privy seats, raised wood platforms in front of the two rows of privy seats, and four wooden buckets.

## **Kitchens**

The second vault (CM-2) in the North Casemate was identified as a *cocina* or kitchen in Juan Francisco Mestre's 1783 drawings and 1785 report on construction at San Cristóbal; see Vol. II, p. 39 and figs. 2.11 and 2.12 on p. 40, of "The Fortifications of San Juan National Historic Site" (1991). Later documentation for its continued use as a kitchen is provided by Manuel Castro's 1861 plan of the Latrine and Kitchen<sup>53</sup> and Leon de Castro's 1868 plan.<sup>54</sup>

About 1830, work on the North Casemates included plastering and whitening (probably whitewashing) and "adding iron rods [grilles?] to the kitchen fires...[and] adding to shelves and a box 10 *varas* long," possibly for the kitchen.<sup>55</sup> Manuel Castro's 1861 floor plan of the kitchen shows the outlines of what may have been shelving and/or cabinets along the west wall and a six-burner stove in the southeast corner, with a large rectangular feature next to it, possibly the *carbonera* (charcoal kiln or coal bin?) constructed in 1858.<sup>56</sup> The survival of what appears to be a stovepipe hole in the south wall, southeast corner, confirms the placement of the stove; the other features can not be documented as existing before 1830.

Analysis of many layers of paint on the lower plaster wall of the kitchen vault suggests that the lower walls were painted a dark color such as black, gray or red. The earliest layer found was red, but without documentation or a datable element for comparison, the architects feel that it is not possible to determine if that was the original color.<sup>57</sup>

The following historical sources provide additional evidence on Spanish colonial kitchens, stoves, water containers, furniture, cooking and serving utensils. Two late eighteenth century descriptions of the cooking facilities found in Puerto Rican houses are also included for they contribute to understanding the relative importance that the preparation of meals had in the daily life of the inhabitants of the island.

1. An inventory of all the furniture and utensils found in the kitchen located within the walls of the San Juan forts was taken in 1768.<sup>58</sup> Its complete list is as follows: four cooking kettles, one brass pan (*paila*), one useless brass pan, one serving pan with brass handles, one useless serving pan, two serving iron pots, two iron ladles, one useless iron ladle, one serving iron grill, two frying pans, two mortars, one meat knife, one machete, one axe, one fork, one table with two drawers, two medium size serving trivets, two useless serving trivets, two small wooden trays (*bateas*), one water vat, one large water jar, and one large earthen pot. An inventory was taken of the contents of the Royal Hospital located within the same walls also. It included the following furnishings: 217 leather cots, three tables with two drawers, four tables with one drawer, one table without drawer, eight large metallic candle holders, 137 jars, 110 dishes, 65 bowls, five small earthen casseroles, eight medium size water vases, four feeding jars (*pisteros*), 18 glazed jars, 103 servers (chamber pots?), 20 boxes for servers, 20 useless boxes for servers, 51 medium size spittoons, six benches, one wooden chair, one useless wooden chair, two medium size leather chairs, two coffers with locks, and two metallic candle holders.

2. An inventory of all the contents of the San Juan royal stores was made on March 1, 1773.<sup>59</sup> It lists the following items associated with the preparation and serving of meals: 24 water vats, 41 water quarter-barrels, 153 water barrels, 11 wood pitchers, 86 wooden dishes, six small tubs, 33 empty jars, 13 copper kettles with lids, nine copper pots with lids, 12 serving copper ladles, 13 copper skimmers, 17 bronze weights, six small axes, six knives, five large pantry knives, and, nine tin funnels. In addition, the same inventory lists the following edibles: 1067 hundredweights of hardtack, 12 hundredweights of chickpeas, one hundredweight of rice, 14 hundredweights of cod, two hundredweights of rye, 119 barrels of meat, 57 barrels of bacon, four barrels of vinegar, 18 cheeses, and 37 jars of oil.

3. FIGURES 4 and 5, contain a 1778 plan of the Charity Hospital in San Juan, Puerto Rico.<sup>60</sup> Figure 4, the first floor plan, shows the kitchen (M) with a five-burner stove and what seems to be an oven, probably for baking

bread. Figure 5, the second floor plan, shows a larger kitchen (*cozina y refectas*) with a thirteen-burner stove and an area for serving meals (H).

4. FIGURE 8 shows a 1712 floor plan of the seminary in San Juan. It contains an eight-burner island-type stove and what seems to be space for an oven.<sup>61</sup>

5. FIGURE 13 displays the 1769 plans of a gunpowder house in San Juan.<sup>62</sup> They include details of the guards' quarters and a kitchen with a two-burner stove adjacent to these quarters.

6. A 1783 document indicates the kitchen and the adjacent latrine of the San Cristóbal Castle had been finished. It notes that the rainwater collected on the upper platform (*batería*) floor was routed to keep those places clean.<sup>63</sup>

7. The kitchen of the San Gerónimo Fort in San Juan was restored in the 1960s. One photograph of the same showing its stove, chimney, table, and kitchen utensils appears in a printed book.<sup>64</sup>

8. Visitor Fray Iñigo Abbad y Lasierra wrote about how rudimentary the kitchens of many Puerto Rican homes were in 1782. He described how meals were prepared on an open fire arranged directly on the patio floor, under a papaya or banana tree, or under a primitive roof made for the purpose.<sup>65</sup>

9. In 1792, visitor André Pierre Ledrú described the primitive conditions of most Puerto Rican kitchens, their stoves and cooking utensils. He wrote that "the kitchen utensils are merely a few earthen pots and pans made from coconut shell and gourds. The kitchens do not have chimneys and the fire is set among four rough stones located in the middle of a room, on which the cooking pot containing the stew is placed."<sup>66</sup>

10. A 1777 plan of the barracks to be constructed in Cumaná, Venezuela, included a kitchen with a seven-burner stove.<sup>67</sup>

11. FIGURE 3, detail 2, shows 24 small kitchens planned for the projected barracks of Santo Domingo.<sup>68</sup>

12. FIGURE 7 shows the floor plan of an artillery installation in Campeche-Mérida, Mexico, 1792. It includes a kitchen with a three-burner stove.<sup>69</sup>

13. FIGURE 9 depicts a reconstructed colonial Venezuelan kitchen, including the stove and its large chimney.<sup>70</sup> Notice the similarity of this kitchen to the reconstructed San Juan kitchen of colonial times displayed in the Museum of the Puerto Rican Family in San Juan.

14. FIGURE 10 shows the floor plan of a colonial house kitchen with a

three-burner stove, in Coro, Venezuela.<sup>71</sup>

15. A construction report on an eighteenth century Venezuelan port indicated the kitchen, which included an area for salting meat, was already finished.<sup>72</sup>

16. The 1765 floor plan of the Parén fort in Chile, included a kitchen and adjacent to it, a bakery for bread only (*panadería*).<sup>73</sup>

17. A modern author provides a description of eighteenth century kitchens in St. Augustine, Florida. What was cooked in them is worth transcribing here. "On December 31, 1791, the kitchen was described as being adjacent to the pantry with a high chimney, a table, a *parador* of wood, shutter door and shutter windows, and iron work. Stoves may have had three or more openings in the top with covers. The earthenware pots seemed to fit directly over the hole. Spanish colonials brought with them from Spain the practice of combining foods into *olla podrida*, a stew of an innumerable combination of meat and vegetables cooked together in an earthenware vessel. Meats commonly used in Spain were sheep, hares, hens, geese, and game birds. They were combined with such vegetables as carrots, potatoes, peas, onions, and cooked together in a large stew pot for many hours. The method was transferred from Spain to the Americas where it was very similar to the aboriginal methods. Here other types of vegetables--cassava, yucca, sweet potato, peanuts, arrowroot, maize, beans, peppers, and squash--were added."<sup>74</sup>

18. "Each workman [during the construction of the San Juan forts] did his own cooking, unless he threw in with others or had a woman to cook for him."<sup>75</sup>

19. Another author described a 1787 kitchen in St. Augustine, Florida: "The kitchen of the Customs House was most likely one of the better ones. It was a twelve by fifteen foot room with two doors and three windows tacked onto one of the wings of the building. An oven and a brick stove, its three burner top about twenty eight by forty-eight inches flanked the fireplace."<sup>76</sup>

20. According to a 1786 document, an oven and a stove with several burners were constructed in the kitchen of the Treasurer's house in St. Augustine, Florida.<sup>77</sup>

21. The barracks planned in 1760 for Santo Domingo, included a large and narrow area, about 18 feet wide by 195 feet long, intended to house several cooking stoves. The chimneys of these stoves are clearly depicted in the drawing.<sup>78</sup>

Restoration of the San Cristóbal kitchen is not under consideration at this time; it will be interpreted by a wayside exhibit panel, with an artist's impression of its appearance in the late 18th century. As with the latrine, the

available site-specific information on the room's contents comes from the 1861 and 1868 plans by Manuel Castro and Leon de Castro.<sup>79</sup>

According to the Historic Structure Report, the structure of the north casemate (CM-2) where the kitchen was located in the San Cristóbal Castle suffered an important modification prior to 1861. Its original doorway and window on the south wall facing the plaza as shown in the 1783 plans, no longer appeared in the 1861 drawings. By this year the entire south wall was open to the plaza. These drawings show a six burner stove located in the southeastern corner of the casemate, and next to the stove, a probable coal bin. The stove location seems to be corroborated by what appears to be the remains of a stove pipe hole in the south wall.<sup>80</sup> Chimneys were so common to all Spanish-American kitchens that it is almost certain that the San Cristóbal stove had its chimney also. Since it is likely that the casemate structure--which was bombproof--would have been weakened by placing a chimney through its roof, it is conceivable that the chimney was routed out of the casemate above the entrance door and up beyond the ceiling level.

**Stoves.** The San Cristóbal kitchen must have had a stove from its first day of operations. The stove location may have been the same shown in the 1861 drawing considering the need for ventilation and dissipation of the smoke. However, it is unlikely that it was two burners deep for that type of arrangement would have been unique for its time. Except for one instance, all the stoves mentioned in this report have their burners side by side. Wood, and more rarely charcoal, were used to feed the fire just under the cooking surface and beneath that was an empty space to collect and remove the ashes. The smoke produced by the fires was drawn by a chimney that covered all the cooking surface.

**Ovens.** The structural remains of El Morro Castle kitchen suggests an oven existed there. If this proves to be fact, it is likely that the San Cristóbal kitchen had an oven also, mainly for baking bread. Wheat flour is the staple most commonly mentioned in the contemporary acts of the San Juan City Council.<sup>81</sup>

**Kitchen utensils.** Utensils used for the preparation and serving of meals, plus storage recipients are considered here. The utensils to be found in the San Cristóbal kitchen should have been similar to those known to exist in other royal buildings of San Juan at the time: cooking kettles, copper kettles with lids, brass pans, frying pans, earthen casseroles, copper pots with lids, mortars, meat knives, machetes, axes, forks, wooden trays, serving pans with brass handles, serving iron pots, iron ladles, copper ladles, copper skimmers, tin funnels, serving iron grills, serving trivets, water vats, water barrels, quarter-barrels, large water jugs, glazed jars, large earthen pots, wooden dishes, wooden pitchers, bowls, and medium size water vases.

The following objects mentioned in the 1768 inventory of a kitchen located within the San Juan walls (see 1. above), would be appropriate to show in a conjectural drawing of the San Cristóbal kitchen:

- 2 2-1/2 x 5.0 feet tables with two drawers each
- 4 cooking kettles
- 1 serving pan with brass handles
- 2 iron ladles
- 2 frying pans
- 1 meat knife
- 1 axe
- 2 medium-size serving trivets
- 1 water vat
- 1 large earthen pot
- 1 brass pan (*paila*)
- 2 iron serving pots
- 1 iron serving grill
- 2 mortars with pestles
- 1 machete
- 1 large fork
- 2 small wooden trays (*bateas*)
- 1 large water jar

## Guardhouses

In 1783, a small, two-room guardhouse was built onto the north end of the Officers' Quarters, next to the Main Gate. Later, but before 1839, a more substantial guardhouse (*Casa de la Guardia* or *Cuerpo de Guardia de la Tropa*) was constructed at the northwest corner of the Plaza as a distinct component of the North Casemates. The north section of this trapezoidal structure was added around 1861. At this point it is impossible to say whether or not the Guardhouse at the North Casemates, as it is called today, was in use at the end of the 18th century.<sup>82</sup>

Twenty historical references contribute to illustrate how common soldiers, corporals, sergeants, and junior officers were housed in the guardrooms of a Spanish-American military post. These references indicate how those differently ranked persons were distributed in the guardrooms, and what sort of bedding and other furnishings were provided for their personal comfort and for accommodating their arms and personal belongings. The information contained here allows us to reconstruct the shape and size of the sleeping platforms and the space allotted per soldier, and the general configuration of the storage racks and armsracks provided to these men. These historical references also help to reconstruct the furnishings found in the rooms used by officers and sergeants, such as their bedding, seating and storage facilities, tables, and accessories such as lighting fixtures, water jugs, pedestal tables, and braziers

when required by the local climate.

1. FIGURE 13 shows the 1769 floor plans of a gunpowder warehouse in San Juan. Three hundred and fifty feet away (54.5 *toesas*) the guardhouse was located. It consisted of two rooms, one with wooden platforms for the common soldiers to sleep on (I) and another, unfurnished room for the commander (H). A side view of the soldiers' quarters (extreme upper-right) shows the slant of its wooden platforms. The kitchen is located at the left of the soldiers' quarters (L).<sup>83</sup>

2. On September 9, 1769, a detailed inventory of the contents of the guards' quarters in San Juan was made. The following items were found in the soldiers' quarters: three sleeping platforms including one for the sergeant, one water storage tank, one vat for taking water out of the tank, one lantern, four windows with their iron hardware, one entry door with its lock and iron hardware, five crossbars and ten wedges for securing the windows, five pikes with steel ends, two gun racks in the soldiers' room and two at the entrance hall, and three clothes hangers.<sup>84</sup>

3. In 1776 Engineer Thomas O'Daly made a budget to cover the construction of the Miraflores gunpowder deposit in San Juan. The wood needed to make the platform of the guards' quarters included several beams about 10 feet long (4 Castilian *varas*) by 4 to 5 inches thick, and part of the 220 wooden boards estimated for the total project. The officer's room was to be separated from the common soldiers' room. The labor cost was calculated for the total work, including the manufacture of the wooden platforms, one gun rack, and a knapsack rack.<sup>85</sup>

4. The guards' quarters of the Custom House of San Juan, 1784, are included in a floor plan dated 1784. It shows the dormitory for the common soldiers and corporal with its sleeping platforms, and the officer's room.<sup>86</sup>

5. FIGURE 11 depicts the guards' quarters of an artillery installation in Campeche, Mexico, 1792.<sup>87</sup> It shows the wooden platform where the common soldiers slept and an adjacent room--unfurnished--for the commander. A cut-up view of the soldiers' room shows a profile of the wooden platform, and equally important, a profile of the rack and hanger for the soldiers' knapsacks and clothing.

6. FIGURE 12 shows the floor plan of the guards' quarters in a military installation in Campeche, Mexico, 1802. The quarters were made up of a common soldiers' room with its wooden platforms for sleeping, and an adjacent commander's room with one individual sleeping platform. A vertical section of the soldiers' room depicts a profile of the slant of the sleeping platforms.<sup>88</sup>

7. FIGURE 14 contains a floor plan of an eighteenth century Venezuelan gunpowder storage facility. The guards' quarters are located to its right.<sup>89</sup>



8. A plan of the military installation constructed in Valdivia, Chile, in 1762, depicts one building containing a calaboose and the guards' quarters. Two braziers, two large water jugs and a U-shaped sleeping platform are shown in the calaboose. The guards' quarters are made of two adjacent rooms, one for the use of the guards and one for the officer. A U-shaped sleeping platform, a pedestal table and a gun rack are included in the guards' room. The officer's room contains a cot only.<sup>90</sup>

9. The guards' quarters, a kitchen with its chimney, and a room with three latrines as planned for the Viceroy's house in the Real Felipe Fort, Callao, Perú, in 1762, are shown in a plan.<sup>91</sup>

10. A wooden platform for 12 soldiers was made for the warehouse guardroom in St. Augustine, Florida, in 1785, as well as a fireplace that doubled as a kitchen. A new pine platform for four soldiers and a corporal was delivered to the Treasury's guardroom.<sup>92</sup>

11. Two pine platforms, one for two corporals and 12 soldiers, and the other for the sergeant, were delivered to the guardhouse of Bibac, Florida, in 1784.<sup>93</sup>

12. A 1790 report indicated that one hundred steps away from the gunpowder warehouse of St. Augustine, Florida, a guardhouse was built. It had the usual division that separated the sergeant's room from that of the corporal and eight soldiers, gun racks, and wooden sleeping platforms.<sup>94</sup>

13. A room for the guard unit at the St. Augustine hospital contained one sleeping platform, one gun rack, and a division between that room and the kitchen.<sup>95</sup>

14. An inventory was made of the contents of a guardroom in St. Augustine, Florida, in 1800. This room had a wooden platform for the troops and another for the sergeant, one table, one bench, one board on which to affix written orders, and one lamp support.<sup>96</sup>

15. A 1789 inventory of the contents of the St. Augustine guardroom at the troop barracks listed gun racks, two new platforms for the use of the common soldiers and one for the sergeant.<sup>97</sup>

16. The following items were delivered to the guard at Bibac, Florida, in 1790: two new pine benches--a large one for the troops and a small one for the sergeant, and one new prison rack with six holes in its wood frame--two for the heads and its corresponding iron accessories.<sup>98</sup>

17. One new pine bench for the hospital guardroom in St. Augustine, Florida, was delivered in 1790.<sup>99</sup>

18. An inventory of the guards' quarters at the St. Augustine hospital was taken in 1791. It listed a single room used for the purpose, and it contained a fixed wooden platform for five soldiers and a corporal, a table, a small bench, and a gun rack.<sup>100</sup>

19. In 1792, the guardroom at Hornabeque, Florida, had a wooden floor. The room was furnished with a soldiers' platform that ran along all the wall, a single platform for the corporal, a bench, a table, and a gun rack.<sup>101</sup>

### Troops' Quarters

The two-story Troops' Quarters (*Cuarteles*) on the east side of the Plaza was constructed in 1770/71, providing 10 bomb-proof vaults to serve as quarters for enlisted men and their non-commissioned officers. In 1970, the first floor was adapted for interpretive purposes, CM-1 housing an audiovisual program, CM-2 and CM-4 exhibits. The northernmost vault on the first floor (CM-5) was left unrestored. In its walls survives evidence of the wall pockets for the original sleeping platform supports, uncovered during architectural investigation in the 1970s.<sup>102</sup>

The following historical sources provide evidence on how the common soldiers' dormitories were furnished. They describe their beds and the sleeping space allotted per soldier, the gun racks and the iron and wood racks provided for storage of soldiers' knapsacks and clothing. Substantial similarities exist in the soldiers' beds provided in the barracks and in the guardrooms described above.

1. The 1741 army regulations (*Reglamento*) applicable to Puerto Rico ordered the construction of barracks for housing the soldiers in which adequate bedding--according to the conditions of the place--was to be provided. It stipulated that all soldiers in charge of guarding the barracks were to sleep in the barracks. The troops' quarters were to close at night until dawn.<sup>103</sup>

2. The army regulations of 1736 stipulated the uniforms and rations the soldiers were to receive. Also they indicated soldiers were to be provided with mattings for bedding.<sup>104</sup>

3. One author wrote that "The casemates of the San Diego Castle, in Acapulco...were 28 feet (10.5 *varas*) long. Twenty-two men slept in each...*petates*, or mattings, were placed over the sleeping platforms."<sup>105</sup> Assuming that the platforms extended along both 28 foot long walls, each soldier was allotted a sleeping space 30 inches wide.

4. Common soldiers were expected to occupy a space 34 inches wide on the wooden platform on which they slept.<sup>106</sup>

5. One eighteenth century progress report on the construction of La Princesa Fort in Puerto Cabello, Venezuela, stated: "The new barracks of this wooden fort can accommodate three companies. Their interior walls have been stuccoed and the barracks have been equipped with sleeping platforms for the troops, and wooden strips and wooden plugs to accommodate the common soldiers' knapsacks."<sup>107</sup>

6. Two braziers and two water jugs were furnished in the troops' quarters of a military installation in Valdivia, Chile, in 1760-62.<sup>108</sup>

7. It was estimated that 4,877 board feet of wood were required to repair the St. Augustine barracks in 1789. These repairs included the soldiers' platforms, gun racks, and knapsack racks. The thousand board feet of wood were estimated at 20 *pesos*. The soldiers' rack repairs required 300 L-shaped nails (*alcayatas*) also. One and one quarter-inch wood boards were required for repairing the racks, and two-inch boards for repairing the gun rack bases.<sup>109</sup>

8. The following carpentry work was needed for the St. Augustine barracks in 1788: 40 feet of two-inch board were required to construct an unspecified number of gun racks. The wood was estimated at 1.4 *pesos* and the labor 24 *pesos*. Fifty feet of half inch board and 600 L-shaped nails were required for making the soldiers' knapsack hangers and racks. Labor for the knapsack racks was estimated at 6 *pesos*.<sup>110</sup>

9. Thirty-six wood strips and an unspecified number of L-shaped nails were required for making the soldiers' knapsack racks at the St. Augustine barracks in 1789. Eighteen gun racks for 372 rifles, two wooden platforms for the use of the guards, and one for the guard sergeant were made also.<sup>111</sup>

10. An inventory made in 1789 listed the items found in the St. Augustine barracks located in the old St. Francis Convent. Besides two doors and 16 windows, the barracks had 36 strips of wood with L-shaped iron nails for hanging the common soldiers' knapsacks; 18 gun racks for 372 rifles, including those installed in the guard's quarters; two new platforms for the use of the guard soldiers; and one new platform for its sergeant<sup>112</sup>

11. Additional floor plans of three large troops' quarters illustrate the usage of wooden platforms for their bedding: the Santo Domingo barracks planned in 1757; the Santo Domingo barracks planned in 1760; and the cavalry barracks planned for Santiago, Chile, in 1764. The kitchens and latrines of the cavalry barracks are also shown in the Santiago plan.<sup>113</sup>

## Officers' Quarters

No definitive evidence was found relating to the quarters provided officers living in the barracks. Although comparative evidence was uncovered relating to furnishings of the officers quartered in guardhouses, it is unclear how much this relates to accommodations in the barracks. Generally speaking, accommodations for officers in the guardhouse would be more spartan than in the barracks because of the transitory nature of the assignment. Officers would be assigned duty in the guardhouse for only a short period of 24 hours at a time, then rotate out. The three large troops' quarters planned for Santo Domingo in 1757 and 1760 plus the cavalry barracks planned for Santiago, Chile, in 1764, do not contain detailed information on how the officers were to be accommodated there.

The following six historic references suggest the type of furniture found in officers' quarters. The references indicate what they slept on, what type of tables, benches, chairs, clothes racks, gun racks, and even candlesticks they used. The information given here contains the type of boards used for constructing the tables and the size of the tables also. Water jugs and a pedestal table were found in the officers' quarters on one occasion.

1. On September 9, 1797, an inventory was made of the contents of the guards' quarters in the San Gerónimo gunpowder warehouse in San Juan. This installation provided quarters for an officer, a sergeant, and the guards. The officer's room contained the following: one table with drawer, one bench with backing, one chair, one cot, one metal candlestick holder, two rings for hanging a hammock, a rack for clothes, a door with its lock, windows and their securing hardware. The document contains a detailed description of the windows, doors, and a wood wall.<sup>114</sup>

2. The following furniture was made in St. Augustine during 1786: one table, two benches, and one cot for the guard's officer; a wooden platform and a bench for the guard's sergeant.<sup>115</sup>

3. In 1790, the officers of the Third Infantry Battalion of Florida required the following pieces of furniture: two tables, five benches, four tubs, and four pitchers.<sup>116</sup>

4. In 1786, the artillery officers and troops of Florida requested 100 pair of shoes for the soldiers, two silver-colored metal candlesticks, two gold-colored metal candlesticks, 12 little packets of writing ink, and two boxes of tallow candles.<sup>117</sup>

5. The guard soldiers and officers of Florida required two tables and five benches in 1790. The one inch wood tables were to be 5 feet long and 2-1/2 feet wide. The legs of tables and benches were to be made of 2 by 2-inch wood.<sup>118</sup>

6. Two water jugs and one pedestal table are depicted in the floor plan of the officers' quarters in Valdivia, Chile.<sup>119</sup>

The interpretive planning team recommended eventually furnishing two rooms in the Officers' Quarters, one for junior officers, the other for senior officers, "when these spaces are vacated." Since little direct evidence is presently available on how officers were quartered in this type of fort, or on the furnishings associated with officers' quarters of the period, this report makes no recommendations on furnishings for the San Cristóbal Officers' Quarters.

### **Evidence of Uniforms and Equipment**

The portrait of Captain Don Ramon Caravajal of the Puerto Rican Fixed Regiment by Puerto Rican artist José Campeche is an excellent source of information. Painted soon after the British attack of 1797, this portrait depicts the captain in his field uniform with the Puerto Rican Regiment in the background right and the British in the background left (see Figure 17). The captain is wearing a military cocked hat with the red cockade of Spain on the left side, and a white regimental coat, probably of cotton or linen, with facings and standing fall collar or cape of blue material. There are only three large buttons on each lapel and the lapels appear to be false (non-working). The captain has a large silver epaulette on each shoulder. His waistcoat is of a slightly earlier period, as it is not squared off at the bottom, and his knee breeches have buckles. He wears top boots which do not reach the bottom of his knee breeches, thus showing three or four inches of silk stocking. He wears a waistbelt of tanned leather, with a silver belt buckle with what is probably a unit crest on the buckle. The belt contains two small pocket pistols on the left side along with a sword and scabbard. The sword is a silver hilted small sword with a silver sword knot. Finally, the captain is wearing a white linen shirt and stock and shows a bit of lace at the throat and cuffs.

The Puerto Rican Regiment in the background (see Figure 18 for enlarged detail) is wearing basically the same uniform. Their military cocked hats do not have piping or edging but they do have the red cockade of Spain. The men are wearing high linen or canvas gaiters with a black leather garter below the knee. Their equipment is carried on white buff leather crossbelts and they carry the Model 1752 Spanish musket. They do not appear to be carrying swords. It was common in all European armies of this period to eliminate all swords for enlisted men; non-commissioned officers continued to carry polearms instead of muskets.

Additional confirmation of this regiment's uniform is a single figure watercolor, done by José Campeche (see Figure 19). The soldier is wearing the same uniform as is shown in the painting (see Figure 17). The white regimental coat has a large blue standing fall collar, blue lapels fastened on each side of the coat with three large white metal buttons, and blue cuffs with three large

white metal buttons. The waistcoat is in the style of the period 1770-1785, longwaisted and not squared off at the bottom. It is not possible to tell if the knee breeches are hooked with buckles, buttons, or ties at the knee. The large, rectangular shoe buckles are of white metal. The red cockade of Spain is affixed to the military tricorne hat. There does not appear to be any piping on the edge of the hat, but it is cocked up with white cords.

Three period illustrations of Puerto Rican militiamen also painted by the local artist José Campeche, were discovered. The first painting (see Figure 20) shows a corporal of artillery, ca. 1785. His uniform differs from that of the regular troops in that it has white piping or trim on the hat. He wears a single-breasted regimental coat with no lapels. The collar and cuffs are red, a traditional artillery color. He wears brown leather narrow cross belts. His musket is the 1752 model; his cartridge box is of the type called a belly box, which was worn on a waist belt.

The second painting (see Figure 21) is of a period infantryman wearing a hat with white piping and a single-breasted regimental coat with red collar and cuffs without lapels. His buttons are grouped 1-2-3 beginning at the throat with bastioned lace. The cross belts are adjusted using brass buckles with a single tongue. He wears short black gaiters.

The third painting (see Figure 22) depicts a sergeant of artillery, his rank shown by the gold piping on the edge of his collar. He wears a single-breasted regimental coat with the buttons grouped 1-2-3. These button holes are laces in the brandenburg style, and are the same blue as the collar and cuffs. His crossbelts are dissimilar; one is white buff leather supporting a bayonet scabbard and the other is a narrow strap on which is suspended a vent pick. His cartridge box is a belly box on a waist belt. He wears buckled shoes and no gaiters.

## **Mess Rooms**

There is little direct evidence concerning mess table furnishings in Spanish colonial military installations, aside from the mention of 11 wood pitchers and 86 wooden dishes in the royal stores at San Juan in 1773<sup>120</sup>; and 110 dishes, 65 bowls, five small earthen casseroles, and eight medium size water vases in the Royal Hospital at San Juan. The hospital at St. Augustine, Florida, requested a complete set of pewter dishes and earthenware in 1790<sup>121</sup>.

Although three of the North Casemates (CM-3, CM-4, and CM-5) were designated "dining rooms" in the 1901 plan<sup>122</sup>, there is no earlier documentation for that use. It seems more likely that these casemates were used as troops' quarters and that the men ate their meals in the same rooms they slept in. Accordingly, furnishing one of these casemates specifically as a mess room is not recommended in this report. Instead, mess tables have been included in the furnishings of the Troops' Quarters (CM-5).

**FURNISHING PLAN**

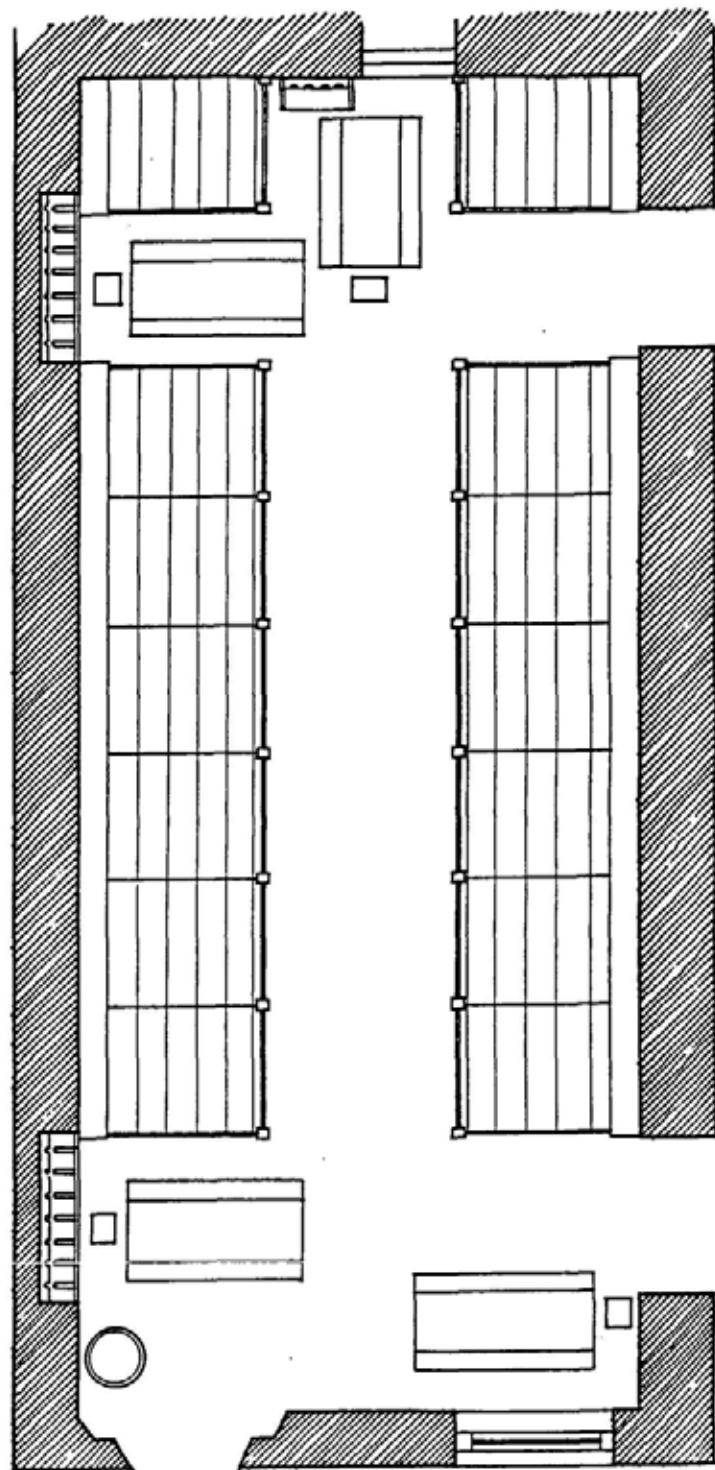

Troops' Quarters



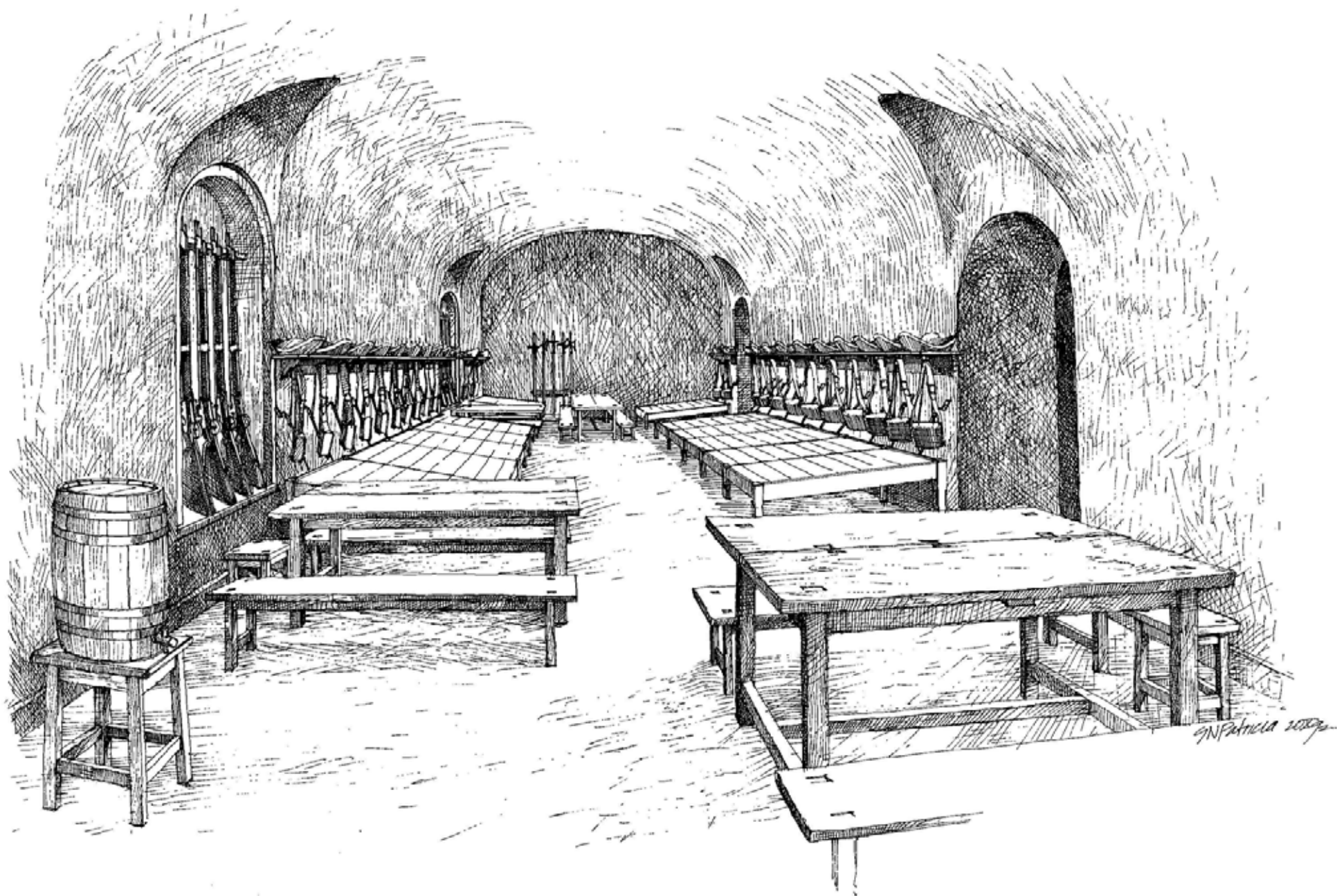

Troops' Quarters

## RECOMMENDED FURNISHINGS

### TROOPS' QUARTERS

Casemate CM-5 in the Troops' Quarters is to be furnished to the 1790-1800 period, when it housed 24 enlisted men and four non-commissioned officers of the Fixed Regiment of Puerto Rico. The occupants are out on duty for the day and the room's contents are neatly arranged, as if ready for inspection.

The following furnishings are recommended, all to be reproductions of 18th century Spanish or French colonial prototypes:

**Sleeping platforms for enlisted men (2).** The men slept on slanted, wooden platforms set into the north and south walls of the casemate, the head end a little higher than the foot. Each man had a space of 30 to 34 inches on the platform and provided his own mat or other cushioning. The platforms were supported by two rows of 3 inch x 1.5 inch wooden members, 50 inches apart, set into the wall at a height of 9 inches and 24 inches from the floor.<sup>123</sup>

**Sleeping platforms for non-commissioned officers (2),** placed on either side at the rear of the casemate. Similar to the preceding in construction, these smaller platforms provided sleeping space for four sergeants or corporals, two on each platform.

**Racks and peg boards (2),** along the full length of the north and south walls, above the sleeping platforms. The wooden rack or shelf provided a place to store clothes and personal belongings; the board below it was supplied with wooden pegs or large L-shaped nails, from which the men could hang their knapsacks (*mochilas*) and other personal effects.

**Gun racks (2),** placed in the openings on the north wall. These wooden racks will follow the general configuration of the vestiges of the original gun rack still in place on the west wall of the entrance of El Morro. See Figure 16.

**Mess tables (4),** 2 feet by 6 feet; two to be placed near the entrance and two at the far end of the room. See Figure 28.

**Benches (8),** 1 foot x 6 feet, backless, to be placed along the mess tables. See Figure 28.

**Stools (4),** 10 x 12 inches, one at the head of each mess table, for the use of a non-commissioned officer. See Figure 28.

**Rack for halberds (1),** on the floor against the rear wall, to hold non-commissioned officers' halberds.

**Uniforms and equipment** (28 sets), as follows:

- Military tricorn hat with red cockade
- Regimental coat, white with blue wool/linen facings
- Sleeved waistcoat, white linen
- Pair of breeches, white linen
- Pair of long gaiters, linen with black leather straps
- Pair of shoes, tied
- Stock, white linen
- Shirt, white linen
- Bayonet sling and scabbard, white leather
- Cartridge box and white leather sling
- Knapsack, linen with leather straps
- Wool blanket, brownish white

**Halberds** (4), to be placed in the halberd rack. See Figure 26.

**Muskets** (24), Spanish Model 1752, to be placed in the gun racks.

**Swords** (4) and **sword slings** (4), white leather, to be hung from pegs above non-commissioned officers' platforms.

**Mess equipment** (28 sets), to be placed on the mess tables, as follows:

- Metal plates
- Metal bowls
- Metal or horn spoons
- Earthenware cups

**Water jugs** (4), one on each table.

**Candlesticks** (4), earthenware, and **tallow candles** (4), one on each table.

**Water barrel and stand** (1), on the floor near the front door.

**Gorge**, for water barrel.

**Spit boxes** (4), wooden

**Drum**, with Spanish colors, **drum sling** and **drumsticks**, sitting on a bench next to one of the tables.

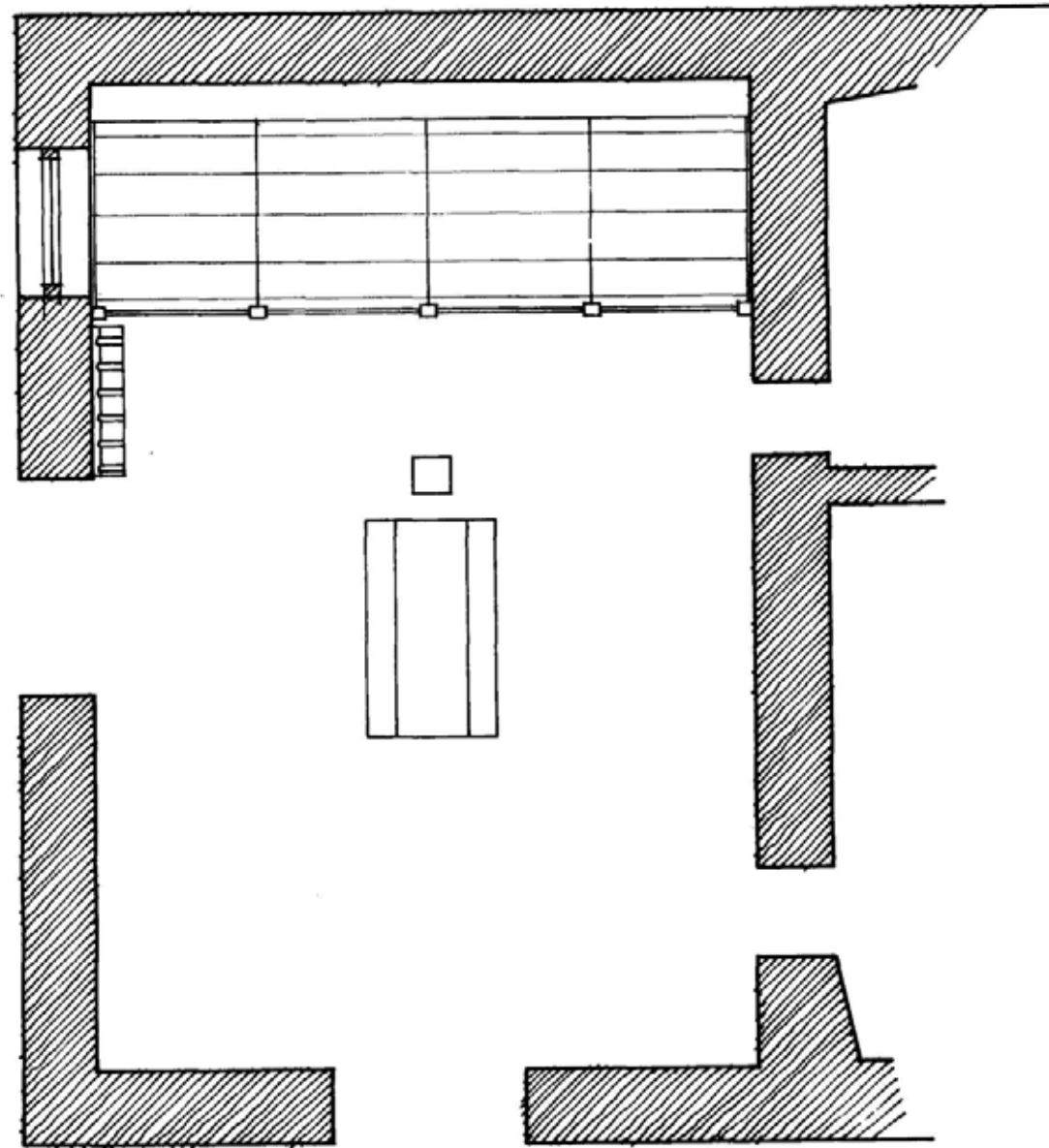

Guardhouse



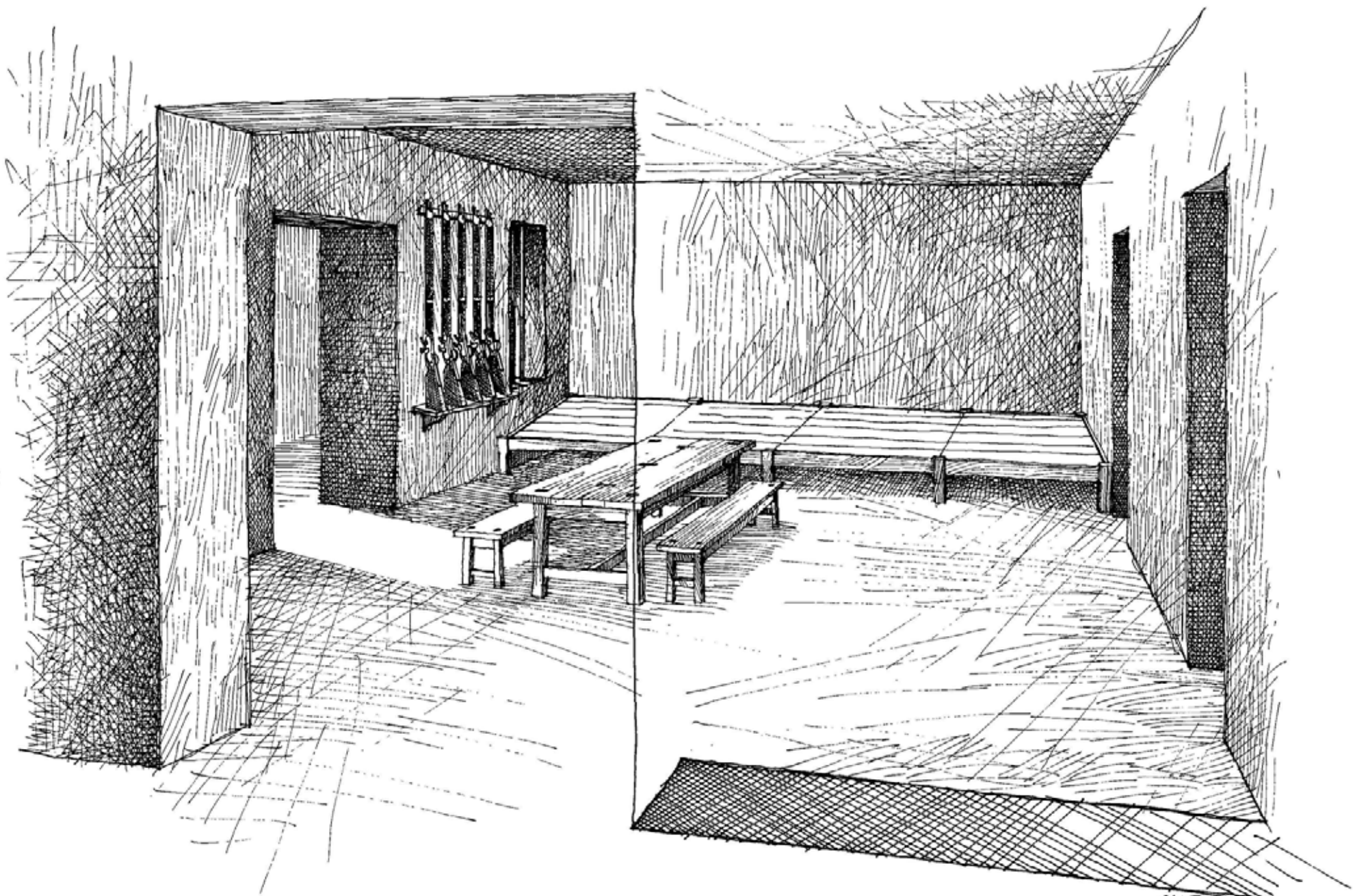

41

Guardhouse

*J. N. ... 2009*

## GUARDHOUSE AT THE NORTH CASEMATES

The furnishings of the south room in the Guardhouse at the North Casemates were similar to those in the Troops' Quarters, but more sparse, since the troops stayed there for only brief periods. Originally this room was divided in half by a solid partition (not removed until about 1963); one section housed the enlisted men and a sergeant; presumably the officer of the day occupied the other. Two smaller rooms opening off the north side of the guardhouse were added about 1861; at least one of these served as a cell for prisoners.

The west side of the south room will be partially furnished, with a sleeping platform along the west wall and a gun rack with two muskets on the south wall to the left of the door. In the center of this space will stand a fully uniformed mannequin in a glass exhibit case. The other half of the room, to the right of the door, will contain displays interpreting the story of the Puerto Rican Regiment.

Recommended Furnishings, all reproductions of Spanish colonial prototypes:

**Sleeping platform** (1) for enlisted men of the guard, along the west wall; similar to platforms in the Troops' Quarters.

**Gun rack** (1), affixed to south wall, west of entrance.

**FURNISHINGS MAINTENANCE AND PROTECTION  
RECOMMENDATIONS AND PROCEDURES**

A supplementary section of this report, containing site-specific recommendations and procedures for the maintenance and protection of the exhibited furnishings, will be issued separately following installation of the furnishings.

## NOTES

1. The original of O'Reilly's report is in the Archivo General de Indias, Seville, Spain, hereafter cited as AGI. The citation of the complete document is AGI Santo Domingo 2501, and a printed transcription is found in Alejandro Tapia y Rivera, ed., *Biblioteca histórica de Puerto Rico* (San Juan, 1970), pp. 624-49. For a resume of this report plus the contents of O'Reilly's letters to the Marquis de Squillace and the Marquis de Grimaldi, see Altagracia Ortiz, *Eighteenth-Century Reforms in the Caribbean; Miguel de Muesas, Governor of Puerto Rico 1769-76* (East Brunswick, NJ, 1983), pp. 81-96. In addition to O'Reilly's report, there are six contemporary sources describing in some detail the very limited material and cultural resources available in Puerto Rico during the second half of the eighteenth century. They are: Report of Thomas O'Daly upon his arrival in Puerto Rico, in AGI Santo Domingo 2501; Andrés Vizcarrondo, "Informe de Visita a Varios Partidos de la Isla, 5 April 1770," in AGI Santo Domingo 2300; Fernando Mirayes González, *Noticias particulares de la isla y plaza de San Juan Bautista de Puerto Rico* (Río Piedras, PR, 1954), written in 1775; Iñigo Abbad y Lasierra, *Historia geográfica, civil, y natural de la isla de San Juan Bautista de Puerto Rico* (Río Piedras, PR, 1959), written in 1782; André Pierre Ledrú, *Viaje a la isla de Puerto Rico en el año de 1797* (Río Piedras, PR, 1957); and "Informe Visita Pastoral Obispo de Puerto Rico," written by Bishop Cengotita, 1797, in AGI Santo Domingo 2522.
2. O'Daly's construction reports to the king are found in AGI Santo Domingo 2301, 2503, 2504, 2506, and 2510. The earliest is from June 1769 and the latest from June 1779; see **Documents** under the heading **BIBLIOGRAPHY**.
3. See "The Fortifications of San Juan National Historic Site: Historic Structure Report, Vol. II: El Fuerte de San Cristóbal" (1991) by the Building Conservation Branch of the Cultural Resource Center, North Atlantic Region, National Park Service, as follows: for the history of the North Casemates structures, Chapter 2; for the Guardhouse at the North Casemates, Chapter 3; for the Officers' Quarters, Chapter 7; for the Troops' Quarters, Chapter 9.
4. Royal decree cited by Juan Marchena Fernández, *Oficiales y soldados en el ejército de América* (Seville, 1983), p. 271.
5. Juan Marchena Fernández, *La institución militar en Cartagena de Indias 1700-1810* (Seville, 1982), p. 48.
6. For this and the next paragraph, see AGI Santo Domingo 2499-8 to -15. The *Reglamento*, found in 2499-9 to -12, was printed also; see *Reglamento para la guarnición de la plaza de Puerto Rico, castillos y fuertes de su jurisdicción* (Madrid, 1741).
7. The Governor's letter is found in AGI Santo Domingo 2499-14; the quarters for



the Fixed Battalion are specified in the part of the 1741 Regulation found in AGI Santo Domingo 2499-11.

8. AGI Santo Domingo 2501-20 and -21. O'Reilly's report to the King dated June 24, 1765, has been transcribed by Bibiano Torres Ramírez, *La isla de Puerto Rico (1765-1800)* (San Juan, 1968), pp. 299-303. Torres, however, lists a different reference: AGI Santo Domingo 2395. Also see Bibiano Torres Ramírez, *Alejandro O'Reilly en las Indias* (Seville, 1969), pp. 55-71.

9. Included in AGI Santo Domingo 2501-21.

10. Marchena, *Oficiales y Soldados*, p. 272, states that recruitment in the Indies began with the formation of the Fixed Battalions under Philip V. Marchena adds that prior to that time--which for Puerto Rico is 1741--Spain had the "monopoly" in recruiting soldiers for service in the Indies.

11. Numerous local recruits are found in Cuba and Mexico during the earlier part of the eighteenth century also. October 1991 telephone conversation with René Chartrand, Chief Curator, Canadian Park Service, Ottawa.

12. Marchena, *Oficiales y Soldados*, pp. 288 to 289.

13. *Ibid.*, pp. 275-278.

14. Archivo y gobierno de capitania de Venezuela, XXX, 85, cited by Santiago Gerardo Suárez, *Instituciones militares venezolanas del periodo hispánico en los archivos*, (Caracas, 1970), p. 388. Marchena, *Oficiales y Soldados*, p. 297 and his Note No. 7.

15. Marchena, *Oficiales y Soldados*, pp. 296-306. Some minor arithmetical errors found in Marchena's table on page 300 have been corrected in Table 4.

16. *Ibid.*, p. 317.

17. Respectively in AGI Santo Domingo 2502, 2502, 2505-111, 2505-114.

18. The complete report is included in AGI Santo Domingo 2506A- 1 to -3. Part of this report is found in AGI Santo Domingo 2501 also.

19. This review gives an idea of the composition and size of the Victoria Regiment. It was made of two battalions, each composed of nine companies, plus a staff (*estado mayor*). The first battalion was made of a company of grenadiers which on that date had 63 men, and eight companies of fusiliers having each 63, 66, 64, 64, 63, 63, and 64 men respectively. The second battalion was made of a company of grenadiers with 63 men, and eight companies of fusiliers with 67, 64, 64, 64, 63, 64, and 63 men respectively. The number of the regimental officers, sergeants and corporals was as follows: 14 captains (plus 1 in Spain and 3 vacant); 14 lieutenants (plus 1 in Spain and 3 vacant); 14 sublieutenants (plus

2 in Spain, 1 suspended, 1 vacant); 18 first sergeants; 32 second sergeants (2 in the hospital); 47 first corporals (2 in the hospital); 56 second corporals (1 in the hospital); and 34 drummers (1 in the hospital). Since the number of active men listed in this regiment is given in the document as totalling 1,169, a good number of soldiers' positions were vacant in addition to the 19 soldiers listed as being in the hospital. The composition of the Bruselas Regiment--recently arrived in Puerto Rico--is also described in the document. It had the same number of battalions and companies but the number of active men was 1,351.

20. AGI Santo Domingo 2506B-11.

21. Ibid., 2507-20, -21, -22. The troops review dated January 1779 is in AGI Santo Domingo 2507-24.

22. Ibid., 2508-30 and 2509-31.

23. Ibid., 2509-33 and -35.

24. Robert Taylor, *Catalog of the José Campeche Exhibition in the Ponce Museum and in the New York Metropolitan Museum, 1989* (New York, 1989), p. 167. This reference was given to me by Mr. René Chartrand, Chief Curator, Canadian Park Service, Ottawa.

25. Archivo General de Simancas (AGS) G. M. Legajo 7289 C 6.

26. AGI Santo Domingo 2510-45.

27. Alejandro O'Reilly, "Reglamento Para la Tropa Veterana de Puerto Rico," 27 April 1765, in AGI Santo Domingo 2395.

28. The enlisted mens' barracks in San Cristóbal consist of a two-story building containing eight rectangular rooms of essentially the same dimensions. The longer sides of the rectangles consist of walls and connecting passageways, and the shorter sides have mostly windows. As will be demonstrated later in this report, the headboards of the platforms on what the soldiers and corporals slept were affixed to the walls along the longer sides of the rectangles only, leaving the passageways free for foot traffic. The longitudinal wall space against which the sleeping platforms were affixed, measures approximately 800 inches in each of the eight rooms of the barracks. As will be demonstrated in this report later, also, each soldier was allowed a sleeping space around 30 to 34 inches wide. If the 800 total available inches are divided by 30 (the smallest allotted space per soldier) the result is that 27 soldiers could fit in each room, and 216 men could, therefore, fit in the eight rooms of the barracks. Only single soldiers were to live in the barracks and the Victoria Regiment had about 1150 soldiers. Considering that, on the average, 40 percent of the soldiers were single (Marchena, *Oficiales y Soldados*, p. 317) 460 Victoria soldiers were eligible for the barracks; of these, 216 were housed in them and the rest in whatever accommodations were available in El Morro or were secured in town. In addition, each of the barracks' rooms has

enough free wall space to accommodate two headboards close to the windows with view of the Plaza. Two sergeants could sleep in these beds per room, 16 sergeants in all. Since one regiment had 18 first class and 32 second class sergeants--about half of them single--the eight rooms could conceivably provide housing for about two-thirds of all the regiment's single sergeants.

29. "San Juan National Historic Site, Historic Structures Report, Vol. II," pp. 35 and 39. The seven casemates, each about 394 inches long, could accommodate soldiers' sleeping platforms along both of the long walls. Disregarding the doorways in the partition walls, if a 30-inch sleeping width is allowed per soldier, each casemate could accommodate 26 men and all seven could fit 182 soldiers. Since a battalion was composed of about 600 men it is clear that not all of them could fit into the seven casemates, even when allowing that single soldiers only lived in the casemates, and that about 40 percent of the soldiers of the battalion were single.

30. In regard to the soldiers living in the bishop's houses, see historical source number 2 under subtitle **Latrines** in EVIDENCE OF FURNISHINGS. The other two documents mentioned are dated January 4 and January 18, 1768, and they are signed by Don José de Pedraza; see AGI Santo Domingo 2502.

31. Marchena, *Oficiales y Soldados*, pp. 323 and 324.

32. For one detailed description of soldiers' rations see AGI Santo Domingo 2502. Military regulations dated May 8, 1795, stipulated the obligations of the *Guardalmacén de Víveres* and the soldiers' rations that varied from day to day: Wednesdays and Fridays were fish days; see Antonio Vallecillo, *Ordenanzas de Su Magestad para el régimen, disciplina, subordinación, y servicio de sus ejércitos*, 3 vols. (Madrid, 1851), vol. II, pp. 321-323.

33. Alvaro Navia Osorio, *Reflexiones militares*, 11 vols. (Paris, 1724-173, vol. 11 (Libro 21 capítulo XV), p. 254; AGI Santo Domingo 2503, document dated 12 February 1769 in San Juan; Albert Manucy and Ricardo Torres-Reyes, *The Forts of Old San Juan* (Riverside, CT, 1973), p. 21.

34. See historical sources numbered 12 and 22 under **Kitchens** in EVIDENCE OF FURNISHINGS section.

35. AGI Santo Domingo 2502, document dated in San Juan, January 18, 1768. The signer, Marior de Vergara, indicated that the companies of the León Regiment have their own cooking pots and cooking utensils.

36. *Ibid.*, 2310, "Relación de las embarcaciones que entraron en 1790 al puerto de San Juan."

37. The CM numbering system used in this report to identify spaces in the San Cristóbal casemates was devised by the Historic American Buildings Survey for its 1963 set of drawings of San Cristóbal. These numbers were also used in

HSR, Vol.II: San Cristóbal; it should be noted, however, that in fig. 9.5 the casemate numbers in the Troops' Quarters were inadvertently reversed, CM-1 appearing as CM-5, CM-2 as CM-4, CM-4 as CM-2, and CM-5 as CM-1.

38. Ibid., p. 48 and fig. 214; see also Figure 1 of this report.

39. Ibid., p. 79, fig. 3.6.

40. The 1861 plan and elevations of North Casemates by Manuel Castro, San Juan National Historic Site archives.

41. *Actas del cabildo de San Juan Bautista de Puerto Rico* (San Juan, 1949-1978: a) Book 1767-1771, p. 222; b) Book 1767-1771, p.159; c) Book 1771-1778, p. 130; d) Book 1782-1785; e) Book 1803-1809, p. 54; f) Book 1803-1809, pp. 294-5 and 323-4.

42. María de los Angeles Castro, *Arquitectura en San Juan de Puerto Rico (siglo XIX)* (Río Piedras, PR, 1980), p. 145.

43. Page 25 of the floor plans listed in Servicio Geográfico del Ejército, *Cartoteca histórica* (Madrid, 1974), p. 104.

44. Cristina Campo Lacasa, *Notas generales sobre la historia eclesiástica de Puerto Rico en el siglo XVIII* (Seville, 1963), between p. 72-73.

45. From plan page 29 described in Servicio Geográfico del Ejército, *Cartoteca histórica* (Madrid, 1974), p. 104.

46. EF bnd 170A14, December 31, 1788.

47. Ibid., December 31, 1787.

48. EF bnd 171B14, December 31, 1790.

49. Ibid., December 31, 1792.

50. EF bnd 277o14, May 20, 1789.

51. Ibid., May 25, 1791.

52. Figures 11-15; see also "Fortifications of San Juan National Historic Site, Historic Structures Report," Vol. II, p. 48,

53. Ibid., p.75, fig. 3.5.

54. Ibid., p. 79, fig. 3.6.

55. Alvaro Bazan, *Archivo Naval*, ca. 1830, p.31; quoted in "The Fortifications of San Juan NHS, HSR" Vol. II, p. 42.

56. Rafael Clavijo, report dated February 27, 1859; quoted in "The Fortifications of San Juan NHS, HSR," Vol. II, p. 44.
57. Memorandum from Chief, Cultural Resources Center, North Atlantic Region, NPS, to Chief, Division of Historic Furnishings, Harpers Ferry Center, NPS, June 19, 1992.
58. Ibid., 2502. The reason for taking this inventory is not given in this document dated Puerto Rico, August 2, 1768, and signed by José Antonio Gelabert. The complete 28-page inventory covers the following: San Cristóbal cannons; gunpowder at the Santa Bárbara store; all the contents of the Concepción store including tools for loading and operating the cannons, caulking materials, naval stores, crude iron and iron tools and implements, other tools, bronze and copper goods, lead, nails, other provisions for the artillery, paints, tools and other implements used by the artillery battalion, carpentry tools; materials and others used in the royal works including carpentry tools, boards and other woods, iron and steel, nails, tools and other utensils; foundry; boats; canoes; kitchen utensils; church ornaments; contents of the Royal Hospital in San Juan, including apothecary's implements and books; contents of the Fortaleza (Governors' residence) chapel; Royal Ranch located in Río Piedras including its land, house, and cattle; two houses used to quarter troops and forced men located "in front of the San Juan Plaza."
59. Ibid., 2512-36.
60. Campo Lacasa, *Notas generales*, between pp. 72-73. The plan of this hospital is also shown in Cristina Campo Lacasa, *Historia de la iglesia en Puerto Rico (1511-1802)* (San Juan, 1977), and in María de los Angeles Castro, *Arquitectura*.
61. Campo Lacasa, *Notas generales*, between pp. 96-97.
62. Altagracia Ortiz, *Eighteenth Century Reforms in the Caribbean* (East Brunswick, NJ, 1983), pp. 142-143.
63. AGI Santo Domingo 2510-50, referring to Juan F. Mestre's 1783-84 report.
64. Ricardo Alegría, *El fuerte de San Gerónimo del Boquerón* (San Juan, 1969), p. 62.
65. Abbad y Lasierra, *Historia geográfica*, p. 99.
66. Ledrú, *Viaje a la isla de Puerto Rico*, pp. 111-12.
67. Gasparini, *Las fortificaciones del período hispano en Venezuela*, p. 229.
68. Page 25 floor plan identified in Servicio Geográfico del Ejército, *Cartoteca histórica*, p. 104.

69. José Antonio Calderón Quijano, *Historia de las fortificaciones en Nueva España* (Seville, 1953), fig. 118.
70. Graziano Gasparini, *La casa colonial venezolana* (Caracas, 1962), p. 156.
71. Graziano Gasparini, *La arquitectura colonial de Coro* (Caracas, 1961), p. 210.
72. Juan Manuel Zapatero, *Historia de las fortificaciones de Puerto Cabello* (Caracas, 1977), p. 160.
73. Vicente Rodríguez Casado and Florentino Pérez Embid, *Construcciones militares del Virrey Amat* (Seville, 1949), p. 228.
74. Ann P. Emerson, "Standards of Nutrition in a St. Augustine Hospital, 1783-1821," in *Florida Historical Quarterly*, 65:2 (October 1986), p. 148.
75. Albert Manucy and Ricardo Torres-Reyes, *Puerto Rico and the Forts of Old San Juan* (Old Greenwich, CT, 1973), p. 21.
76. Albert Manucy, *The Houses of St. Augustine* (St. Augustine, FL, 1962), p. 124.
77. EF bnd 170A14, December 31, 1786.
78. Page 29 plan described in Servicio Geográfico del Ejército, *Cartoteca histórica*, p. 104.
79. "The Fortifications of San Juan NHS, HSR," Vol. II, p. 49 and figs. 14-15.
80. *Ibid.*, pp. 44-49, including figure 2.14.
81. *Actas del cabildo de San Juan Bautista de Puerto Rico* (San Juan, 1949-1978); see the index of each volume covering the period 1780-1800.
82. See "The Fortifications of San Juan NHS, HSR," Vol. II, pp. 68-84 and 172-174.
83. Altogracias Ortiz, *Eighteenth Century Reforms in the Caribbean* (East Brunswick, NJ, 1983), pp. 142-143.
84. AGI Santo Domingo 2503.
85. *Ibid.*, 2506A-4.
86. Leonardo Rodríguez Villafañe, *Catálogo de mapas y planos de Puerto Rico en el Archivo General de Indias* (San Juan, 1966), p. 72-73.
87. Calderón, *Historia de las fortificaciones en Nueva España*, fig. 114.
88. *Ibid.*, fig. 99.

89. AGI Mapas y Planos, Venezuela 141.
90. Rodríguez and Pérez, *Construcciones militares*, p. 203.
91. *Ibid.*, p. 184.
92. EF bnd 170A14, December 31, 1785.
93. *Ibid.*, December 31, 1784.
94. EF bnd 171B14, December 31, 1790.
95. *Ibid.*, December 31, 1791.
96. *Ibid.*, June 30, 1800.
97. EF bnd 277o14, May 20, 1789.
98. *Ibid.*, October 14, 1790.
99. *Ibid.*, October 14, 1790.
100. *Ibid.*, May 25, 1791.
101. *Ibid.*, May 16, 1792.
102. Memorandum from Chief, Cultural Resources Center, North Atlantic Region, NPS, to Chief, Division of Historic Furnishings, Harpers Ferry Center, NPS, June 19, 1992.
103. AGI Santo Domingo 2499-67, folio 13. This document was printed with the following title: *Reglamento para la guarnición de la plaza de Puerto Rico, castillos, y fuertes de su jurisdicción* (Madrid, 1741).
104. Juan Marchena Fernández, *Oficiales y soldados*.
105. Calderón, *Historia de las fortificaciones*, p. 240.
106. Calculated from the plan shown by Rodríguez and Pérez, *Construcciones militares*, p. 230.
107. Zapatero, *Historia de las fortificaciones de Puerto Cabello*, p. 160.
108. Rodríguez and Pérez, *Construcciones militares*, p. 203.
109. EF bnd 170A14, July 31, 1789.
110. *Ibid.*, October 31, 1788.

111. Ibid., December 31, 1789.
112. EF bnd 277o14, May 20, 1789.
113. Their respective citations are: Servicio Historico Militar, *Cartoteca histórica*, p. 104; Rodríguez and Pérez, *Construcciones militares*, p. 235-236.
114. AGI Santo Domingo 2503.
115. EF bnd 170A14, December 31, 1786.
116. EF bnd 158B13, March 9, 1790.
117. EF bnd 166, June 1, 1786.
118. EF bnd 171B14, March 16, 1790.
119. Rodríguez and Pérez, *Construcciones militares*, p. 203.
120. AGI Santo Domingo 2512-36.
121. EF bnd 171B14, March 4, 1790.
122. "The Fortifications of San Juan NHS, HSR," Vol. II, fig. 2.17.
123. Evidence of the wooden members affixing the platforms to the walls is still visible in casemate CM-1. Evidence recorded in December 1990.



**ILLUSTRATIONS**

Figure 1.

Plans and elevations of North Casemates, San Cristóbal, drawn by Manuel Castro, 1861. *N* represents kitchens (*Cocina*). *O* represents latrines (*Lugar Comun*). San Juan National Historic Site archives.

Quinta propuesta para las Compañías  
de Soldados Guaraní

- A. Calle de Traves de la iglesia
- B. Plaza delante de el. Real
- C. Calle principal y Calle de Sanabria al porvenir
- D. Lugar para el oficio de Parada de Armas
- E. Lugar para el Colegio
- F. Almacenes para la Arma de Soldados
- G. Plaza
- H. Salas de Almacenes
- Y. Plaza principal y Iglesia
- J. Lugar para el Real
- K. Plaza para el Armas de Caballería
- L. Lugar para el Armas de Infantería
- M. Almacenes de víveres y herramientas
- N. Casa
- O. Lugar para el Real

La disposición del Armas con Armas de Caballería (en el  
mismo lado Y. H. según se muestra en la propuesta de esta  
línea. Se han asignado los Comandos mandados al Armas de  
según el orden siguiente para las Compañías de Armas

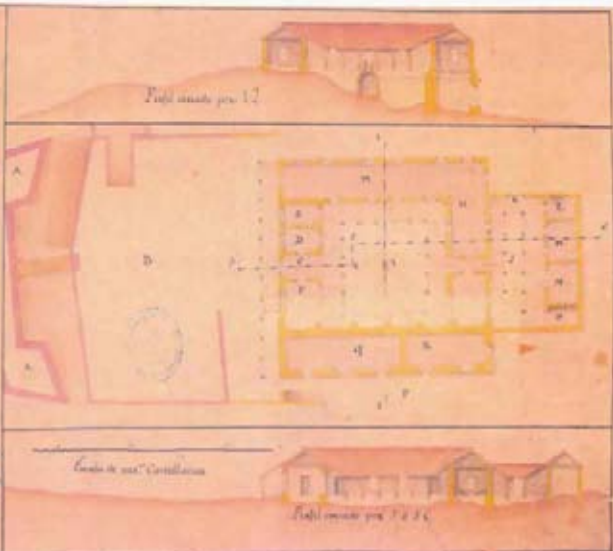
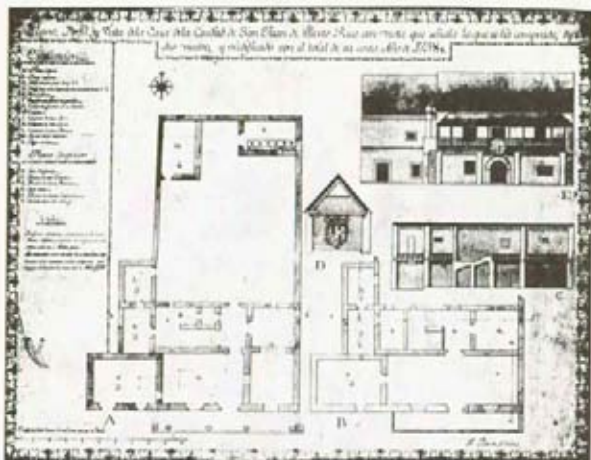

Figure 2.

Plan of Casa de la Ciudad (Government House), San Juan, Puerto Rico, 1758. From Maria de los Angeles Castro, *Arquitectura en San Juan de Puerto Rico (siglo XIX)* (University of Puerto Rico, 1980), p. 145.



F = Guard officer's room

G = Guard soldiers' room with its platform

N = Latrine

Figure 3.

Latrine rooms and kitchens of Santo Domingo barracks planned in 1757. Details from page 25 of the floor plans listed in Servicio Geográfico del Ejército, *Cartoteca historica* (Madrid, 1974), p. 104.

Detail 1. Latrine rooms

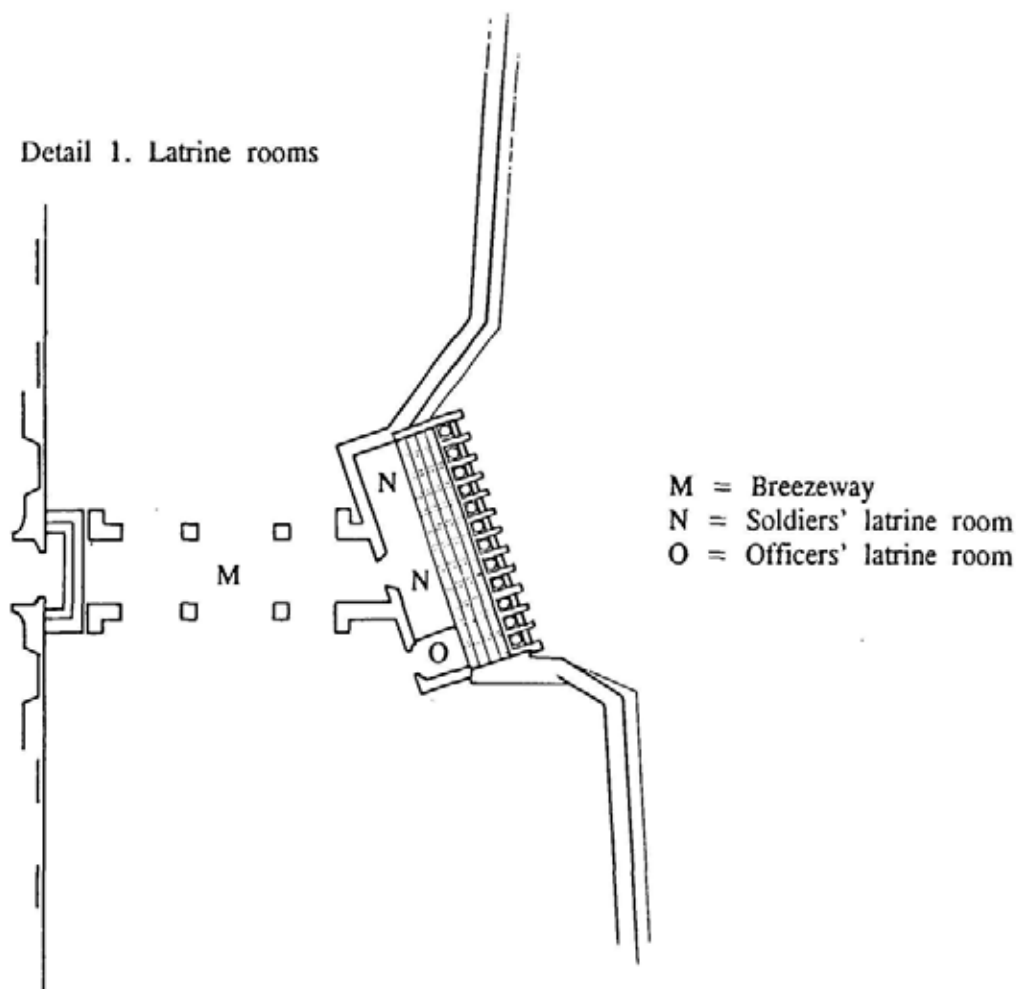

Detail 2. Kitchens

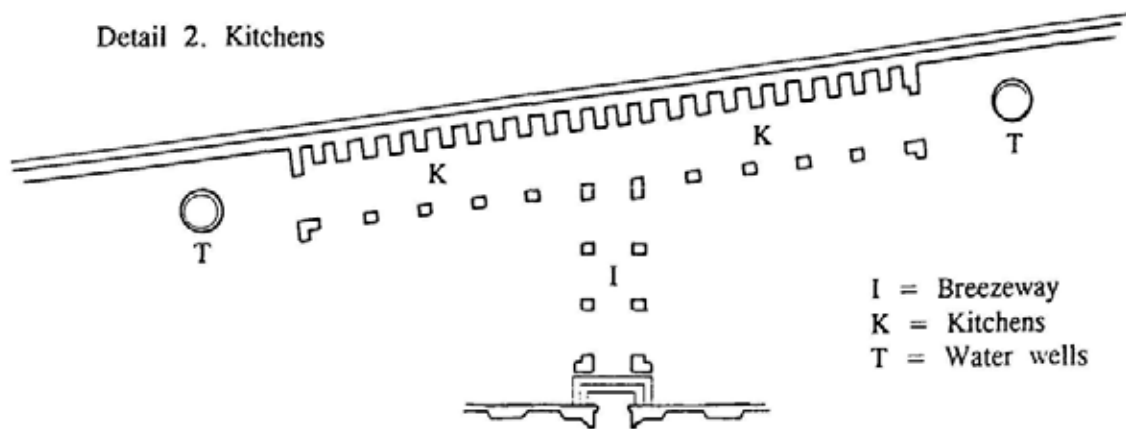

Figure 4.

Plan of first floor of Charity Hospital, San Juan, Puerto Rico, 1778. From Cristina Campo Lacasa, *Notas generales sobre la historia eclesiastica de Puerto Rico en el siglo XVIII* (Seville: Instituto de Cultura Puertorriqueña, 1963), p. 72.



PLANO DEL PISO INFERIOR DEL HOSPITAL DE CARIDAD DE P.R.

ESPLICACION.

A. Capilla.  
 B. Claustro.  
 C. Entrada principal.  
 D. Aposento de la Botica.  
 E. Botica.  
 F. Cocina y Almacén.  
 G. Comedor y Calina.  
 H. Sala de Baños.  
 Y. Sala de Baños de las Señoras.  
 V. Sala de Baños de los Señores.

I. Entrada de la Capilla principal.  
 M. Cocina para el Hospital y Botica.  
 N. Almacén para el Hospital.  
 O. Botica.  
 P. Comedor.  
 Q. Almacén para el Hospital.  
 R. Sala para el Hospital.  
 S. Almacén para el Hospital.  
 T. Espedite de Calentamiento.  
 V. Sala que al lado de la Capilla.

**NOTA.**  
 Que las líneas de este Plano trazadas del camino mas arriba en las que pone el Rey, junto con las que pone de Cruz, de Armas y de España, la Cruz y de los Señores del Hospital, están a la disposición del Placer de los Señores.

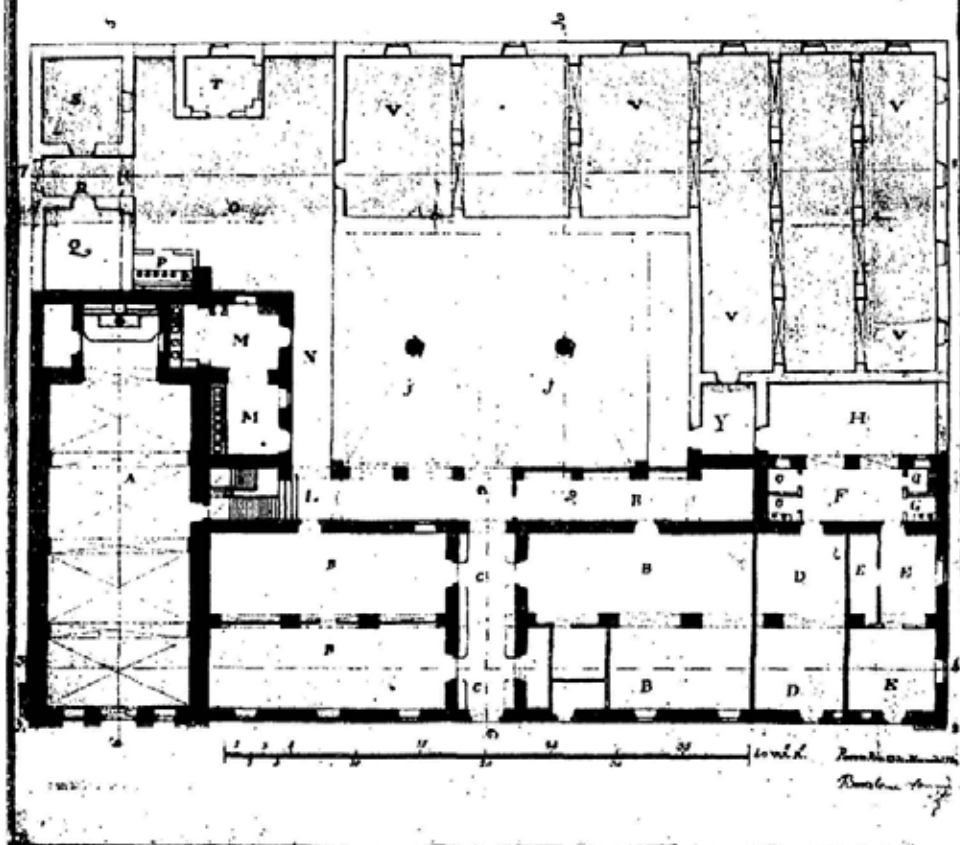

G = Latrines and Kitchens

M = Hospital kitchen and apothecary

P = Latrine

Figure 5.

Plan of second floor of Charity Hospital, San Juan, Puerto Rico, 1778. From Cristina Campo Lacasa, *Notas generales sobre la historia eclesiastica de Puerto Rico en el siglo XVIII* (Seville: Instituto de Cultura Puertorriqueña, 1963), p. 72.

Explicacion del Plano

Plano Sexto que iguala al principal

- A. Capilla.
  - B. Sala alta y baja para el Comedor.
  - C. Sala baja para las Comedoras, y alta para las Regidoras.
  - D. Conserjería.
  - E. Oficina alta y baja para el Alcaide.
  - F. Secretaría.
  - G. Sala alta para el Consejo de Camarera, y baja para el de Justicia.
  - H. Cocina y Refectorio.
  - I. Puerta.
  - M. Clavos altos y bajos.
  - N. Estada principal de la Sala.
  - O. Escalera.
- Plano de la Sala principal que se ve en la linea 3 y 2. Perfil en la linea que pasa por la linea 3 y 2. Perfil en la linea que pasa por la linea 3 y 2.

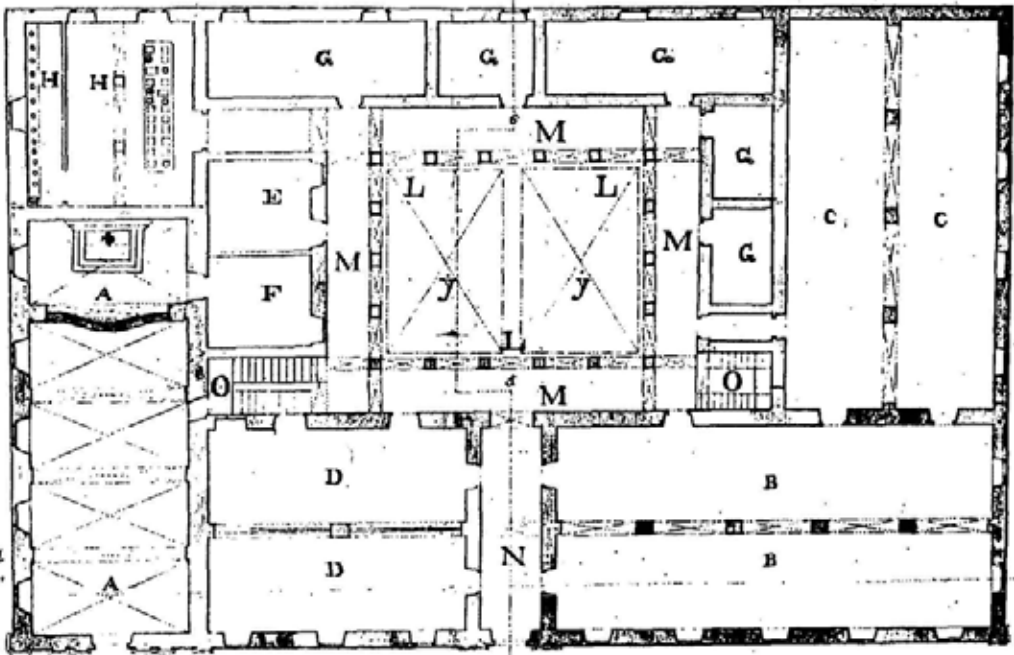

Cocina del Plano y Perfil de documentos nuevos y reales

H = Kitchen and refectory

Figure 6.

Latrine room (*lugares comunes*) planned in 1760 for Santo Domingo barracks. Servicio Geográfico del Ejército, *Cartoteca historica* (Madrid, 1974), p. 104 and plan p. 29.

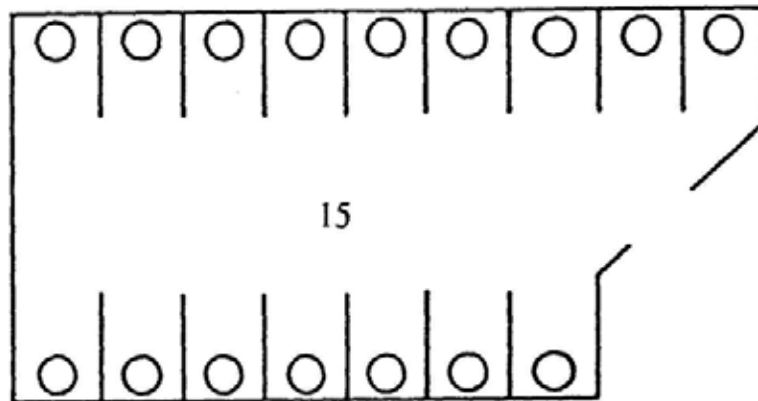

15 = Latrines

Figure 7.

Plan of Batería de San Luis at Campeche, Mexico, 1792.  
From José Antonio Calderon Quijano, *Historia de las  
fortificaciones en Nueva España* (Seville, 1953), fig. 118.

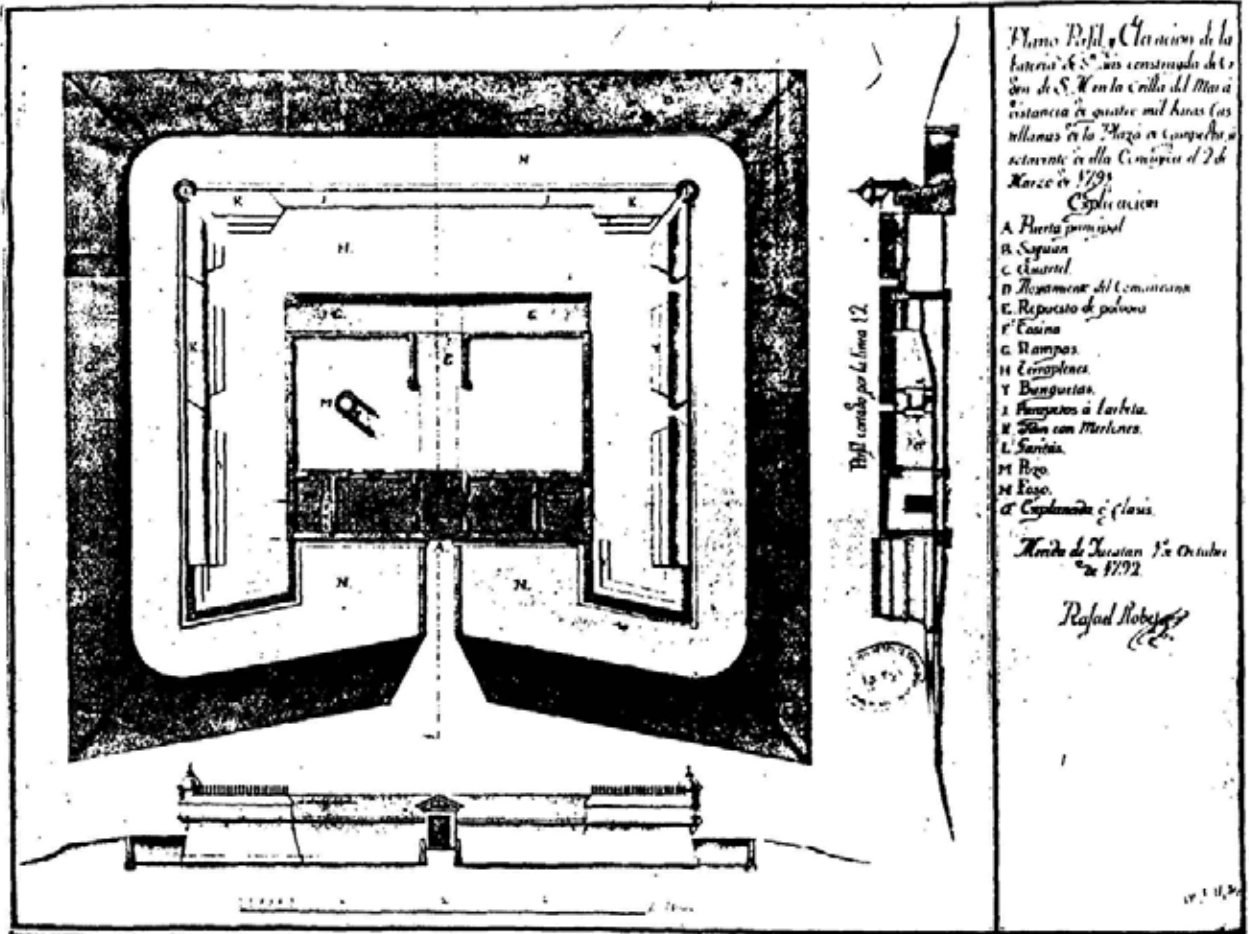

Plano Perfil y Clavacion de la  
 cocina de S. Mateo construida de  
 orden de S. Mateo en la Villa del Mar a  
 instancia y gastos del Sr. D. Juan  
 de S. Mateo en la Plaza de Compostela  
 situada en la Calle de Compostela el 2 de  
 Marzo de 1772.

- Explicacion
- A. Puerta principal
  - B. Sazon
  - C. Alacena
  - D. Alojamiento del Comensal
  - E. Repuesto de pavos
  - F. Cocina
  - G. Rampas
  - H. Comedores
  - I. Bueguetas
  - J. Puercos a la brasa
  - K. Seta con Martines
  - L. Surtida
  - M. Fogo
  - N. Esco.
  - O. Capitanada e' claus.

Hecho de Jucatan 1.º de Octubre  
 de 1772.

Rafael Robey

F = Kitchen

Figure 8.

First floor plan of projected Seminary, San Juan, Puerto Rico, 1712. From Cristina Campo Lacasa, *Notas generales sobre la historia eclesiastica de Puerto Rico en el siglo XVIII* (Seville: Instituto de Cultura Puertorriqueña, 1963), p. 96.



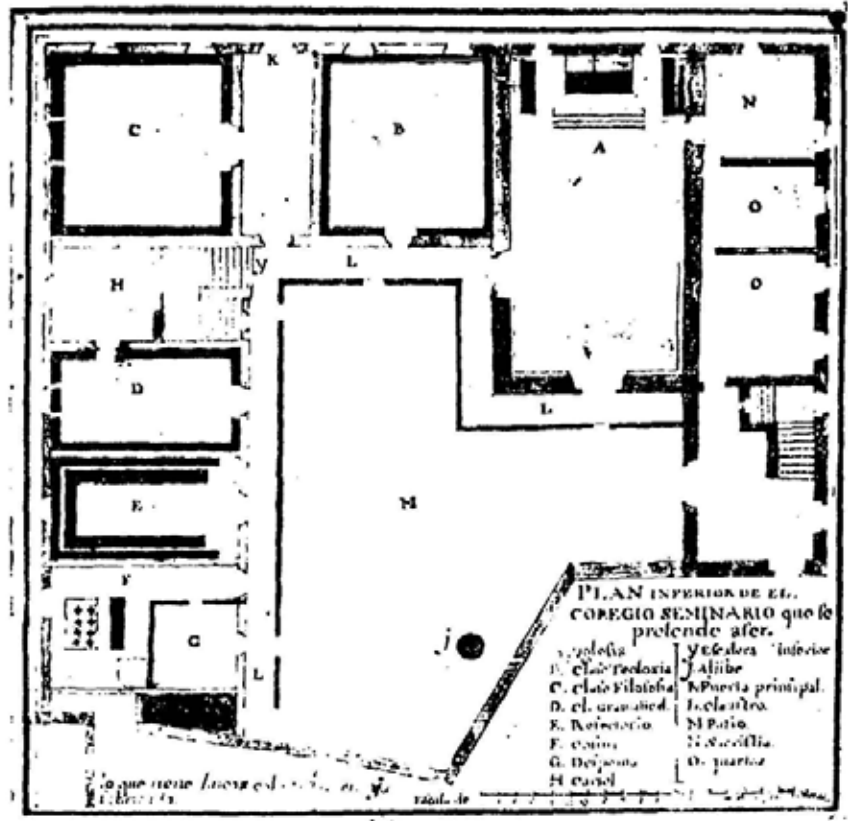

E = Refectory

F = Kitchen

G = Pantry

Figure 9.

Reconstructed colonial Venezuelan house kitchen, Museo de Arte Colonial de Caracas. From Graziano Gasparini, *La casa colonial venezolano* (Caracas: Centro Estudiantes de Arquitectura, Universidad Central de Venezuela, 1962), p. 156.

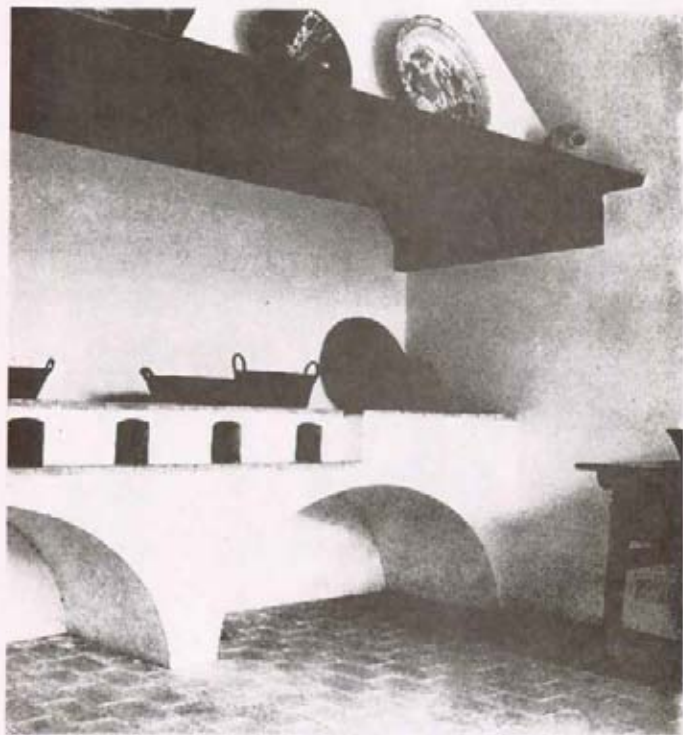

Figure 10.

Floor plan of a colonial house in Coro, Venezuela. The kitchen is located in the upper left corner in front of the patio. From Graziano Gasparini, *La arquitectura colonial de Coro* (Caracas, 1961), p. 210.

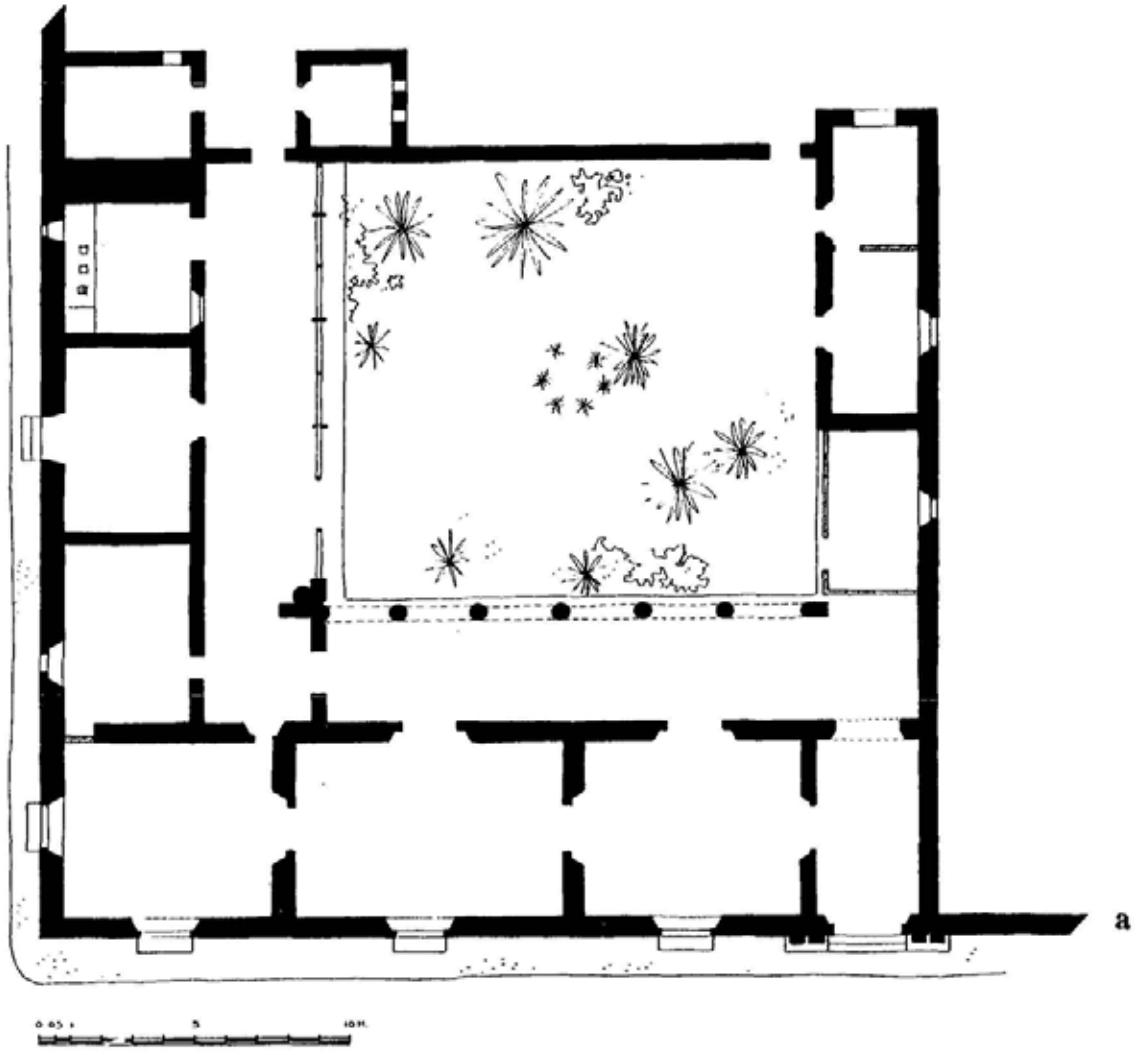
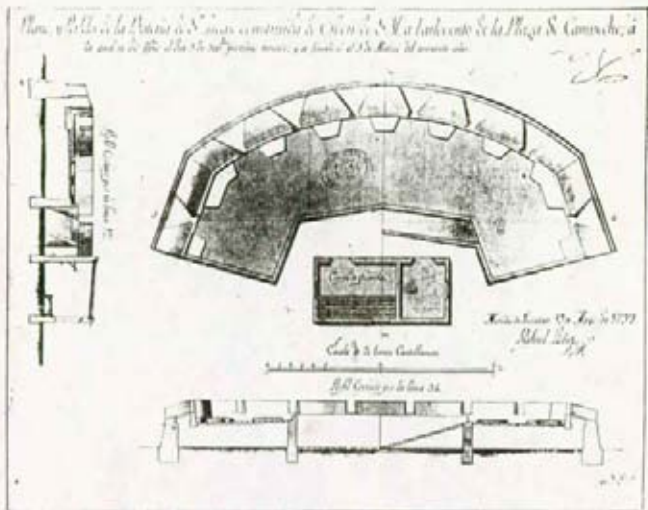

Figure 11.

Plan of Bateria de San Lucas (including guards' quarters) at Campeche, Mexico, 1792. From José Antonio Calderon Quijano *Historia de las fortificaciones en Nueva España* (Seville, 1953), fig. 114.



*Campo de guardia* = Guards' quarters

In the profile view defined by Line 1-2 (upper left), the soldiers' quarters, with sleeping platform, rack, and hanger used by the soldiers, are in the room on the right.

Figure 12. Plan of guards' quarters in Campeche, Mexico, 1802.



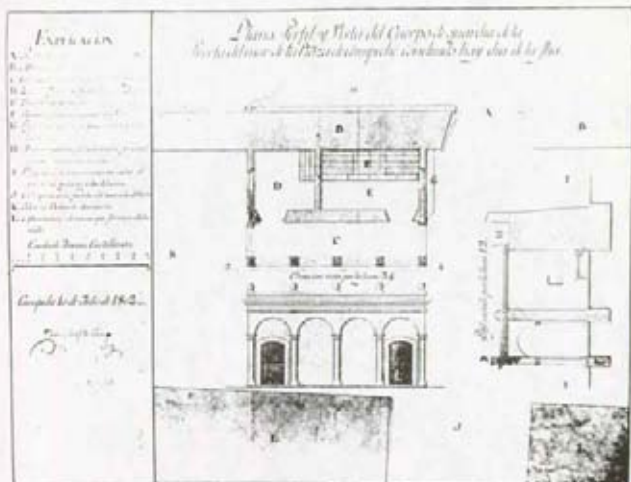

- D = Commander's room
- E = Troops' room
- F = Sleeping platform

Figure 13.

Plan and profile of guards' quarters for gunpowder warehouse for San Juan, Puerto Rico, 1769. From Altagracia Ortiz, *Eighteenth Century Reforms in the Caribbean* (East Brunswick, NJ: Associated University Press, 1983), pp. 142-143.

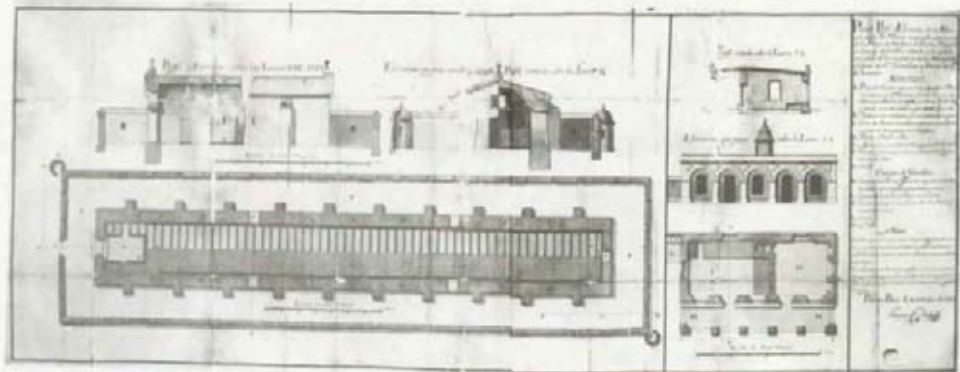

H = Commander's room

I = Soldiers' quarters with their sleeping platforms

L = Kitchen

Figure 14. Eighteenth century gunpowder storage facility in Venezuela, with attached guards' quarters. From Archivo General de Indias, AGI Mapas y Planos, Venezuela 141.

*Profillo per la Linaia et*

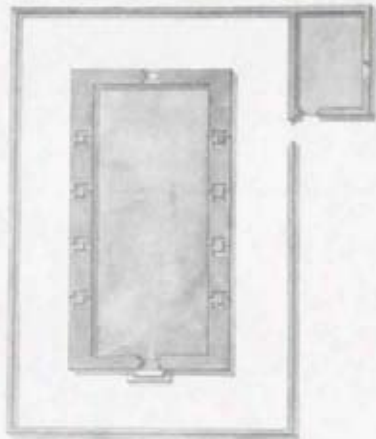

*Escudo di S. Carlo*



Figure 15.

Soldiers' rooms on second floor of Santo Domingo barracks planned in 1757. From Servicio Geográfico del Ejército, *Cartoteca historica* (Madrid, 1974), p. 104 and plan p. 27.

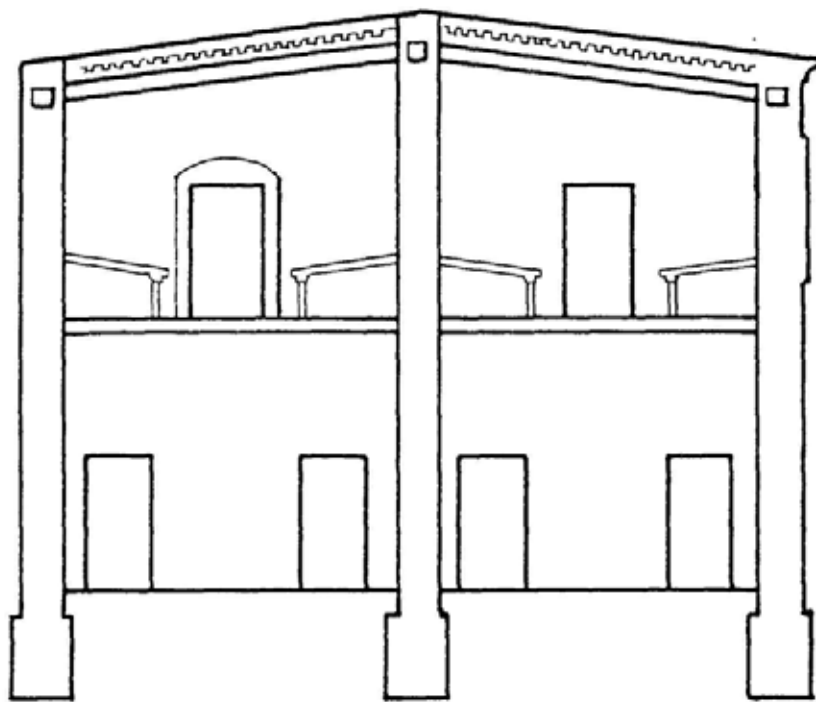

Figure 16.

Vestige of gun rack in El Morro, San Juan National Historic Site.





Figure 17.

Don Ramon Carvajal, second captain in the Fixed Regiment of Puerto Rico, in 1793. Painting by José Campeche (1751-1809). Nevans-Bolvar Family Collection, Institute of Puerto Rican Culture, San Juan.



Figure 18.

Enlargement of detail in the preceding painting (Figure 17) showing a company of the Fixed Regiment.



Figure 19.

Soldier of the Puerto Rican Fixed Regiment, 1789-1797.  
Contemporary watercolor drawing by José Campeche in the  
Uniform Section of the Archivo General de Indias, Seville,  
Spain. Courtesy of René Chartrand, Canadian Park Service.



*L'Uniforme del Reggimento Gran  
de' Arcieri di S. Pietro Russi*

Figure 20.

A contemporary drawing by José Campeche of a corporal of the Puerto Rican militia artillery, 1785. From *Spanish Military Weapons in Colonial America 1700-1821*, by Sidney B. Brinckerhoff and Pierce A. Chamberlain (Harrisburg, PA: Stackpole Books, 1972), p. 69.





Figure 21.

Puerto Rican militiaman, Infantry, 1789. Contemporary watercolor drawing by José Campeche in the Uniform Section of the Archivo General de Indias, Seville, Spain. Courtesy of René Chartrand, Canadian Park Service.



Figure 22.

Puerto Rican militiaman, Artillery, 1789. Contemporary watercolor drawing by José Campeche in the Uniform Section of the Archivo General de Indias, Seville, Spain. Courtesy of René Chartrand, Canadian Park Service.



Figure 23.

Model 1752 musket (assembled and disassembled), 1752  
carbine and pistol, with bayonet and scabbard. From  
*Spanish Military Weapons in Colonial America 1700-1821*, by  
Sidney B. Brinckerhoff and Pierce A. Chamberlain  
(Harrisburg, PA: Stackpole Books, 1972), p. 32, plate 23.

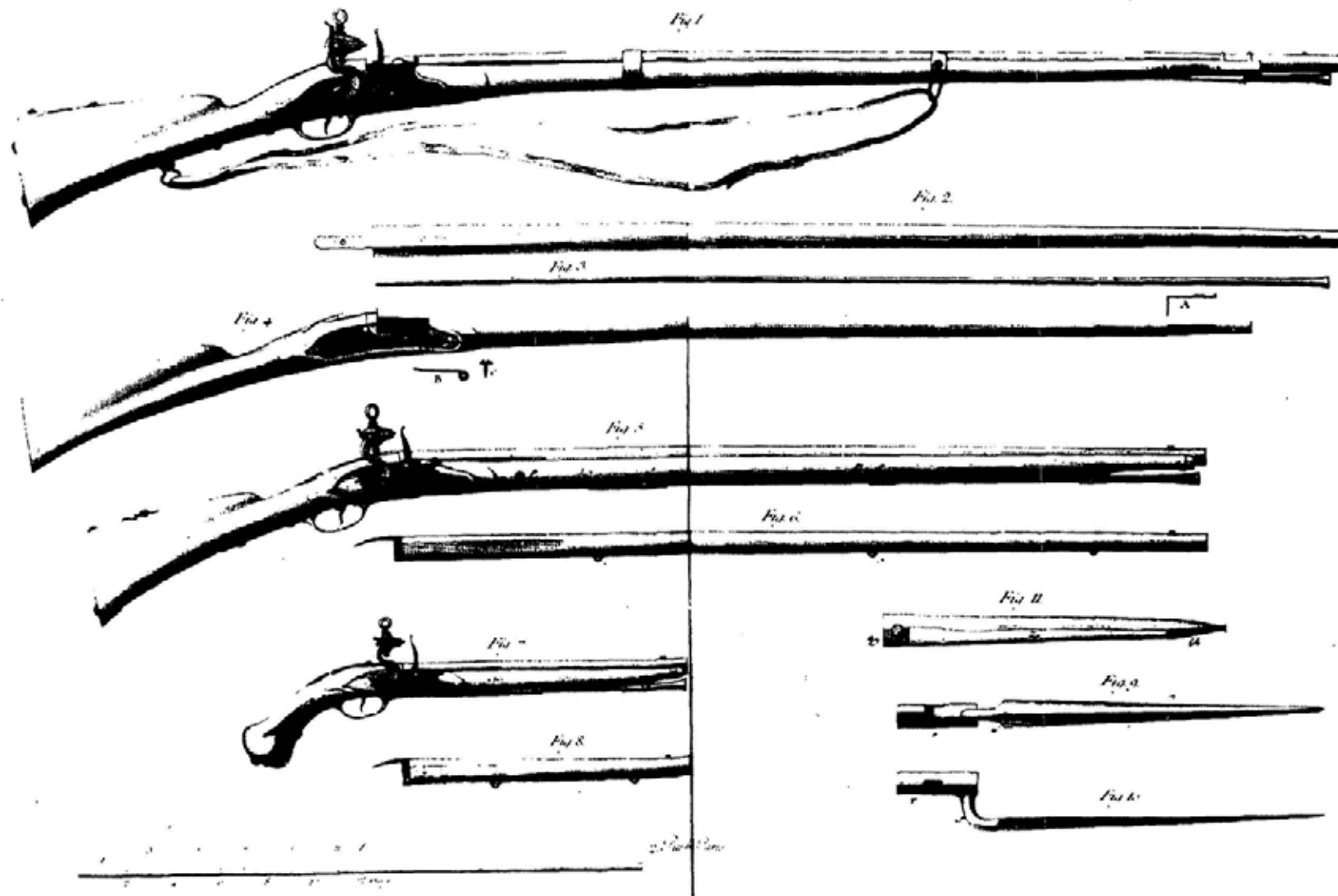

Model 1752 musket, 1752 carbine and pistol, with bayonet and scabbard.

Figure 24.

Artist's rendering, by Al Romo, of a reproduction infantry cartridge box, c. 1760. From *Spanish Military Weapons in Colonial America 1700-1821* by Sidney B. Brinckerhoff and Pierce A. Chamberlain (Harrisburg, PA: Stackpole Books, 1972), p. 70, plates 122-123.



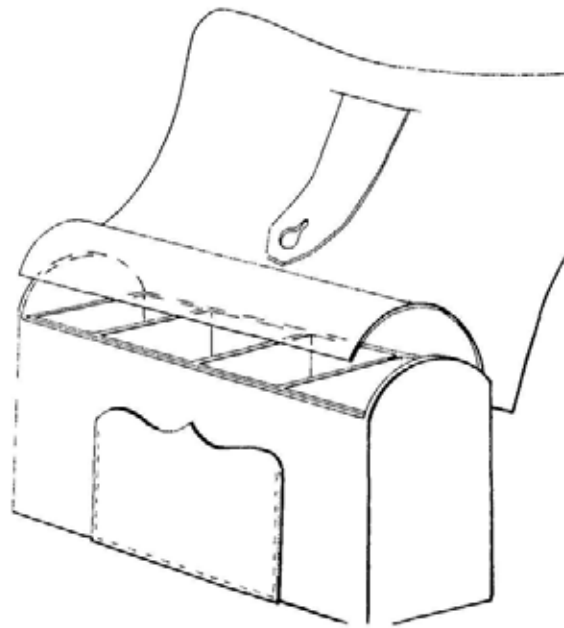
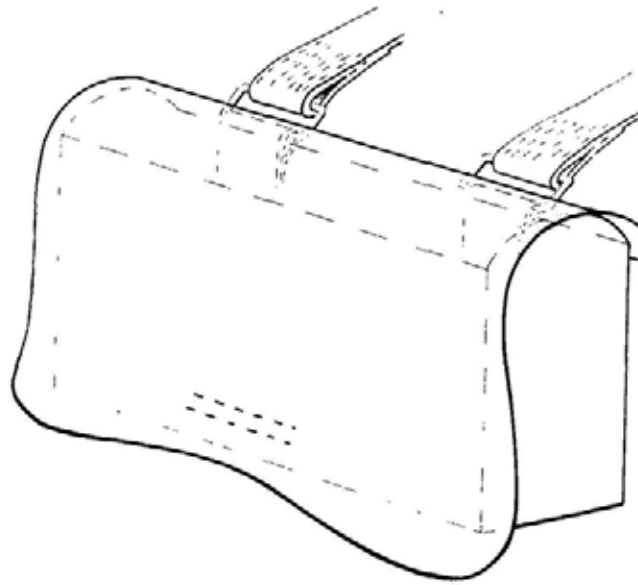

Figure 25.

Cartridge box No. 2, 1760-1770. This type of box was worn largely by foot soldiers, but also by the presidial cavalry on the northern frontier of New Spain. From *Spanish Military Weapons in Colonial America 1700-1821* by Sidney B. Brinckerhoff and Pierce A. Chamberlain (Harrisburg, PA: Stackpole Books, 1972), p. 68, plates 116-117.



Figure 26.

Sergeant's halberd, late 18th century-1814. This weapon was carried as a badge of rank by infantry sergeants throughout the 18th century and for ceremonial purposes as late as the 1860's. From *Spanish Military Weapons in Colonial America 1700-1821* by Sidney B. Brinckerhoff and Pierce A. Chamberlain (Harrisburg, PA: Stackpole Books, 1972), p. 107, plate 209.



Figure 27.

Restored 18th century French guard room at Old Fort  
Niagara, Youngstown, New York.



Figure 28.

Stools, tables, and benches. Plate no. 14 from manuscript  
no. 131D *Livre des Fortifications du Sieur Claude  
Massé...circa 1687-1728*, Bibliotheque du Genie, Service  
Historique de l'Armee de terre (Chateau de Vincennes).  
Courtesy René Chartrand, Canadian Park Service, Ottawa.



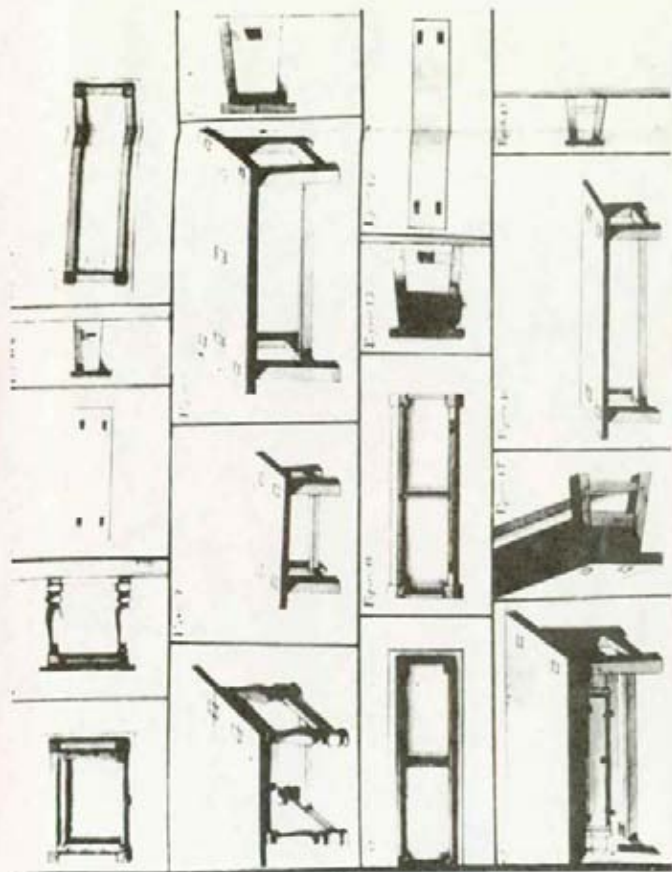

## BIBLIOGRAPHY

### BOOKS AND ARTICLES

- Abbad y Lasierra, Fray Iñigo. *Historia geográfica, civil y natural de la isla de San Juan Bautista de Puerto Rico*. Río Piedras: Ediciones de la Universidad de Puerto Rico, 1959.
- Actas del cabildo de San Juan Bautista de Puerto Rico*. San Juan: Municipio de San Juan, 1949-1978.
- Alegría, Ricardo E. *Descubrimiento, conquista y colonización de Puerto Rico, 1493-1599*. San Juan: Colección de Estudios Puertorriqueños, 1969.
- \_\_\_\_\_. *El fuerte de San Gerónimo del Boquerón*. San Juan: Instituto de Cultura Puertorriqueña, 1969.
- Almirante, José. *Diccionario militar, etimológico, histórico, tecnológico, con dos vocabularios francés y alemán*. Madrid: Imprenta y Litografía de Depósito de Guerra, 1869.
- Angulo Iñiguez, Diego. *Planos de monumentos arquitectónicos de América y Filipinas existentes en el Archivo de Indias*. 2 vols. Seville: Laboratorio del arte, 1933-1939.
- Anónimo. *Estudio histórico del cuerpo de ingenieros del ejército*. Madrid: Sucesores de Rivadeneyra, 1911.
- Arana, Luis Rafael, and Albert Manucy. *The Building of the Castillo de San Marcos*. Philadelphia: Eastern National Park & Monument Association, 1977.
- Araúz, Celestino Andrés. *El contrabando holandés en el Caribe durante la primera mitad del siglo XVIII*. Caracas: Academia Nacional de Historia, 1984.
- Archer, Christon I. *The Army in Bourbon Mexico 1760-1810*. Albuquerque: University of New Mexico Press, 1977.
- Archivo General de Indias, Sección de Mapas y Planos. *Catálogos de uniformes*. Madrid, 1981.
- Archivo General de Simancas. *Mapas, planos y dibujos de ciencia técnica en el Archivo de Simancas*. Valladolid, 1979.
- \_\_\_\_\_. *Mapas, planos y dibujos (años de 1503-1805)*. Madrid, 1980.

- Archivo General Militar, Segovia. *Catálogo de documentos, sección tercera*. Madrid: Imprenta Ideal, 1988.
- Barado, Francisco. *Museo militar. Historia del ejército español: armas, uniformes, sistemas de combate, instituciones, y organización del mismo*. 3 vols. Barcelona: Manuel Soler editor, 1884.
- Bernal Ponce, J., and G. Valparaiso Kapstein. *La arquitectura de una ciudad anfiteatro*. Santiago de Chile: Boletín de la Universidad de Chile, 1973.
- Blanco, Enrique T. *Los tres ataques británicos a la ciudad de San Juan Bautista de Puerto Rico: Drake 1595, Clifford 1598, Abercromby 1797*. San Juan: Editorial Coquí, 1968.
- Blanco, Juan. "Historic Structures Report: Fort San Cristóbal and Outworks." Columbia University: Center for Preservation Studies, June 30, 1987.
- Blanco, Tomás. *Prontuario Histórico de Puerto Rico*. San Juan: Biblioteca de Autores Puertorriqueños, 1943.
- Boxer, C. R. *The Dutch Seaborne Empire, 1600-1800*. New York: Knopf, 1965.
- Brau, Salvador. *La colonización de Puerto Rico*. San Juan: Instituto de Cultura Puertorriqueña, 1966.
- \_\_\_\_\_. *Historia de Puerto Rico*. Río Piedras: Editorial Edil, 1974.
- Brinckerhoff, Sidney B., and Pierce A. Chamberlain, *Spanish Military Weapons in Colonial America, 1700-1821* (Harrisburg, PA: Stackpole Books, 1972).
- Brown, Jonathan, and John H. Elliott. *A Palace of a King: The Buen Retiro and the Court of Philip IV*. New Haven: Yale University Press, 1980.
- Burr, Grace Hardendorff. *Hispanic Furniture From the Fifteenth through the Eighteenth Century*. New York: The Archive Press, 1964.
- Cabanillas de Rodríguez, Berta. *El Puertorriqueño y su alimentación a través de su historia (siglos XVI a XIX)*. San Juan: Instituto de Cultura Puertorriqueña, 1973.
- Cabrillana, Nicolás. "Las Fortificaciones Militares en Puerto Rico." *Revista de Indias*, vol. 27, No. 107-108 (January-July 1967), p. 157-188.

- Calderón Quijano, José Antonio. *Historia de las fortificaciones en Nueva España*. Seville: Escuela de Estudios Hispano-Americanos, 1953.
- \_\_\_\_\_. *Nueva cartografía de los puertos de Acapulco, Campeche y Veracruz*. Seville: Escuela de Estudios Hispano-Americanos, 1969.
- \_\_\_\_\_. *Bibliografía de las fortificaciones españolas en América en la Edad Moderna*. Madrid: Comisión de Estudios Históricos de Obras Públicas y Urbanismo, 1985.
- Campo Lacasa, Cristina. *Notas generales sobre la historia eclesiástica de Puerto Rico en el siglo XVIII*. Seville: Escuela de Estudios Hispano-Americanos, 1963.
- \_\_\_\_\_. *Historia de la iglesia en Puerto Rico (1511-1802)*. San Juan: Instituto de Cultura Puertorriqueña, 1977.
- Caro Costas, Aída R. *Legislación municipal puertorriqueña del siglo XVIII*. San Juan: Instituto de Cultura Puertorriqueña, 1971.
- Castillero, Ernesto. J. *Grandeza y decadencia del castillo de San Lorenzo de Chagres*. Panama: E. J. Castillero, 1954.
- Castro, María de los Angeles. *Arquitectura en San Juan de Puerto Rico (siglo XIX)*. Río Piedras: Universidad de Puerto Rico, 1980.
- Céspedes del Castillo, Guillermo. "La Defensa del Istmo de Panama a Finales del siglo XVII y Principios del XVIII." *Anuario de Estudios Americanos*, XIX, 1962.
- Chardón, Carlos Fernando. *Reseña histórica del origen y desarrollo de las milicias puertorriqueñas bajo el régimen español 1598-1898*. San Juan: Impresora, Ramallo, 1978.
- Clonard, Conde del. *Historia orgánica de las armas de caballería e infantería*. 16 vols. Madrid: Imprenta de D. B. González, and Imprenta Boletín de Jurisprudencia, 185?
- Colamar Albajar, María Antonia. *Catálogo de uniformes, sección de mapas y planos, Archivo General de Indias*. Madrid: Ministerio de Cultura, 1981.
- Colección general de máquinas escogidas*. 2 vols. Madrid: Andrés Ramírez, 1773-1784.
- Coll y Toste, Cayetano. Ed. *Boletín Histórico de Puerto Rico (1914-1927)*. 14 vols. Barcelona: Jorge Casas Monserrat, 1971.

- Comisión de Estudios Históricos de Obras Públicas y Urbanismo; actas del seminario. *Puertos y fortificaciones en América y Filipinas*. Madrid: CEHOPU, 1985.
- Comisión Redactora, *Estudio histórico del cuerpo de ingenieros*. Madrid, 1902.
- Córdoba, Pedro Tomás de. *Memorias geográficas, históricas, económicas y estadísticas de la Isla de Puerto Rico*. 6 vols. San Juan: Instituto de Cultura Puertorriqueña, 1968.
- Cruz Monclova, Lidio. *Historia de Puerto Rico, siglo XIX*. Río Piedras: Editorial Universitaria, 1952.
- Danvilla y Collado, Manuel. *Trajes y armas de los españoles desde los tiempos prehistóricos hasta los primeros años del siglo XIX*. Madrid: Imprenta de T. Fontanet, 1877.
- Delgado, Jaime. "Desarrollo Independencia siglos XVII, XVIII y XIX." *Gran enciclopedia de España y América*, 1984, vol. V, p. 231.
- Delgado Mercado, O. *Conservación de San Juan Antiguo*. San Juan: Instituto de Cultura Puertorriqueña, 1956.
- Department of Military Affairs, Florida National Guard. *The Military and Militia in Colonial Spanish America*. St. Augustine, FL: unpublished mimeograph, 1985.
- Diderot, Denis. *Diderot Encyclopedia - The Complete Illustrations, 1762-1777*, 5 vols. New York: Henry N. Abrams, Inc., 1978.
- Doménech, Rafael, and Luis Pérez Bueno. *Antique Spanish Furniture-Muebles antiguos españoles*. New York: The Archive Press, 1965.
- Domínguez Ortiz, Antonio. *Sociedad y estado en el siglo XVIII español*. Barcelona: Ariel S.A., 1976.
- Eberlein, Harold Donaldson. *Spanish Interiors, Furniture, and Details From the 14th to the 17th Century*. New York: Architectural Book Publishing Co., 1925.
- Emerson, Ann P. "Standards of Nutrition in a St. Augustine Hospital, 1783-1821," in *Florida Historical Quarterly*, 65:2 (October 1986), 145-162.
- Espinosa, Manuel de. "Libros de ordenanzas de los pífanos y tambores." España, manuscript, 1761.
- Feduchi, L. *El mueble español*. Barcelona, Ediciones Polígrafa, S. A., 1969.

- Feduchi, Luis M. *Spanish Furniture*. New York: Tudor, 1969.
- Fernández Duro, Cesáreo. *Armada española desde la unión de los reinos de Castilla y Aragón*, 9 vols. Madrid, Sucesores de Rivadeneyra, 1895-1903.
- Fernández Méndez, Eugenio. *Historia cultural de Puerto Rico, 1493-1968*. San Juan: Ediciones El Cemí, 1970.
- . *Crónicas de Puerto Rico, desde la conquista hasta nuestros días (1493-1955)*. San Juan: Editorial Universidad de Puerto Rico, 1976.
- Ferrer, Don José. *Album del ejército*. 3 vols. Madrid: Hortelano y Cia., 1846.
- Figueroa, Loida. *Breve historia de Puerto Rico; desde sus comienzos hasta 1892*. Río Piedras: Editorial Edil, 1971.
- Fonfrias, Ernesto Juan. *Puerto Rico en la defensa del imperio español en América; ensayo breve*. San Juan: 1968.
- Gasparini, Graziano. *La arquitectura colonial de Coro*. Caracas: Ediciones A, 1961.
- . *La casa colonial venezolana*. Caracas: Universidad Central de Venezuela, 1962.
- . *Las fortificaciones del período hispano en Venezuela*. Caracas: Ernesto Armitano Editor, 1985.
- Gillespie, Charles Coulston, ed. *A Diderot Pictorial Encyclopedia of Trades and Industry*, 2 vols. New York: Dover Publications, 1959.
- La gran enciclopedia de Puerto Rico*. 15 vols. Madrid: C. Corredera, 1976-1980.
- Haring, C. H. *The Spanish Empire in America*. New York: Harcourt, Brace, Jovanovich, 1975.
- Heredia Herrera, Antonia. "Las Fortificaciones en la Isla Margarita en los siglos XVI, XVII y XVIII." *Anuario de Estudios Americanos*, XV, (Seville, 1958).
- Hostos, Adolfo. *Ciudad murada. Ensayo acerca del proceso de la civilización en la ciudad española de San Juan de Puerto Rico, 1521-1898*. La Habana: Editorial Lex, 1948.
- . *Crecimiento y desarrollo de la ciudad de San Juan*. San Juan: Instituto de Cultura Puertorriqueña, 1957.

- Hostos, Adolfo de. *Historia de San Juan: ciudad murada 1521-1898*. San Juan: Instituto De Cultura Puertorriqueña, 1966.
- Hoyt, Edward A. *A History of the Harbor Defenses of San Juan, P.R., under Spain, 1509-1898*. San Juan: Puerto Rico Coast Artillery Command, 1943.
- Kubler, George, and Martin Soria. *Art and Architecture in Spain and Portugal and their American Dominions*. Baltimore: Penguin Books, 1959.
- Ledru, André Pierre. *Viaje a la isla de Puerto Rico en el año de 1797*. Río Piedras: Universidad de Puerto Rico, 1957.
- León Tello, Pilar. *Mapas, planos y dibujos de la Sección del Estado del Archivo Histórico Nacional*. Madrid, 1969.
- Lohman Villena, Guillermo. *Las defensas militares de Lima y Callao hasta 1746*. Seville: Escuela de Estudios Hispano-Americanos, 1964.
- López Cantos, Angel. *Historia de Puerto Rico, 1650-1700*. Seville: Escuela de Estudios Hispano-Americanos, 1975.
- Manucy, Albert. *The Houses of St. Augustine*. St. Augustine: St. Augustine History Society, 1962.
- \_\_\_\_\_, and Ricardo Torres-Reyes. *Puerto Rico and the Forts of Old San Juan*. Old Greenwich, CT: Chatham Press, 1973.
- Marchena Fernández, Juan. *La institución militar en Cartagena de Indias 1700-1810*. Seville: Escuela de Estudios Hispano-Americanos de Seville, 1982.
- \_\_\_\_\_. *Oficiales y soldados en el ejército de América*. Seville: Escuela de Estudios Hispano-Americanos, 1983.
- \_\_\_\_\_. "Gobierno y Población Militar en Florida Oriental 1700-1820," unpublished typescript. Gainesville, FL: P.K. Yonge Library, 198?
- Marco Dorta, Enrique. *Cartagena de Indias; puerto y plaza fuerte*. Cartagena: A. Amando, 1960.
- Margon, Lester. *Masterpieces of European Furniture 1300-1840*. New York: Architectural Book Publishing Co., 1968.
- Miller, Judith and Martin, eds. *The Antique Directory. Furniture*. Boston: G.K. Hall and Co., 1985.

- Mirayes González, Fernando. *Noticias particulares de la isla y plaza de San Juan Bautista de Puerto Rico*. Río Piedras: Universidad de Puerto Rico, 1954.
- Moorehead, Max L. *The Presidio: Bastion of the Spanish Borderlands*. Norman: University of Oklahoma Press, 1975.
- Museo de las Casas Reales, Santo Domingo. *Sala de armas: catálogo*. Santo Domingo, 1983.
- Ordenanzas del ejército para su régimen, disciplina, subordinación y servicio. Dadas por S. M. Católica en 22 de octubre de 1768*. Caracas: Imprenta de V. de Espinal, 1841.
- Ordenanza dividida en catorce reglamentos que Su Magestad manda observar en el Real Cuerpo de Artillería para sus diferentes ramos de tropa, cuenta y razón, y fábricas*. 2 vols. Madrid: Imprenta Real, 1802.
- Ordenanzas generales de la armada naval*. 2 vols. Madrid: Imprenta de la viuda de Don Juan de Ibarra, 1793.
- Ordenanza militar para el régimen, disciplina, subordinación y servicio del ejército*. 2 vols. Mexico: Imprenta de José M. Lara, 1842.
- Ortiz, Altagracia. *Eighteenth Century Reforms in the Caribbean; Miguel de Muesas, Governor of Puerto Rico 1769-76*. East Brunswick, NJ: Associated University Presses, Ltd, 1983.
- Peña Marazuela, María Teresa de la. *Archivo Histórico Nacional, Sección de Ultramar*. 6 vols. Madrid: Servicio de Publicaciones del Ministerio de Educación y Ciencias, 1972-1975.
- Perea, Salvador. *Historia de Puerto Rico, 1537-1700*. San Juan: Instituto de Cultura Puertorriqueña, 1972.
- Pike, Ruth. *Penal Servitude in Early Modern Spain*. Madison, WI: The University of Wisconsin Press, 1983.
- Real Academia de la Historia. *Colección de documentos, opúsculos, y antigüedades que publica la Real Academia de la Historia*. 46 vols. Madrid: 1851-1915.
- Real Díaz, José Joaquín. *Catálogo de las cartas y peticiones del cabildo de San Juan Bautista de Puerto Rico en el Archivo General de Indias, siglos XVI a XVIII*. San Juan: Instituto de Cultura Puertorriqueña, 1968.



- Reglamento para la guarnición de la plaza de Puerto Rico, castillos, y fuertes de su jurisdicción.* Madrid: Oficina de los herederos de Juan de Arista, 1741. Note: this document is also found in Archivo General de Indias, Santo Domingo 2499.
- Reglamentos primero y segundo del real cuerpo de artillería.* Madrid: Imprenta Real, 1808.
- Rivera Ayala, Noel. "Las Milicias Disciplinadas Puertorriqueñas: grandes períodos y el duradero valor de la institución (1765-1800," unpublished M.S. thesis, Universidad de Puerto Rico, Río Piedras (1978).
- Rodríguez Villafaña, Leonardo. *Catálogo de mapas y planos de Puerto Rico en el Archivo General de Indias.* San Juan: Publicaciones del Municipio de San Juan, 1966.
- Rodríguez Morales, Luis M. *La vida de la ciudad de San Juan Bautista a mediados del siglo XVIII vista a través de sus actas capitulares.* San Juan: Instituto de Cultura Puertorriqueña, 1957.
- Rodríguez del Valle, Mariana. "El castillo de San Felipe del Golfo Dulce; historia de las fortificaciones de Guatemala en la Edad Moderna." *Anuario de Estudios Americanos*, XVII, Seville, 1960.
- Rodríguez Casado, Vicente, and Floentino Pérez Embid. *Construcciones militares del Virrey Amat.* Seville: Escuela de Estudios Hispano-Americanos, 1949.
- Roig de Leuchsensing, E. *Fortalezas coloniales de la Habana.* La Habana: Junta Nacional de Arqueología, 1960.
- Sanz Pastor, Consuelo. *Museo de las Casas Reales, Santo Domingo, República Dominicana.* Barcelona: Sirvensae, 1976.
- Segovia Salas, Rodolfo. *The Fortifications of Cartagena de Indias.* Bogotá: Carlos Valencia Editores, 1982.
- Servicio Geográfico del Ejército. *Cartoteca histórica.* Madrid: Imprenta del Servicio Geográfico del Ejército, 1974.
- Servicio Histórico Militar. *Catálogo general de la cartoteca.* 2 vols. Madrid: Imprenta Ideal, 1985.
- Smith, George. *A Universal Military Dictionary or a Copious Explanation of the Technical Terms &c Used in the Equipment, Machinery, Movements, and Military Operations of an Army.* Ottawa: Museum Restoration Service, 1969 (reprint of London, 1779 edition).

- Tapia y Rivera, Alejandro, ed. *Biblioteca histórica de Puerto Rico*. San Juan: Instituto de Cultura Puertorriqueña, 1970.
- Taylor, Lon, and Dessa Bodikes. *New Mexico Furniture, 1600-1940: The Origins, Survival, and Revival of Furniture Making in the Hispanic South West*. Santa Fe, NM: Museum of New Mexico Press, 1987.
- Taylor, René. *José Campeche y su tiempo*. San Juan: Graf Inc., 1987?
- Tiό, Aurelio. *Nuevas fuentes para la historia de Puerto Rico*. San Germán: Universidad Interamericana, 1966.
- Torres Ramírez, Bibiano. *La isla de Puerto Rico (1765-1800)*. San Juan: Instituto de Cultura Puertorriqueña, 1968.
- \_\_\_\_\_. *Alejandro O'Reilly en las Indias*. Seville: Escuela de Estudios Hispano-Americanos, 1969.
- Torres-Reyes, Ricardo, and Albert Manucy. *Puerto Rico and the Forts of San Juan*. Greenwich, CT: Chatham Press, 1973.
- Torres Vargas, Diego. "Descripción de la Isla de Puerto Rico y de su Vecindad y Poblaciones, Presidio, Gobernadores y Obispos: Frutos y Minerales," 1647, in Alejandro Tapia y Rivera, *Biblioteca histórica de Puerto Rico*. San Juan: Imprenta de Marquéz, 1854, pp. 447-496.
- Vallecillo, Antonio. *Ordenanzas de Su Magestad para el régimen, disciplina, subordinación, y servicio de sus ejércitos*. 3 vols. Madrid: Imprenta de los señores Andrés y Díaz, 1851.
- Vedder, Alan C. *Furniture of Spanish New Mexico*. Santa Fe, NM: Sunstone Press, 1982.
- Velázquez, María del Carmen. *El estado de guerra en nueva España 1760-1808*. Mexico: Colegio de Mexico, 1950.
- Vidal, Teodoro. *La fortaleza. San Juan de Puerto Rico*. San Juan, 1964.
- Vila Vilar, Enriqueta. *Historia de Puerto Rico 1600-1650*. Seville: Consejo Superior de Investigaciones, 1974.
- Weiss, Joaquín. *La Arquitectura colonial cubana*. 2 vols. La Habana: Editorial Letras Cubanas, 1979.
- Wright, Irene. *Historia documentada de San Cristóbal de la Habana en el siglo XVI*. La Habana: Imprenta el siglo XX, 1927.

Zapatero, Juan Manuel. "La Escuela de Fortificación Hispanoamericana".  
*Revista de historia militar*, 25, (1959), pp. 27-47.

\_\_\_\_\_. *El período de esplendor de las fortificaciones de San Juan de Puerto Rico*. Madrid: Publicaciones Asinto, 1959.

\_\_\_\_\_. *La guerra del Caribe en el siglo XVIII*. San Juan: Instituto de Cultura Puertorriqueña, 1964.

\_\_\_\_\_. *Historia de las fortificaciones de Puerto Cabello*. Caracas: Banco Central de Venezuela, 1977.

\_\_\_\_\_. *Historia de las fortalezas de Santa Marta y estudio asesor para su restauración*. Bogotá: Academia Colombiana de Historia, 1980.

\_\_\_\_\_. *Historia del castillo de San Lorenzo del Real de Chagres*. Madrid: Comisión de Estudios Históricos de Obras Públicas y Urbanismo, 1985.

Zeno, F. M. *Historia de la capital de Puerto Rico*. 2 vols. San Juan: Publicación oficial del gobierno de la capital, 1959.

Zúñiga, Juan de. *Ordenanzas de Su Magestad para el gobierno militar, político y económico de su armada real*. 2 vols. Madrid: 1748.

## GOVERNMENT PUBLICATIONS

National Park Service, U.S. Department of the Interior. *La Plaza de Puerto Rico; 1765-1777*. Prepare by Ricardo Torres-Reyes. Manuscript. San Juan: NPS, 1952.

\_\_\_\_\_. *Historic Structure Report. Part I, Historical Data Section. Officers' Quarters, Fort San Cristóbal, San Juan National Historic Site*. Prepared by Ricardo Torres-Reyes. San Juan: NPS, 1961.

\_\_\_\_\_. *Historic Structure Report. Part I, Officers' Quarters, Castillo de San Cristóbal*. Prepared by Woodrow W. Wilkins. San Juan: NPS, 1961.

\_\_\_\_\_. *Historic Structure Report. Part II, Officers' Quarters, Architectural Data Section, Fort San Cristóbal, San Juan National Historic Site*. Prepared by Russell V. Keune. San Juan: NPS, 1962.

\_\_\_\_\_. *Castillo de San Cristóbal: North Casemates, San Juan, Puerto Rico, Historic American Building Survey*, NPS, 1963.

- \_\_\_\_\_. *Historic Structure Report. Part 2 (Supplement), Officers' Quarters: Architectural Data Section, Castillo de San Cristóbal, San Juan National Historic Site.* Prepared by Frederic C. Gjessing, Eastern Office of Design and Construction. San Juan: NPS, 1964.
- \_\_\_\_\_. *Historic Structure Report. San Cristóbal Gates (RSP-H-2).* Prepared by Ricardo Torres-Reyes. San Juan: NPS, 1964.
- \_\_\_\_\_. *Construction History of San Cristóbal: 1634-1800.* Prepared by Ricardo Torres-Reyes. San Juan: NPS, 1965.
- \_\_\_\_\_. *Historic Structure Report. Part I, Historical Data Section, San Juan Fortifications, 1898-1958.* Prepared by Edwin C. Bearss. San Juan: NPS, 1979.
- \_\_\_\_\_. *Historic Structure Report. The Fortifications of San Juan National Historic Site., Vols 1-4 (particularly vol. 2, El Fuerte de San Cristóbal).* Prepared by Joan Berkowitz, *et al*, Building Conservation Branch, Cultural Resources Center, North Atlantic Region, National Park Service; and Center for Preservation Research, Columbia University, 1991.

## DOCUMENTS

### A. From Archivo General de Indias, Seville, Spain (AGI)

AGI Escribanía de Cámara 123A

Sermon on Archangel St. Michael, 1656

AGI Escribanía de Cámara 123B

Information on services José de Novoa y Moscoso, 1660

AGI Escribanía de Cámara 124A

Various documents, 1647

AGI Escribanía de Cámara 133C

No. 5: Information on English attack on San Juan, 1598

AGI Escribanía de Cámara 134A

San Juan is taken by the English

AGI Escribanía de Cámara 134B

Information on English attack on San Juan, 1598

AGI Indiferente General 1887.

Artillery required for San Juan, 1581

Other provisions required for San Juan, 1583, 1586, 1587,  
Caribbean defenses, 1588  
Requirements Puerto Rico [hereafter cited as P.R.] 1598  
Provisions sent to Puerto Rico [hereafter cited as P.R.] 1629-1633  
Visit Engineer Juan B. Antonelli, 1630  
Information on corsairs, 1643

AGI Patronato 50

No. 23, ramo 5: Information on Antonio Enríquez de Castellanos, 1560  
No. 24, ramo 5: P. R. needs stipulated by Enríquez, 1560

AGI Patronato 51

No. 24, 2, ramo 5: Information on Francisco Juancho. San Juan's city council  
request to King, 1546  
No. 25, 2, ramo 3: Information on Melchor Troche

AGI Patronato 175

Ramo 8: Information on Diego de Figueroa  
Ramo 20: Trinidad grant to Antonio Sedeño  
Ramo 27: fortress of San Juan, 1550  
Ramo 28: Combat readiness San Juan, 1541  
Ramo 30: safeguard of P. R. 1549  
Ramo 38: mention fortress San Juan, 1582  
Ramo 39: Visit Pedro Suárez Coronel to El Morro  
Ramo 42: Puerto Rico's troops, 1599

AGI Patronato 176

Ramo 3: Description island and port, P. R. 159-?  
Ramo 10: Mention Ponce de León to Florida, 1521  
Ramo 20: Information Pedro de Salazar, 1591

AGI Santo Domingo, Mapas y Planos.

No. 35: Description Punta de Adentro, 1630  
No. 36: Description La Puntilla fort, 1630

AGI Santo Domingo 155.

No. 2: forts P. R. 1605  
No. 5: Juan Bautista Antonelli and Juan de Tejada, 1591  
No. 7: defenses of the island, 1576  
No. 8: state of P. R. 1567  
No. 9: state of P. R. 1550  
No. 10: Puerto Rican officials to King  
No. 11: information by Diego Méndez de Sotomayor  
No. 12: arrival of galleons, 1606  
No. 13: corsairs in Puerto Rico's vicinity, 1571, 1583.  
No. 16: information on Juan de Tejada, 1594

AGI Santo Domingo 156

- No. 3: state of P. R. 1608, 1612
- No. 19: location of arms, 1613
- No. 21: report by Governor Juan de Haro, 1626.  
Other documents 1637, 1650
- No. 22: report by Governor Iñigo de la Mota, 1638, 1641
- No. 23: report by Governor Riba Aguero, 1646
- No. 24: report by Riba Aguero, 1643, 1646
- No. 25: other reports, 1634, 1641

AGI Santo Domingo 157

- No. 26: documents on P. R. dated 1656, 1658, 1664
- No. 27: report 1662
- No. 28: other documents 1671
- No. 29: documents 1661, 1664, 1671
- No. 30: construction hospital, 1674
- No. 31: other documents 1675
- No. 32: other documents 1675

AGI Santo Domingo 158

- State of P. R. 1638
- No. 33: other documents 1674, 1678
- No. 34: other documents 1677
- No. 35: other documents 1680
- No. 36: other documents 1678, 1680, 1681
- No. 37: other documents 1681
- No. 38: other documents 1682

AGI Santo Domingo 159

- No. 39: documents on P. R. 1686
- No. 40: other documents 1685
- No. 41: information by Jacinto Lope, 1688
- No. 43: Baltasar de Andino's belongings are impounded
- No. 44: more on Andino
- No. 45: more on Andino
- No. 46: more on Andino, 1688
- No. 47: other documents 1684
- No. 48: other information 1688
- No. 49: other information 1687
- No. 51: report by Governor Gaspar de Arredondo, 1691
- No. 52: report by Governor Arredondo, 1690
- No. 53: other documents 1691
- No. 54: English sloop with Spanish prisoners

AGI Santo Domingo 160

- No. 55: Florida Indians detained by English, 1691
- No. 56: Florida Indians contribute salvaging shipwreck

No. 57: more on shipwreck  
No. 58: more on shipwreck  
No. 59: report Governor Arredondo, 1693  
No. 60: report Arredondo, 1694  
No. 61: report Arredondo, 1692

AGI Santo Domingo 161

No. 62: report Arredondo, 1692  
No. 63: needs on P. R. 1694

AGI Santo Domingo 162

No. 64: other documents 1692  
No. 65: French corsairs in the vicinity of P. R.  
No. 66: report Arredondo, 1697  
No. 67: cathedral accounts

AGI Santo Domingo 163

No. 68: letter Antonio de Robles, 1699  
No. 69: report by Antonio de Silva, 1699  
No. 70: other documents 1699

AGI Santo Domingo 164

Nos. 77, 78, 80, 101: State of P. R. 1566

AGI Santo Domingo 165

No. 81: requirements fortress P. R. 1587  
No. 82: the King acknowledges services city San Germán, 1626  
No. 83: more on services San Germán  
No. 84: report Gregorio Sanmillán on the island  
No. 85: continuation report Sanmillán

AGI Santo Domingo 167

Various documents, 1660, 1664

AGI Santo Domingo 171.

Other documents, 1636-1646

AGI Santo Domingo 535A

No. 86: state of the island in 1657  
No. 87: report on the island by Governor Pérez de Guzmán  
No. 88: correspondence Governor Haro, 1630  
No. 89: correspondence Governor Ochoa de Castro  
No. 90: correspondence de la Mota Sarmiento, 1630

AGI Santo Domingo 535B

No. 91: government matters, 1695  
No. 92: government matters, 1695-1700

No. 93: repairs to the cathedral  
No. 94: English sloop detained in San Juan  
No. 95: more on English sloop  
No. 96: more English ships in the vicinity of San Juan  
No. 97: two French sloops are detained

AGI Santo Domingo 536

No. 98: correspondence Governors, 1628, 1687  
No. 99: correspondence Governor, 1690  
No. 100: correspondence Governor, 1696

AGI Santo Domingo 546

Families arriving from Canary Islands, 1727

AGI Santo Domingo 547

Report on hurricane damage, 1738

AGI Santo Domingo 548

Report on Vieques Island, 1753

AGI Santo Domingo 549

Development plan 1757  
Commerce with Denmark

AGI Santo Domingo 560

Various documents 1703

AGI Santo Domingo 561

Report on defenses P. R. 1702-1703

AGI Santo Domingo 2283

James O'Daly to be accepted in P. R.  
Development of agriculture, 1775

AGI Santo Domingo 2286

Complete inventory cathedral San Juan  
Plan to populate Cangrejos Island

AGI Santo Domingo 2287

Fernando VII's government rules, 1813

AGI Santo Domingo 2288

State of agriculture 1798  
Bishop steals construction materials from the forts  
Censuses 1789, '90, '92, '94, '95, '97, '99, 1800, '01, '02, '07



AGI Santo Domingo 2289

Armed forces 1687  
Carmelitas' Convent 1735

AGI Santo Domingo 2296

Governor's correspondence, 1713

AGI Santo Domingo 2297

Canary Islands's families to P. R. 1722  
Governor's report, 1722

AGI Santo Domingo 2298

List of services rendered by Governor Antonio de Mendizábal  
Report Governor Matías de Abadía  
Names and salaries military personnel active in P. R. 1736

AGI Santo Domingo 2299

Governor renders the King complete report on P. R. 1758  
List of services Governor Ramírez de Estenor

AGI Santo Domingo 2300

Inventory arms and ammunition, 1766  
Description military personnel active, 1766  
Alexander O'Reilly's military regulations

AGI Santo Domingo 2301

Inventory arms and ammunition, 1777  
Forts' construction report, January 1777  
Forts' construction report, June 1777  
Officers' service records to 1777  
Inventory arms and ammunition, 1776

AGI Santo Domingo 2302

Censuses Puerto Rico 1779, 1782, 1783, 1784  
Inventory arms and ammunition, 1778

AGI Santo Domingo 2303

Inventory arms and ammunition, 1783  
List all salaried military and civilian personnel, 1783

AGI Santo Domingo 2304

Inventory arms and ammunition, 1784  
Description military uniforms, 1784  
Militia officers in each town  
Officers' service records, 1784

AGI Santo Domingo 2305

Tobacco produced by Puerto Rican provinces  
Militia officers, 1785

AGI Santo Domingo 2306

Inventory arms and ammunition, 1786  
Troops' and militia's report, 1786  
Treasury report, 1786

AGI Santo Domingo 2308

Expenses report on defense constructions 1788  
Inventory arms and ammunition, 1788  
Regular army officers, 1787  
Militia officers, 1788

AGI Santo Domingo 2309

Service records Governor Daban, 1788  
Description militias, 1789  
Militias' inspection, 1789  
Officers' service records, 1789  
Commerce San Juan-Amsterdam  
Censuses 1788, 1789, 1790, 1792, 1793

AGI Santo Domingo 2310

Importation of slaves, 1791  
Relacion de las embarcaciones que entraron en 1790 al puerto de San Juan,  
1790

AGI Santo Domingo 2311

Marquis de Sonora and trade with Holland

AGI Santo Domingo 2312

Situado, 1793  
List of medicines needed by Royal Hospital  
Contraband, 1793

AGI Santo Domingo 2313

Officers' service records, 1794

AGI Santo Domingo 2314

Detailed description all registered ships, 1795  
Treasurer's report, 1795

AGI Santo Domingo 2317

Arrival seven runaway slaves from St. Eustatius

AGI Santo Domingo 2318

Hurricanes, 1798

Census, 1798

Slaves' imports, 1798

Military personnel ready to be promoted

Santo Domingo 2319

Hurricanes and rains

AGI Santo Domingo 2360

Censuses 1777, 1778

AGI Santo Domingo 2361

Establishment towns Añasco and Yauco

Establishment seven towns, 1775

AGI Santo Domingo 2366

Information on James O'Daly, brother of Engineer Thomas

Administration local income, 1787

AGI Santo Domingo 2395

O'Reilly is commissioned to visit P. R.

AGI Santo Domingo 2396

Various land distributions, 1774-1790

Report on the island by Governor Ustariz, 1789

AGI Santo Domingo 2489A

Contracts with Holland to create local tobacco plantations

Tobacco commerce with Caracas

AGI Santo Domingo 2491

Flour prices 1794

AGI Santo Domingo 2492

Supplement to *Gaceta de Puerto Rico*, Aug. 17, 1808

Port improvement plan, 1806

AGI Santo Domingo 2496

Money and provisions to be sent from Mexico; 1634-1687

AGI Santo Domingo 2499

No. 1: Report Engineer Fernández de Valdelomar, 1731

No. 2: Puerto Rican defenses, 1731

No. 3: soldiers and ammunition required for San Juan, 1731

No. 4: on defenses San Juan, 1733, 1734, 1737, 1739

No. 5: correspondence Governor, 1739, 1740

No. 6: correspondence Governor, 1741  
No. 7: correspondence Governor, 1741  
No. 8: requirements for defenses P. R. 1741  
No. 10: defense budget 1741  
No. 11: military rules, 1741  
No. 12: continuation of military rules, 1741  
No. 13: continuation of military rules, 1741  
No. 14: costs implementing new military rules  
No. 15: correspondence Governor Abadía, 1741  
No. 16: troops' review, 1743  
No. 17: troops' review, 1749

AGI Santo Domingo 2500

Inventory arms and ammunition, 1760  
Troops' review, 1760  
Governors' reports 1735-1760 on defense requirements  
Officers' records to 1761  
Uniforms required for 400 army men  
Inventory arms and ammunition, 1755

AGI Santo Domingo 2501

Report on P. R. and its defenses, 1760-1764  
O'Reilly's trip to P. R. 1764  
O'Daly reports on arrival O'Reilly, 1765  
Shipments to P. R. 1765  
O'Reilly report on Puerto Rico's needs, 1765  
San Juan defenses report, 1765

AGI Santo Domingo 2502

Troops' review, 1766  
Guns and ammunition on hand, 1767  
Items sent from Spain to P. R., 1767-68  
No. 26: troops' review, 1768  
No. 27: complete inventory all royal items, 1768  
No. 28: loss of soldiers working in fort construction  
No. 29: officers' service records, troops' review, 1766  
No. 30: guns and ammunition inventory, 1770  
No. 31: provisioning of limestone and bricks for fort construction

AGI Santo Domingo 2503

O'Daly's report on fort construction, January, 1769  
Fort construction report, June, 1769  
Fort construction report, October 1769  
Fort construction report March 1770  
Description San Cristóbal plan, 1769  
Inventory articles in warehouse, 1769  
Inventory arms and ammunition, 1769

Troops' review, 1769  
Personnel working in construction, 1769  
Construction gunpowder warehouse, 1770  
Limestone for construction, 1770  
Inventory arms and ammunition, 1770

AGI Santo Domingo 2504

Report on the fall of a San Cristóbal wall, 1769  
Planned forts for San Juan, November 1769  
Forced labor working on forts, 1769  
Fort plans, 1771  
Budget for fixing the streets of San Juan, 1772  
Shipment arms to San Juan  
Fort construction report, May 1773  
Fort construction report, January 1774  
Fort construction report, June 1774  
Fort construction report, January 1775  
Fort construction report, May 1775  
Fort construction report, September 1775  
Fort construction report, October 1776  
Fort construction report, January 1777  
Fort construction report, June 1777  
Fort construction report, October 1777  
Fort construction report, January 1778  
Fort construction report, June 1779

AGI Santo Domingo 2505

No. 110: list of arms expected from Spain, 1773  
No. 111: militia troops' review, 1773  
No. 112: arms and ammunition inventory, 1773  
No. 113: about a bronze cannon  
No. 114: militia troops' review, 1775; arguments justifying the construction of a hospital.  
No. 115: more on what will be needed for the hospital  
No. 116: arms and ammunition inventory, 1774  
No. 117: materials needed for the fortifications  
No. 118: contracts for materials for fortifications

AGI Santo Domingo 2506A

No. 1: regular troops' review, 1776  
No. 2: continuation troops' review, 1776  
No. 3: proposal to enlarge militias  
No. 4: detailed proposal and budget for gunpowder storage building  
No. 5: local limestone supply not reliable  
No. 6: list of arms expected from Spain, 1776  
No. 7: report on fortifications' expenses to 1776. Forced labor engaged in the works.

- No. 8: fort construction report, to 1776
- No. 9: list of arms expected from Spain, 1776
- No. 10: more arms expected from Spain, 1776; fort construction report, January 1776

AGI Santo Domingo 2506B

- No. 11: officers' service records
- No. 12: working code regulating construction of the forts
- No. 13: provision of limestone for the works
- No. 14: wood stolen from the works
- No. 15: more on the stolen wood

AGI Santo Domingo 2507

- No. 20: inventory arms, ammunition, materials, and tools, in royal stores, 1778
- No. 21: regular troops' review, 1778
- No. 22: militia troops' review, 1778
- No. 23: officers' service records
- No. 24: inventory arms and ammunition, 1779; regular troops' review 1779

AGI Santo Domingo 2508

- No. 26: account of fortification expenses, 1779
- No. 27: inventory arms and ammunitions, 1781
- No. 29: list of arms expected from Spain
- No. 30: arms and ammunition inventory, 1783
- No. 31: fortification expenses, 1783
- No. 32: arms and ammunition inventory, 1784; composition of Napoles battalion
- No. 34: troops sent from Spain
- No. 35: troops' review, 1784
- No. 36: troops' review, 1784

AGI Santo Domingo 2509

AGI Santo Domingo 2510

- No. 37: fort construction report, February 1774
- No. 38: Governor Muelas on construction of forts, 1771
- No. 39: correspondence Governor Muelas
- No. 40: expenses of construction, arrival of money from Mexico
- No. 41: report on construction expenses, 1771
- No. 42: fort construction report, April 1772
- No. 43: fort construction report, September 1772
- No. 44: report on construction expenses, 1774
- No. 45: fort construction report, June 1774, May 1775, September 1775
- No. 46: report Governor Dufresne, 1776
- No. 47: fort construction report, January 1775
- No. 48: fort construction report, October 1777
- No. 49: fort construction report, September 1778, January 1779, June 1779
- No. 50: report on construction expenses to 1784

No. 51: report on construction expenses to 1786  
No. 52: inventory arms and ammunition, 1785  
No. 53: inventory arms and ammunition, 1786  
No. 54: continuation of inventory, 1786  
No. 55: protection against lightning bolts

AGI Santo Domingo 2511

San Juan salaried personnel, 1785  
Purchase lightning rod, 1788  
Inventory gunpowder in storage, 1786

AGI Santo Domingo 2512

No. 35: arms and ammunition inventory, 1773  
No. 36: inventory royal warehouse, 1775

AGI Santo Domingo 2522

Pastoral visit Puerto Rican bishop, 1797

AGI Santo Domingo 2523

Political interventions local bishop, 1810  
Other religious administration matters to 1832

AGI Santo Domingo 2525

San Juan cemetery

According to Dr. Altagracia Ortiz (telephone conversation), the following ligatures of the Seville Archives contain documents on Puerto Rico also. No copies of these were available in Boston, San Juan National Historic Site, or at the University of Puerto Rico in Río Piedras.

AGI Santo Domingo 2290-92

Civil and military employees, 1724-1823

AGI Santo Domingo 2293

Saleable offices, 1795-1826

AGI Santo Domingo 2294

Various titles, 1619-1826

AGI Santo Domingo 2344

Hospitals, 1762-1816

AGI Santo Domingo 2345

Acts and letters of the San Juan cabildo, 1769-1850

AGI Santo Domingo 2346  
Acts and letters, 1726-1800

AGI Santo Domingo 2347  
Incoming legal cases, 1776-1846

AGI Santo Domingo 2348-59, 67-78  
Acts, letters, and claims, 1761-1800

AGI Santo Domingo 2385-86  
Duplicates letters and cases, 1644-1772

AGI Santo Domingo 2387-90  
Daily cases, 1760-1799

AGI Santo Domingo 2411  
Government regulations on Royal Treasury, 1716-1832

AGI Santo Domingo 2470-71  
Letters and acts concerning royal officials, 1730-1843

AGI Santo Domingo 2475-80  
Royal Treasury accounts, 1761-86

AGI Santo Domingo 2481  
Royal *cedulas* and accounts, 1693-1795

AGI Santo Domingo 2482  
Accounts royal officials, 1775-1776

AGI Santo Domingo 2483-85  
Royal Treasury Acts, 1774-1809

In addition, the following Archivo General de Indias ligatures contain documents on the history of Puerto Rico, as described by José J. Real Diaz, *Catálogo de las cartas y peticiones del cabildo de San Juan Bautista de Puerto Rico en el Archivo General de Indias (siglos XVI-XVIII)* (San Juan, 1968):

AGI Justicia 976  
Letter Cabildo to King, 1543

AGI Santo Domingo 169  
Letter Cabildo to King, 1699

AGI Santo Domingo 170  
Letter Cabildo to King, 1610



AGI Santo Domingo 174  
Letter Cabildo to King, 1621

AGI Santo Domingo 544  
Letter Cabildo to King, 1706  
Three letters Cabildo to King, 1707

AGI Santo Domingo 551  
Letter Cabildo to King, 1732

AGI Santo Domingo 553  
Letter Cabildo to King, 1720

AGI Santo Domingo 555  
Two letters Cabildo to King, 1733  
Letter Cabildo to King, 1735

AGI Santo Domingo 556  
Letter Cabildo to King, 1681

AGI Santo Domingo 572A  
Letter Cabildo to King, 1735

AGI Santo Domingo 577  
Letter Cabildo to King, 1707

AGI Santo Domingo 2284  
Letter Cabildo to King, 1793

## **B. Archivo Nacional de Cuba, Havana (ANC)**

Copies of documents from this source are arranged in four volumes in the military library, San Juan National Historic Site.

Volume 1 contains:

Index of documents

Royal orders affecting P.R., 1782, 1787, 1797, 1799

English attack, 1797

Miscellaneous documents, 1731, 1765, 1885, 1896, 1898

Félix Prosperí's report on defenses P.R., 1731

Army Regulations for Puerto Rico, 1741; detailed army composition, salaries, uniforms, quarters, hospital

Revision of army regulations, 1782

**C. Archivo General de la Nación, Mexico City (AGN)**

Photocopies of documents from this source are contained in six volumes in the military library, San Juan National Historic Site. Unindexed material, yet each document is properly identified.

Royal *cedulas* or mandates, 1604-1784

*Situado*, economic help sent from Mexico, 1634-1810

Correspondence Viceroy 1782-1816

Printed copy military regulations, 1741

**D. Archivo General de Puerto Rico, San Juan (AGPR)**

AGPR Records of the Spanish Governors

Box 192: Fiscal affairs

Official prices comestibles, 1814

Box 194: Fiscal affairs

Commerce

Box 118: Hospital, printing shop, 1808-1847

Box 227: Military affairs; military regulations 1805

Box 265: Military affairs; prisoners, 1767-1825

Box 240: Military affairs, 1761-1807

Military regulations 1741, as copied from Madrid National Library (Biblioteca Nacional de Madrid), ligature 19,252.

Officers' service records copied from the General Military Archive in Segovia, Spain.

**E. East Florida Papers, P. K. Yonge Library of Florida History, Gainesville, Florida (EF)**

Section 1. Letters from the Captain-General, 1784-1821

Revised to December 1799, bnd. 1A-5E1

Section 2. Letters to the Captain-General, 1784-1821

Revised to December 1799, bnd. 21H2-27A3

Section 4. Secret correspondence to and from the Captain-General, 1787-1813, bnd. 37K3

Section 9. Letters to the Department of the Indies, 1785-1789, bnd. 43D1

Section 10. Letters to and from the Council of the Indies, 1784-1819, bnd. 44E4 and 45F4

Section 11. Letters from the Department of State, 1787-1813, bnd. 46G4

- Section 12. Letters to and from the Department of War, 1790-1812, bnd. 47H4
- Section 14. Correspondence between the Governor of East Florida and the Intendant of Havana, 1784-1821  
Revised to October 1800, bnd. 54B5-56D5
- Section 15. Correspondence between the Governor and *Contador* of East Florida, 1784-1821  
Revised to December 1800, bnd. 66A-71F6
- Section 16. Correspondence between the Governor and Treasurer of East Florida, 1789-1813, bnd. 78
- Section 17. Treasury accounts, 1790-1821  
Revised to December 1810, bnd. 79A7-80B7
- Section 19. Papers of the Accountant of the Royal Hospital of Guadalupe, 1784-1816, bnd. 83E7
- Section 20. Inspections by the *Comisario del Ejercito*, 1789-1821. No bundle number
- Section 32. Correspondence between the Governor and Civil, Financial, and Military Subordinate of the St. Johns and St. Marys Rivers, Matanzas, and other East Florida parts, 1784-1820.  
Revised to January 1789, bnd. 118A10 and 119B10
- Section 35. Letters to and from the garrison commander and other officers, 1784-1821  
Revised to June 1806, bnd. 158B13-160D13
- Section 36. Accounts of the Third Battalion of Cuba, 1789-1800. No bundle number
- Section 37. Letters to and from the Commander of the Artillery Department, 1784-1821  
Revised to September 1802, bnd. 166 and 167K13
- Section 38. Letters to and from the Commander of the Engineering Detachment, 1784-1821. No bundle number
- Section 44. Memorials, 1784-1800, bnd. 176G14-185F15
- Section 45. Papers on various subjects, 1783-1821  
Revised to December 1807, bnd. 277o14

Section 54. Papers on the arrival of vessels and cargoes, 1784-1821  
Revised to December 1791, bnd. 214F17-218J17

Section 61. Proceedings of the Council of War, 1790-1820, bnd. 277o14

Section 62. Proclamations of Edicts, 1786-1821, bnd. 283o13

Section 63. Public contracts, 1788-1820, bnd. 279o12

Section 64. Records of Court Martials, 1785-1821  
Revised to November 1812, bnd. 280

Section 65. Records of criminal proceedings, 1785-1821  
Revised to August 1807, bnd. 283-288



As the nation's principal conservation agency, the Department of the Interior has responsibility for most of our nationally owned public lands and natural and cultural resources. This includes fostering wise use of our land and water resources, protecting our fish and wildlife, preserving the environmental and cultural values of our national parks and historical places, and providing for the enjoyment of life through outdoor recreation. The department assesses our energy and mineral resources and works to ensure that their development is in the best interests of all our people. The department also promotes the goals of the Take Pride in America campaign by encouraging stewardship and citizen responsibility for the public lands and promoting citizen participation in their care. The department also has a major responsibility for American Indian reservation communities and for people who live in island territories under U.S. administration.